

PANEL COMPONENTS

Panel Assembly

HMD914
P/N: 05192

HMD914S
P/N: 05216

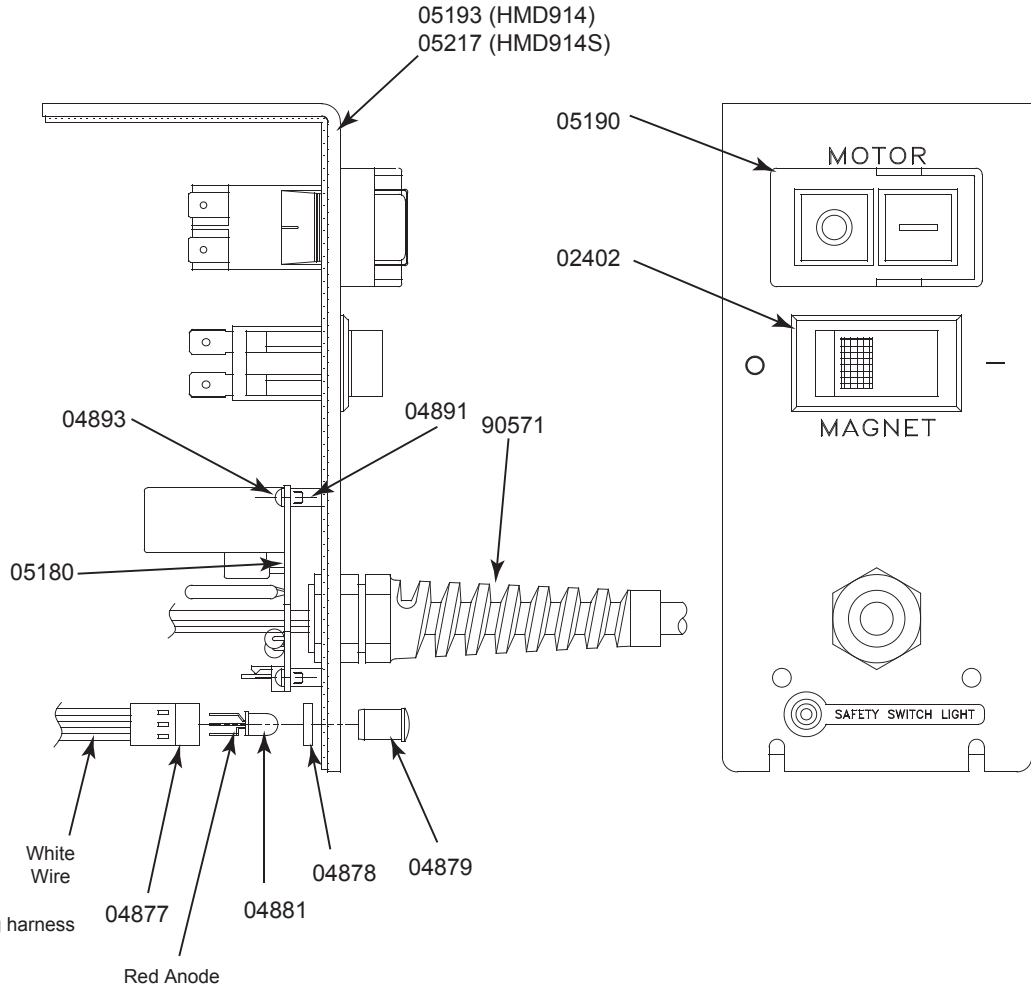

Note: When inserting LED into wiring harness make sure red anode lines up with white wire

Part #	Description	Qty	Part #	Description	Qty
02402	Magnet Switch	1	05180	Circuit Board	1
04877	Wire Harness LED	1	05190	On/Off Switch	1
04878	Spacer LED	1	05193	Faceplate (HMD914)	1
04879	Lens Cover	1	05204*	Wire Harness Jumper	1
04881	LED	1	05207*	Wire Harness Ground	1
04891	Spacer	3	05217	Faceplate (HMD914S)	1
04893	Phillips Screw	3	90571	Power Cord	1
* Not Shown					

HOOK UP DIAGRAM

