

**Hougen®-Ogura™**

**PUNCH PRO™ ELECTRO-HYDRAULIC HOLE PUNCHER**

**OPERATOR'S MANUAL**  
**Model 75002.5**



# IMPORTANT SAFETY INSTRUCTIONS

**WARNING:** When using electric tools, basic safety precautions should always be followed to reduce the risk of fire, electric shock, and personal injury, including the following.

## 1. READ ALL INSTRUCTIONS

### 2. Grounding Instructions

**2a.** This tool should be grounded while in use to protect the operator from electric shock. The tool is equipped with a 3-conductor cord and 3-prong grounding type plug to fit the proper grounding type receptacle. The green (or green and yellow) conductor in the cord is the grounding wire. Never connect the green or green and yellow wire to a live terminal. If your unit is for use on 115V, it has a plug that looks like that shown in sketch (A). If it is for use on 230V, it has a plug that looks like that shown in sketch (D). An adapter, see sketches (B) and (C), is available for connecting sketch (A) type plugs to 2-prong receptacles. The green-colored rigid ear, lug, or the like extending from the adapter must be connected to a permanent ground, such as a properly grounded outlet box. No adapter is available for a plug as shown in sketch (D).

**NOTE: Use of a grounding adapter is prohibited in Canada by Part 1 of the Canadian Electrical Code.**

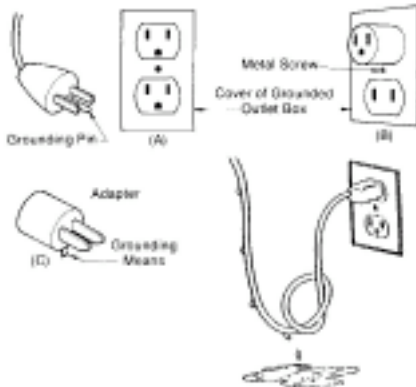

### 2b. Extension Cords

Use only 3-wire extension cords that have 3-prong grounding type plugs and 3-pole receptacles that accept the tool's plug. Replace or repair damaged cords. Make sure the conductor size is large enough to prevent excessive voltage drop will cause loss of power and possible motor damage

## 3. FOR ALL DOUBLE-INSULATED TOOLS

When servicing use only identical replacement parts.

## 4. Keep Work Area Clean

Cluttered areas and benches invite injuries.

## 5. Consider Work Area Environment

Do not expose tool to rain  
Do not use tool in damp or wet locations. Keep work area well lit.  
Do not use tool in presence of flammable liquids or gases.

## 6. Guard Against Electric Shock

Prevent body contact with grounded surfaces. For example: pipes, radiators, ranges, refrigerator enclosures.

## 7. Keep Children Away

Do not let visitors contact tool or extension cord. All visitors should be kept away from work area.

## 8. Store Idle Tools

When not in use, tools should be stored in a dry high or locked-up place-out of reach of children.

## 9. Do Not Force Tool

It will do the job better and safer at the rate for which it was intended.

## 10. Use Right Tool

Do not force small tool or attachment to do the job of a heavy-duty tool. Do not use tool for purpose not intended.

## 11. Dress Properly

Do not wear loose clothing or jewelry. They can be caught in moving parts. Rubber gloves and non skid footwear are recommended when working outdoors. Wear protective hair covering to contain long hair.

## 12. Always wear safety glasses or goggles.

## 13. Do Not Abuse Cord.

Never carry tool by cord or yank it to disconnect from receptacle. Keep cord from heat, oil and sharp edges.

# PRINCIPLES OF OPERATION

The Hougén-Ogura Electro-hydraulic Hole Puncher is an integrated unit, containing the electric motor, hydraulic pump, and "C"-frame punching unit. It uses hydraulic power to force the punch through the workpiece, and a strong spring to return the punch piston to its "home" position. The patented design includes an automatic valve that releases the hydraulic pressure when the punch piston is at the bottom of its stroke. The automatic valve remains open until the punch piston has fully returned to the home position.

As a result of this design, the piston will not return to its home position automatically unless the full stroke has been completed. Also, the punch will not begin another stroke unless the punch has fully returned to the home position, resetting the automatic valve. To allow the punch piston to be manually returned in the event that the punch cycle is stopped prior to completion, a manual return valve is provided. (See Item #15 on the parts breakdown.)

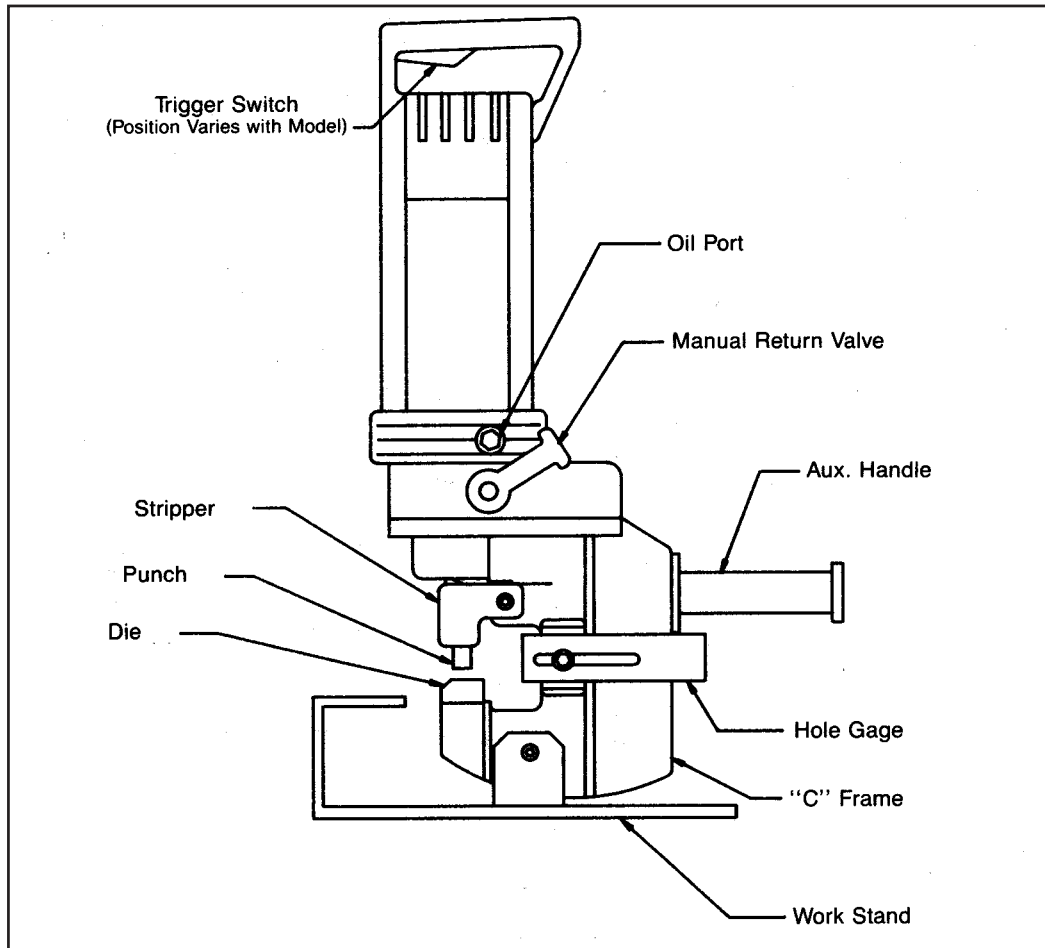

## HOLE LOCATOR GAGE ADJUSTMENT

The Hole locator Gage (6) can be set to hold the Hole Punches at a constant distance from the edge of the workpiece. The gage is held in place by one or two socket head caps screws. Before making any adjustment,

first, unplug the power cord. To adjust the position of the gage, loosen the cap screw(s), tap the gage into the desired position and re-tighten the cap screw(s).

## USING THE WORK STAND

All models can be used with an accessory work stand for bench or table mounting of the Hole Puncher. The stand is standard with all models. To install the stand, first unplug the power cord., then mount the unit to the stand with the supplied hardware.

When using the stand, periodically check to make sure that the punched material (slugs) are not stacking up between the exit hole in the "C"-frame and the stand. Keep this area clear of accumulated slugs.

# OPERATING PROCEDURES

Read, understand and follow all safety instructions and operating procedures. If you do not understand the instructions or if conditions are not correct for proper operation, do not operate the machine. Consult your supervisor or other responsible person.

\*Check that the trigger switch (33-5) is not locked on.

\*Check that the manual return valve (15) is closed.

\*Make sure that the proper punch and die are installed correctly. See **Die Selection** and **Proper Punches and Dies** in this Manual

\*If you are using the hole locator gage (6), adjust it to the proper distance. See **Hole Locator Gage Adjustment** in this manual.

\*Plug the power cord into the proper power supply.

\*Position the puncher at the proper location on the workpiece using the hole locator gage or by locating the point on the end of the punch into a center punch mark on the piece.

With everything in proper order, the switch can be activated to start the electric motor. The punch piston will move out and push the punch through the material. Keep the switch on until the punch has reached the end of its stroke and stops. Release the switch. The automatic return valve will open at the end of the stroke allowing the punch piston to retract to its home position. The punch piston must return completely before another hole can be punched.

If the punch stops in the midst of its stroke or does not come out of the material, open the manual return valve (15). Once the punch piston has returned to its home position, tighten the manual return valve.

## INSTRUCTIONS -- FOOT SWITCH

Although the foot switch is guarded against inadvertent operation, it is best to position the foot pedal away from normal standing position. Place it in a position that requires deliberate effort to reach and activate the switch.

The trigger switch should be locked on only when ready to punch. Release the trigger switch immediately after punching to prevent operation by inadvertent actuation of the foot switch.

## HELPFUL HINTS FOR HOLE PUNCHING

Each of the punches is provided with a sharp point at its center. If the hole locations are center punched, the point on the end of the punch may be used to "find" the center punched spot.

Also, for accurate and easy positioning of the punch to a hole location, the switch can be intermittently pulsed on and off to jog the punch down to the work surface.

If the position is not satisfactory, open the manual return valve to retract the punch for another attempt. This operation can also be performed with the manual return valve "cracked" open slightly to prevent full punching pressure from being developed. In this manner, the punch can be easily brought right down to the surface without beginning to punch the hole. If the location is satisfactory, close the valve and finish the operation.

# NEW AND IMPROVED PUNCH RETAINING

## New Quick Change Punch

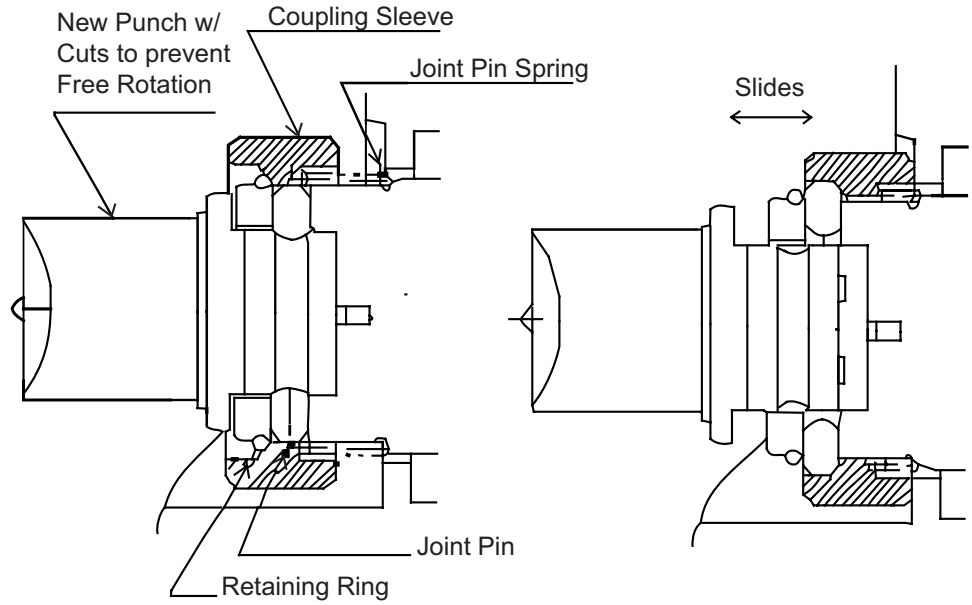

## Old Style Punch and Retaining Nut

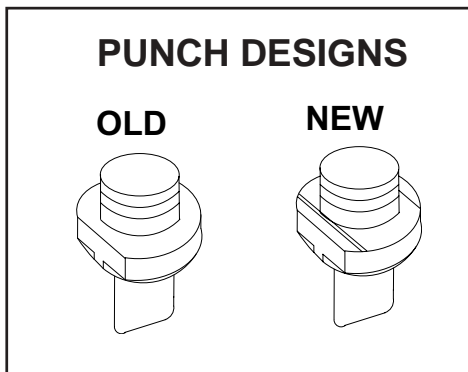
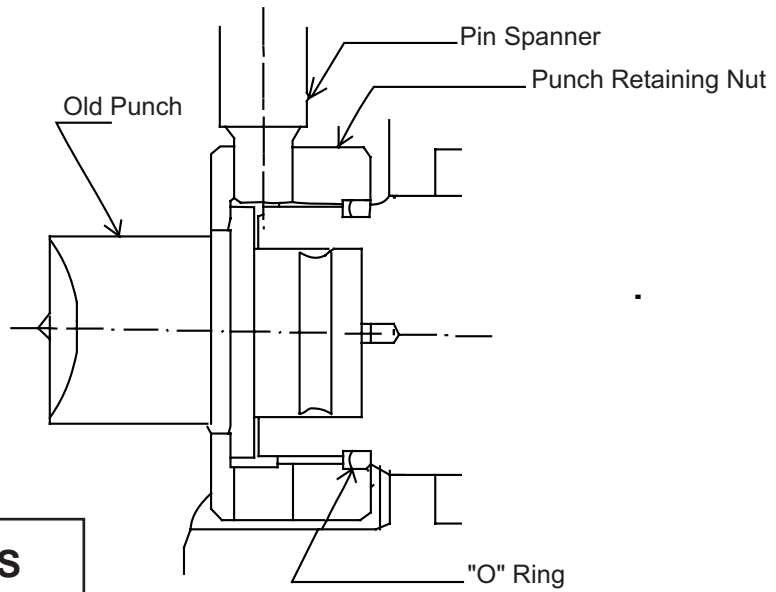

# MAINTENANCE

In order to insure smoother operation and longer life of your hole puncher, the following maintenance should be done periodically, based on use.

1. Keep the machine clean. It is especially important to keep the sliding portion of the punch piston free from metal chips, scale, dirt, dust or other debris. To clean the punch piston, turn on the switch to move the punch piston almost to the bottom of its stroke. If necessary, cycle the punch several times to determine where the bottom of the stroke is, and to correctly position the punch piston.

Unplug the power cord. Wipe any debris from the exposed part of the punch piston.

2. Regularly tighten all fasteners and replace any worn components.
3. Check power cord, if cracked or frayed, return the machine to an authorized repair center for replacement.
4. Check oil level, carefully using the procedure below.

# ADDING OIL

Use of the correct hydraulic oil is essential. Approved oils are Shell "TELLUS Oil" and Exxon "TERESSTIC". Depending on the hole puncher model, either #32 or #46 viscosity must be used. Check the unit specifications. Make sure that the work area and all equipment are clean so that no dirt, dust or other foreign material can get into the hydraulic oil or pump area.

1. Locate the socket head cap screw (60) that plugs the oil port. It is just above the manual return lever on the right hand side of the Hole Puncher.
2. Lay the Hole Puncher on its left side so that the oil port is facing up.
3. Turn on the switch to move the punch piston almost to the bottom of its stroke. If necessary, cycle the punch several times to determine where the bottom of the stroke is, and to correctly position the punch piston. In this position, the maximum amount of oil has been drawn from the pump and the correct fill can be obtained.

4. Carefully open the oil port by removing the socket head cap screw (60).

5. Using the small squeeze bottle supplied with the Hole Puncher, carefully add hydraulic oil to completely fill the reservoir. Rock the Hole Puncher back and forth slightly several times to free any trapped air bubbles, then add additional oil if necessary.

6. Replace the cap screw and wipe up any excess oil.

7. Cycle the Hole Puncher several times with the Manual return Valve open, and again with the valve closed, to work any trapped air out of the system, then repeat the above procedure, making sure that the punch piston is almost at the bottom of the stroke before removing the cap screw from the oil port.

8. Add additional oil as necessary. If the unit was extremely low on oil, it may be necessary to repeat the procedure several times.

# SELECTING PROPER DIES

Proper die selection is essential. Other than the obvious necessity of matching shaped punches and dies, there are two other basic selection factors that must be considered. The first is die clearance. Different material types and different material thicknesses require different clearances between the punch and die. In order to maintain the best possible hole while remaining within the tonnage capacity of the machine, it is essential to choose the die with the proper clearance. The second is the die angle. Most structural shapes can be punched with the standard

flat dies, but "I" -beams and most channels which have a 2-in-12 taper require the use of special 9-1/2 degree angled dies. Car and ship channel flanges and other structural shapes with a 2 degree taper can be punched with flat dies. Materials with a flange taper of less than 5 degrees can also be punched with the flat die, however, the hole will be slightly angled. Refer to specific information and tables within this manual for the proper punch and die combination.

## Extension Cord Selection

		LENGTH OF CORD IN FEET									
		115V	25 FT.	50 FT.	100 FT.	150 FT.	200 FT.	250 FT.	300 FT.	400 FT.	500FT
		230V	50 FT.	100 FT.	200 FT.	300 FT.	400 FT.	500 FT.	600 FT.	800 FT.	1000 FT
Nameplate Ampere rating	0-2	18	18	18	16	16	14	14	12	12	
	2-3	18	18	16	14	14	12	12	10	10	
	3-4	18	18	16	14	12	12	10	10	8	
	4-5	18	18	14	12	12	10	10	8	8	
	5-6	18	16	14	12	10	10	8	8	8	
	6-8	18	16	12	10	10	8	6	6	6	
	8-10	18	14	12	10	8	8	6	6	4	
	10-12	16	14	10	8	8	6	6	4	4	
	12-14	16	12	10	8	6	6	6	4	2	
	14-16	16	12	10	8	6	6	4	4	2	
	16-18	14	12	8	8	6	4	4	2	2	
	18-20	14	12	8	6	6	4	4	2	2	

**NOTE:** The internal components of the pump and piston area have very close clearances and are sensitive to damage from dust, dirt, contamination of the hydraulic fluid or improper handling. The disassembly of the pump housing requires special tools and training, and should be attempted by a qualified repair person. The improper servicing of electrical components can lead to conditions that could cause serious injury.

**ANY ATTEMPT BY UNAUTHORIZED PERSONNEL TO SERVICE THE INTERNAL COMPONENTS OF THE PUMP AREA WILL VOID THE WARRANTY.**

# 75002.5 EXPLODED VIEW

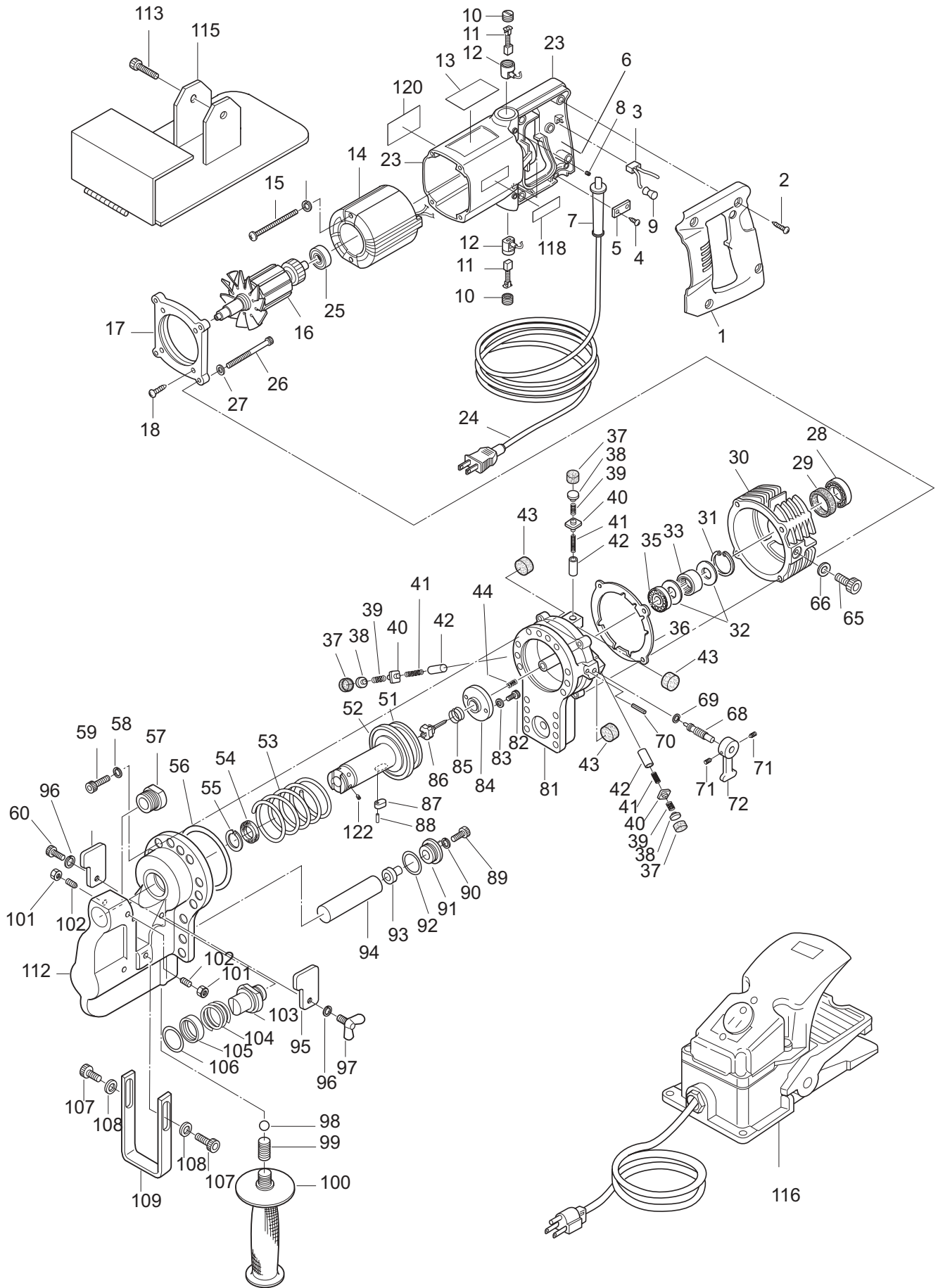

# PARTS LIST - 75002.5

Detail No.	Description	Part No.	No. Req'd.	Detail No.	Description	Part No.	No. Req'd.
1	SCR-PAN HD SELF TAP	75232	4	55	BACK UP RING	75152	1
2	SWITCH COVER	75225	1	56	O-RING	75185	1
3	FILTER CAPACITOR	75239	1	57	DIE-RD 9/16A	75444	1
4	SCR-PAN HD SELF TAP	75245	2		DIE-RD 9/16B	75445	1
5	CORD RETAINER	75244	1	58	WASHER-FLAT	75159	18
6	TRIGGER SWITCH	75143	1	59	SCR-SHC M8 x 20MM	75158	18
7	STRAIN RELIEF	75074	1	60	SCR-SHC M6 x 15MM	75156	1
8	SCR-SOC SET	75246	1	65	SCR-SHC M10 x 15MM	75107	1
9	WIRE CONNECTOR	75113	1	66	SEAL WASHER	75090	1
10	BRUSH CAP	75229	2	68	RETURN VALVE	75046	1
11	CARBON BRUSH PAIR	75228	2	69	O-RING	75085	1
12	BRUSH HOLDER	75227	2	70	WASHER FLAT	75100	1
13	NAME TAG	75168	1	71	SCR-SET M6 x 8MM	75160	1
14	FIELD	75223	1	72	RETURN LEVER	75047	1
15	SCR-PAN HD PHILLIPS	75231	2	81	CYLINDER	75174	1
16	ARMATURE	75224	1	82	SCR-SHC M4 x 6MM	75102	2
17	SUB PLATE	75169	1	83	WASHER FLAT	75101	2
18	SCR-PAN HD SELF TAP	75237	4	84	STOP PLATE	75183	1
23	MOTOR HOUSING	75222	1	85	VALVE RETURN SPRING	75043	1
24	POWER CORD	75230	1	86	RELEASE VALVE	75042	1
25	BALL BEARING	75170	1	87	PUNCH PISTON KEY	75135	1
26	SCR-SHC M5 x 65MM	75171	4	88	ROLL PIN	75099	1
27	WASHER-HELI LOCK	75150	4	89	SCR-BLADDER RET.	75138	1
28	BALL BEARING	75087	1	90	WASHER-HELI LOCK	75155	1
29	OIL SEAL	75084	1	91	SCR-BLADDER BUSHING	75188	1
30	PUMP HOUSING	75172	1	92	O-RING	75190	1
31	RETAINING RING	75089	1	93	SCR-BLADDER	75136	1
32	SPACER	75055	2	94	OIL BLADDER	75137	1
33	ROLLER BEARING	75088	1	95	STRIPPER	75131	1
35	BALL BEARING	75086	1	96	WASHER-HELI LOCK	75162	2
36	GASKET	75173	1	97	SCR-WING HD	75175	1
37	SEAL-PACKING	75049	3	98	STEEL BALL BEARING	75191	1
38	SPRING RETAINER	75051	3	99	SCR-SOC SET M10	75192	1
39	CHECK VALVE SPRING	75052	3	100	PUNCHER HANDLE	75063	1
40	CHECK VALVE	75050	3	101	NUT-HEX M6	75091	2
41	PISTON RETURN SPRING	75053	3	102	SCR-SOC SET M6	75189	2
42	PUMP PISTON	75048-A	1-3	103	SCR-PAN HD PHILLIPS	75427	1
	PUMP PISTON	75048-B	1-3	104	JOINT PIN SPRING	75116	1
	PUMP PISTON	75048-C	1-3	105	COUPLING SLEEVE	75115	1
	PUMP PISTON	75048-D	1-3	106	RING RETAINING	75117	1
	PUMP PISTON	75048-E	1-3	107	SCR-SHC M6	75156	2
	PUMP PISTON	75048-F	1-3	108	WASHER FLAT 6MM	75157	2
	PUMP PISTON	75048-G	1-3	109	HOLE LOCATOR	75176	1
	PUMP PISTON	75048-H	1-3	112	C-FRAME	75177	1
	PUMP ,PISTON	75048-I	1-3	113	SCR-SHC M6	75156	1
	PUMP PISTON	75048-J	1-3	115	WORK STAND	75166	1
43	MAGNET	75054	3	116	FOOT SWITCH	75110	1
44	VALVE RELEASE SPRING	75184	1	118	CAUTION TAG	75034	1
51	PACKING	75154	1	120	WARNING TAG	75033	1
52	PUNCH PISTON	75118	1	122	JOINT SPRING	75114	6
53	PUNCH RETURN SPRING	75187	1				
54	PACKING ROD SEAL	75153	1				

# ROUND PUNCHES AND DIES FOR 75002.5

ROUND PUNCHES			MATERIAL		DIE		
SIZE			PART NO.	THICKNESS	STYLE	SIZE	PART NO.
NOMINAL	ACTUAL	METRIC					
1/4"	(.256)	6.5MM	75421	5/64 (.078) TO 1/8" (.125) 14 TO 11 GAGE	F,A,H	DIE LD 1/4 A	75454
				>1/8 (.125) TO 1/4 (.250) 10 TO 3 GAGE	F,A,H	DIE LD 1/4 B	75455
5/16"	(.315)	8MM	75422	5/64 (.078) TO 1/8" (.125) 14 TO 11 GAGE	F,A,H	DIE LD 5/16 A	75456
				>1/8 (.125) TO 1/4 (.250) 10 TO 3 GAGE	F,A,H	DIE LD 5/16 B	75457
11/32"	(.335)	8.5MM	75423	5/64 (.078) TO 1/8" (.125) 14 TO 11 GAGE	F,A,H	DIE LD 11/32 A	75458
				>1/8 (.125) TO 1/4 (.250) 10 TO 3 GAGE	F,A,H	DIE LD 11/32 B	75459
3/8"	(.394)	10MM	75424	5/64 (.078) TO 1/8" (.125) 14 TO 11 GAGE	F,A,H	DIE LD 3/8 A	75460
				>1/8 (.125) TO 1/4 (.250) 10 TO 3 GAGE	F,A,H	DIE LD 3/8 B	75461
			75476 (LP)	5/64 (.078) TO 1/8" (.125) 14 TO 11 GAGE	F,A,H	DIE 3/8 A	75438
				>1/8 (.125) TO 1/4 (.250) 10 TO 3 GAGE	F,A,H	DIE 3/8 B	75439
		19/64 (.297) MAX.	C	DIE 3/8 C	75450		
7/16"	(.433)	11MM	75425	5/64 (.078) TO 1/8" (.125) 14 TO 11 GAGE	F,A,H	DIE LD 7/16 A	75462
				>1/8 (.125) TO 1/4 (.250) 10 TO 3 GAGE	F,A,H	DIE LD 7/16 B	75463
			75477 (LP)	5/64 (.078) TO 1/8" (.125) 14 TO 11 GAGE	F,A,H	DIE 7/16 A	75440
				>1/8 (.125) TO 1/4 (.250) 10 TO 3 GAGE	F,A,H	DIE 7/16 B	75441
		19/64 (.297) MAX.	C	DIE 7/16 C	75451		
1/2"	(.512)	13MM	75426	5/64 (.078) TO 1/8" (.125) 14 TO 11 GAGE	F,A,H	DIE LD 1/2 A	75464
				>1/8 (.125) TO 1/4 (.250) 10 TO 3 GAGE	F,A,H	DIE LD 1/2 B	75465
			75478 (LP)	5/64 (.078) TO 1/8" (.125) 14 TO 11 GAGE	F,A,H	DIE 1/2 A	75442
				>1/8 (.125) TO 1/4 (.250) 10 TO 3 GAGE	F,A,H	DIE 1/2 B	75443
		19/64 (.297) MAX.	C	DIE 1/2 C	75452		
9/16"	(.551)	14MM	75427	5/64 (.078) TO 1/8" (.125) 14 TO 11 GAGE	F,A,H	DIE LD 9/16 A	75466
				>1/8 (.125) TO 1/4 (.250) 10 TO 3 GAGE	F,A,H	DIE LD 9/16 B	75467
			75479 (LP)	5/64 (.078) TO 1/8" (.125) 14 TO 11 GAGE	F,A,H	DIE 9/16 A	75444
				>1/8 (.125) TO 1/4 (.250) 10 TO 3 GAGE	F,A,H	DIE 9/16 B	75445
		19/64 (.297) MAX.	C	DIE 9/16 C	75453		
5/8"	(.625)	15.9MM	75428	5/64 (.078) TO 1/8" (.125) 14 TO 11 GAGE	F,A,H	DIE LD 5/8 A	75468
				>1/8 (.125) TO 1/4 (.250) 10 TO 3 GAGE	F,A,H	DIE LD 5/8 B	75469
11/16"	(.688)	17.5MM	75429	5/64 (.078) TO 1/8" (.125) 14 TO 11 GAGE	F,A,H	DIE LD 11/16 A	75470
				>1/8 (.125) TO 1/4 (.250) 10 TO 3 GAGE	F,A,H	DIE LD 11/16 B	75471
3/4"	(.750)	19MM	75430	5/64 (.078) TO 1/8" (.125) 14 TO 11 GAGE	F,A,H	DIE LD 3/4 A	75472
				>1/8 (.125) TO 1/4 (.250) 10 TO 3 GAGE	F,A,H	DIE LD 3/4 B	75473
25/32"	(.787)	20MM	75431	5/64 (.078) TO 1/8" (.125) 14 TO 11 GAGE	F,A,H	DIE LD 25/32 A	75474
				>1/8 (.125) TO 1/4 (.250) 10 TO 3 GAGE	F,A,H	DIE LD 25/32 B	75475

## OBLONG PUNCHES AND DIES FOR 75002.5

OBLONG PUNCH			MATERIAL		DIE		
SIZE			PART NO.	THICKNESS	STYLE	SIZE	PART NO.
NOMINAL	ACTUAL	METRIC					
1/4" X 1/2"	.256 X .512	6.5MM X 13MM	75638	5/64 (.078) TO 1/8 (.125) 14 TO 11 GA	F,A,H	DIE LD 1/4+ X 1/2 A	75656
				>1/8 (.125) TO 1/4 (.250) 10 TO 3 GA.	F,A,H	DIE LD 1/4+ X 1/2 B	75657
			75666 (LP)	5/64 (.078) TO 1/8 (.125) 14 TO 11 GA	F,A,H	DIE 1/4+ X 1/2 A	75643
				>1/8 (.125) TO 1/4 (.250) 10 TO 3 GA.	F,A,H	DIE 1/4+ X 1/2 B	75644
			19/64 ((.297))	C	DIE 1/4+ X 1/2 C	75653	
11/32" X 1/2"	.335 X .512	8.5MM X 13MM	75639	5/64 (.078) TO 1/8 (.125) 14 TO 11 GA	F,A,H	DIE LD 11/32 X 1/2 A	75658
				>1/8 (.125) TO 1/4 (.250) 10 TO 3 GA.	F,A,H	DIE LD 11/32 X 1/2 B	75659
			75667 (LP)	5/64 (.078) TO 1/8 (.125) 14 TO 11 GA	F,A,H	DIE 11/32 X 1/2 A	75645
				>1/8 (.125) TO 1/4 (.250) 10 TO 3 GA.	F,A,H	DIE 11/32 X 1/2 B	75646
			19/64 ((.297))	C	DIE 11/32 X 1/2C	75654	
7/16" X 5/8"	.433 X .650	11MM X 16.5MM	75640	5/64 (.078) TO 1/8 (.125) 14 TO 11 GA	F,A,H	DIE LD 7/16 X 5/8 A	75660
				>1/8 (.125) TO 1/4 (.250) 10 TO 3 GA.	F,A,H	DIE LD 7/16 X 5/8 B	75661
			75668 (LP)	5/64 (.078) TO 1/8 (.125) 14 TO 11 GA	F,A,H	DIE 7/16 X 5/8 A	75647
				>1/8 (.125) TO 1/4 (.250) 10 TO 3 GA.	F,A,H	DIE 7/16 X 5/8 B	75648
			19/64 ((.297))	C	DIE 7/16 X 5/8 C	75655	
1/2+ " X 3/4"	.512 X .768	13MM X 19.5MM	75641	5/64 (.078) TO 1/8 (.125) 14 TO 11 GA	F,A,H	DIE LD 1/2+ X 3/4 A	75662
				>1/8 (.125) TO 1/4 (.250) 10 TO 3 GA.	F,A,H	DIE LD 1/2+ X 3/4 B	75663
9/16" X 13/16"	.551 X .827	14MM X 21MM	75642	5/64 (.078) TO 1/8 (.125) 14 TO 11 GA	F,A,H	DIE LD 9/16 X 13/16 A	75664
				>1/8 (.125) TO 1/4 (.250) 10 TO 3 GA.	F,A,H	DIE LD 9/16 X 13/16 B	75665

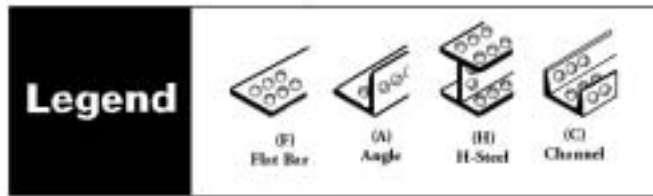

## SQUARE PUNCHES AND DIES FOR 75002.5

SQUARE PUNCH			MATERIAL		DIE		
SIZE			PART NO.	THICKNESS	STYLE	SIZE	PART NO.
NOMINAL	ACTUAL	METRIC					
1/4"	(.256)	6.5mm	75800	>1/8 (.125) to 1/4 (.250) 10 to 3 Ga.	F,A,H	Die 1/4 B	75804
5/16"	(.315)	8mm	75801	>1/8 (.125) to 1/4 (.250) 10 to 3 Ga.	F,A,H	Die 5/16 B	75805
3/8"	(.394)	10mm	75802	>1/8 (.125) to 1/4 (.250) 10 to 3 Ga.	F,A,H	Die 3/8 B	75806
7/16"	(.433)	11mm	75803	>1/8 (.125) to 1/4 (.250) 10 to 3 Ga.	F,A,H	Die 7/16 B	75807

## Commercial / Industrial Limited Warranty

Hougen Manufacturing, Incorporated warrants its Portable Magnetic Drills, Electro-hydraulic Hole Punchers for a period of (1) one year and other products for ninety (90) days from date of purchase against defects due to faulty material or workmanship and will repair or replace (at its option) without charge any items returned. This warranty is void if the item has been damaged by accident or unreasonable use, neglect, improper service, or other causes not arising out of defects in material or workmanship. No other expressed warranty is given or authorized. Hougen Manufacturing, Inc. disclaims any implied warranty of MERCHANTABILITY or FITNESS for any period beyond the expressed warranty and shall not be liable for incidental or consequential damages. Some states do not allow exclusions of incidental or consequential damages or limitation on how long an implied warranty lasts and, if the law of such a state governs your purchase, the above exclusion and limitation may not apply to you. This warranty gives you specific legal rights and you may also have other rights which vary from state to state.

To obtain warranty service, return the item(s), transportation prepaid, to your nearest Factory Authorized Repair Center or to Hougen Manufacturing, Inc., 3001 Hougen Drive, Swartz Creek, Michigan 48473.

Hougen Drills (Rotabroach Cutters) are warranted against manufacturing defects only. Subject to Hougen Manufacturing inspection.

THIS WARRANTY IS IN LIEU OF ANY OTHER WARRANTY, EXPRESSED OR IMPLIED, INCLUDING ANY WARRANTY OF MERCHANTABILITY OR FITNESS FOR A PARTICULAR PURPOSE

© 2003 Hougen Manufacturing, Inc.

## Hougen-Ogura Patent Notice

Photographs and Specifications shown are accurate in detail at time of printing. Manufacture reserves the right to make improvements and modifications without prior notice.

Hougen, Hougen-Edge, Rotabroach, Punch-Pro, Trak-Star and the Hougen logo are proprietary trademarks of Hougen Manufacturing, Inc. Ogura and Ogura logo are proprietary trademarks of Ogura & Co., Ltd.

**Factory Warranty Repair Services** can be obtained by sending your product to:

Hougen Manufacturing, Inc.  
3001 Hougen Drive  
Swartz Creek, MI 48473  
Attn: Repair Department

*Hougen-Ogura™*

Hougen Manufacturing, Inc.

P.O. Box 2005 Flint, Mi. 48501-2005

3001 Hougen Drive • Swartz Creek, Mi. 48473

Phone (810) 635-7111 Fax (810) 635-8277