

Hougen[®]-**Ogura**[™]

PUNCH PRO[™] ELECTRO-HYDRAULIC HOLE PUNCHER

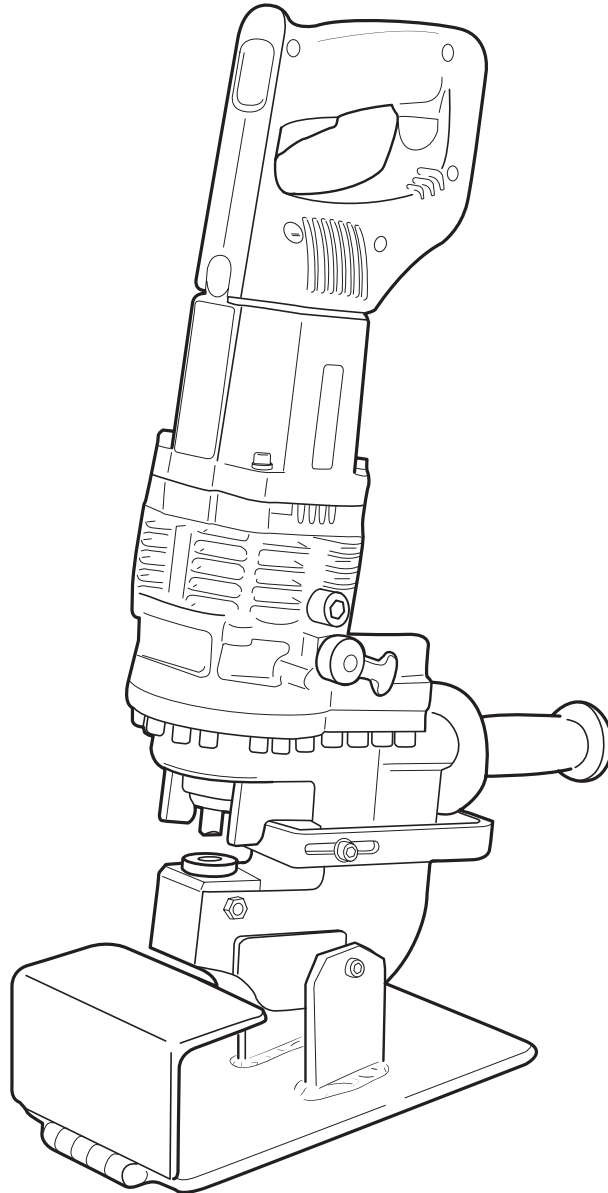

**OPERATOR'S MANUAL
Model 75002.5A**

IMPORTANT SAFETY INSTRUCTIONS

WARNING: When using electric tools, basic safety precautions should always be followed to reduce the risk of fire, electric shock, and personal injury, including the following.

1. READ ALL INSTRUCTIONS

2. Grounding Instructions

2a. This tool should be grounded while in use to protect the operator from electric shock. The tool is equipped with a 3-conductor cord and 3-prong grounding type plug to fit the proper grounding type receptacle. The green (or green and yellow) conductor in the cord is the grounding wire. Never connect the green or green and yellow wire to a live terminal. If your unit is for use on 115V, it has a plug that looks like that shown in sketch (A). An adapter, see sketches (B) and (C), is available for connecting sketch (A) type plugs to 2-prong receptacles. The green-colored rigid ear, lug, or the like extending from the adapter must be connected to a permanent ground, such as a properly grounded outlet box.

NOTE: Use of a grounding adapter is prohibited in Canada by Part 1 of the Canadian Electrical Code.

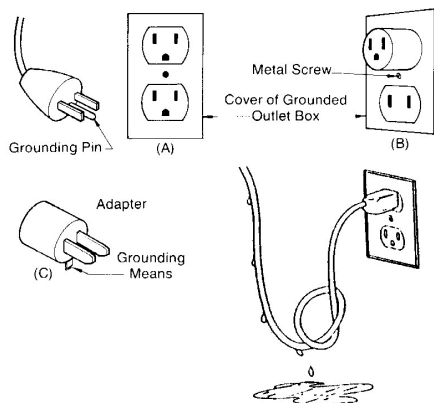

2b. Extension Cords

Use only 3-wire extension cords that have 3-prong grounding type plugs and 3-pole receptacles that accept the tool's plug. Replace or repair damaged cords. Make sure the conductor size is large enough to prevent excessive voltage drop causing loss of power and possible motor damage

3. FOR ALL DOUBLE-INSULATED TOOLS

When servicing use only identical replacement parts.

4. Keep Work Area Clean

Cluttered areas and benches invite injuries.

5. Consider Work Area Environment

Do not expose tool to rain
Do not use tool in damp or wet locations. Keep work area well lit.
Do not use tool in presence of flammable liquids or gases.

6. Guard Against Electric Shock

Prevent body contact with grounded surfaces. For example: pipes, radiators, ranges, refrigerator enclosures.

7. Keep Children Away

Do not let visitors contact tool or extension cord. All visitors should be kept away from work area.

8. Store Idle Tools

When not in use, tools should be stored in a dry high or locked-up place-out of reach of children.

9. Do Not Force Tool

It will do the job better and safer at the rate for which it was intended.

10. Use Right Tool

Do not force small tool or attachment to do the job of a heavy-duty tool. Do not use tool for purpose not intended.

11. Dress Properly

Do not wear loose clothing or jewelry. They can be caught in moving parts. Rubber gloves and non skid footwear are recommended when working outdoors. Wear protective hair covering to contain long hair.

12. Always wear safety glasses or goggles.

13. Do Not Abuse Cord.

Never carry tool by cord or yank it to disconnect from receptacle. Keep cord from heat, oil and sharp edges.

LENGTH OF CORD IN FEET							
115V (Amps)	25 FT.	50 FT.	100 FT.	150 FT.	200 FT.	250 FT.	300 FT.
5-6	18	16	14	12	10	10	8
6-8	18	16	12	10	10	8	6
8-10	18	14	12	10	8	8	6
10-12	16	14	10	8	8	6	6
12-14	16	12	10	8	6	6	6
14-16	16	12	10	8	6	6	4

SAFETY FIRST

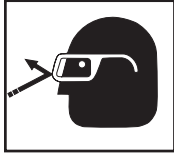

Always wear eye protection while using punching tools, or in the vicinity of punching.



CAUTION! Risk of pinching or crushing. Keep away from moving parts when unit is in use.



CAUTION! The slug is ejected at the end of the punch. Do not aim the unit so that ejected slug may hit someone around, or below you.



CAUTION! To prevent electric shock, do not use power tools near wet areas, or where power tool may become wet.

PRINCIPLES OF OPERATION

The Hougen-Ogura Electro-hydraulic Hole Puncher is an integrated unit, containing the electric motor, hydraulic pump, and "C"-frame punching unit. It uses hydraulic power to force the punch through the workpiece, and a strong spring to return the punch piston to its "home" position. The patented design includes an automatic valve that releases the hydraulic pressure when the punch piston is at the bottom of its stroke. The automatic valve remains open until the punch piston has fully returned to the home position.

As a result of this design, the piston will not return to its home position automatically unless the full stroke has been completed. Also, the punch will not begin another stroke unless the punch has fully returned to the home position, resetting the automatic valve. To allow the punch piston to be manually returned in the event that the punch cycle is stopped prior to completion, a manual return valve is provided.

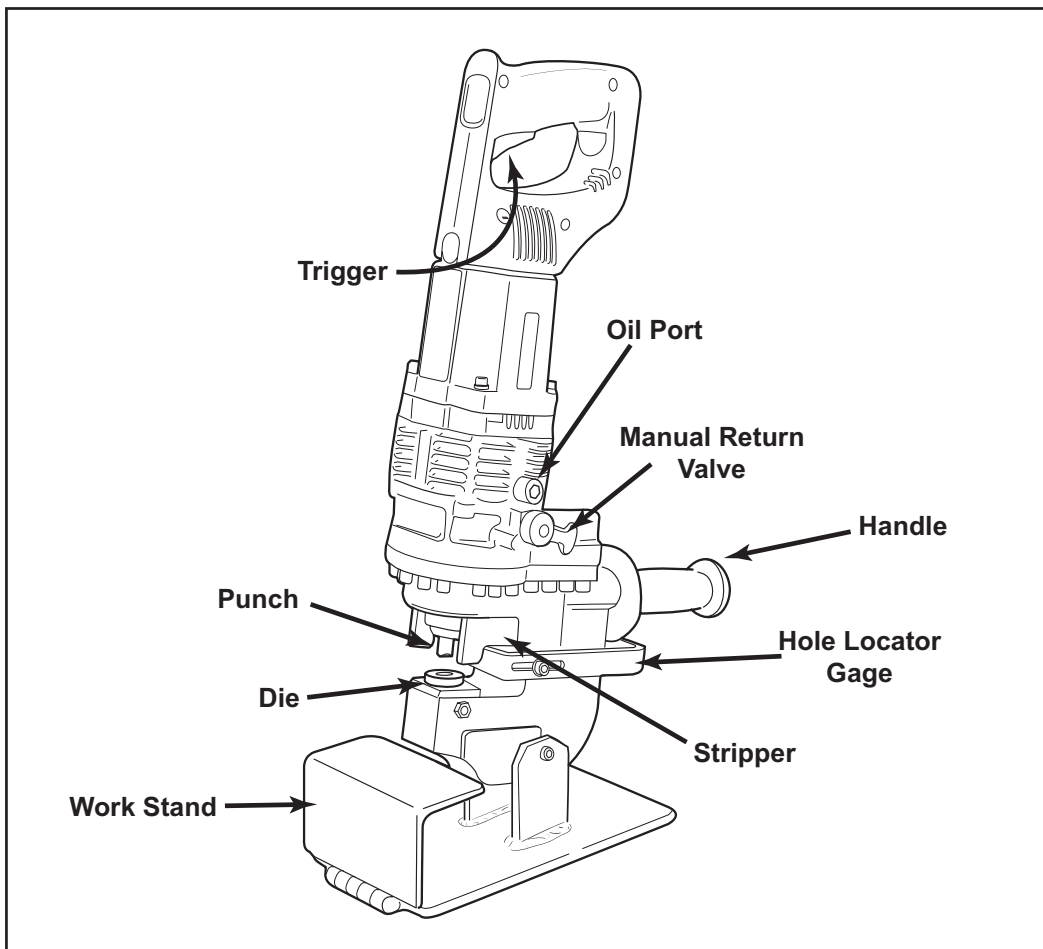

OPERATING PROCEDURES

Read, understand and follow all safety instructions and operating procedures. If you do not understand the instructions or if conditions are not correct for proper operation, do not operate the machine. Consult your supervisor or other responsible person.

*Check that the trigger switch is not locked on.

*Check that the manual return valve is closed.

*Make sure that the proper punch and die are installed correctly. See **Die Selection** and **Proper Punches and Dies** below.

*If you are using the hole locator gage, adjust it to the proper distance. See **Hole Locator Gage Adjustment** below.

*Plug the power cord into the proper power supply.

*Position the puncher at the proper location on the workpiece using the hole locator gage or by locating the point on the end of the punch into a center punch mark on the piece.

With everything in proper order, the switch can be activated to start the electric motor. The punch piston will move out and push the punch through the material. Keep the switch on until the punch has reached the end of its stroke and stops. Release the switch. The automatic return valve will open at the end of the stroke allowing the punch piston to retract to its home position. The punch piston must return completely before another hole can be punched.

If the punch stops in the midst of its stroke or does not come out of the material, open the manual return valve. Once the punch piston has returned to its home position, tighten the manual return valve.

INSTRUCTIONS -- FOOT SWITCH

Although the foot switch is guarded against inadvertent operation, it is best to position the foot pedal away from normal standing position. Place it in a position that requires deliberate effort to reach and activate the switch.

The trigger switch should be locked on only when ready to punch. Release the trigger switch immediately after punching to prevent operation by inadvertent actuation of the foot switch.

HOLE LOCATOR GAGE ADJUSTMENT

The Hole locator Gage can be set to hold the Hole Punches at a constant distance from the edge of the workpiece. The gage is held in place by one or two socket head caps screws. Before making any adjustment,

first, unplug the power cord. To adjust the position of the gage, loosen the cap screw(s), tap the gage into the desired position and retighten the cap screw(s).

USING THE WORK STAND

All models can be used with an accessory work stand for bench or table mounting of the Hole Puncher. The stand is standard with all models. To install the stand, first unplug the power cord., then mount the unit to the stand with the supplied hardware.

When using the stand, periodically check to make sure that the punched material (slugs) are not stacking up between the exit hole in the "C"-frame and the stand. Keep this area clear of accumulated slugs.

SELECTING PROPER DIES

Proper die selection is essential. Other than the obvious necessity of matching shaped punches and dies, there are two other basic selection factors that must be considered. The first is die clearance. Different material types and different material thicknesses require different clearances between the punch and die. In order to maintain the best possible hole while remaining within the tonnage capacity of the machine, it is essential to choose the die with the proper clearance. The second is the die angle. Most structural shapes can be punched with the standard

flat dies, but "I" -beams and most channels which have a 2-in-12 taper require the use of special 9-1/2 degree angled dies. Car and ship channel flanges and other structural shapes with a 2 degree taper can be punched with flat dies. Materials with a flange taper of less than 5 degrees can also be punched with the flat die, however, the hole will be slightly angled. Refer to specific information and tables within this manual for the proper punch and die combination.

NEW AND IMPROVED PUNCH RETAINING

New Quick Change Punch

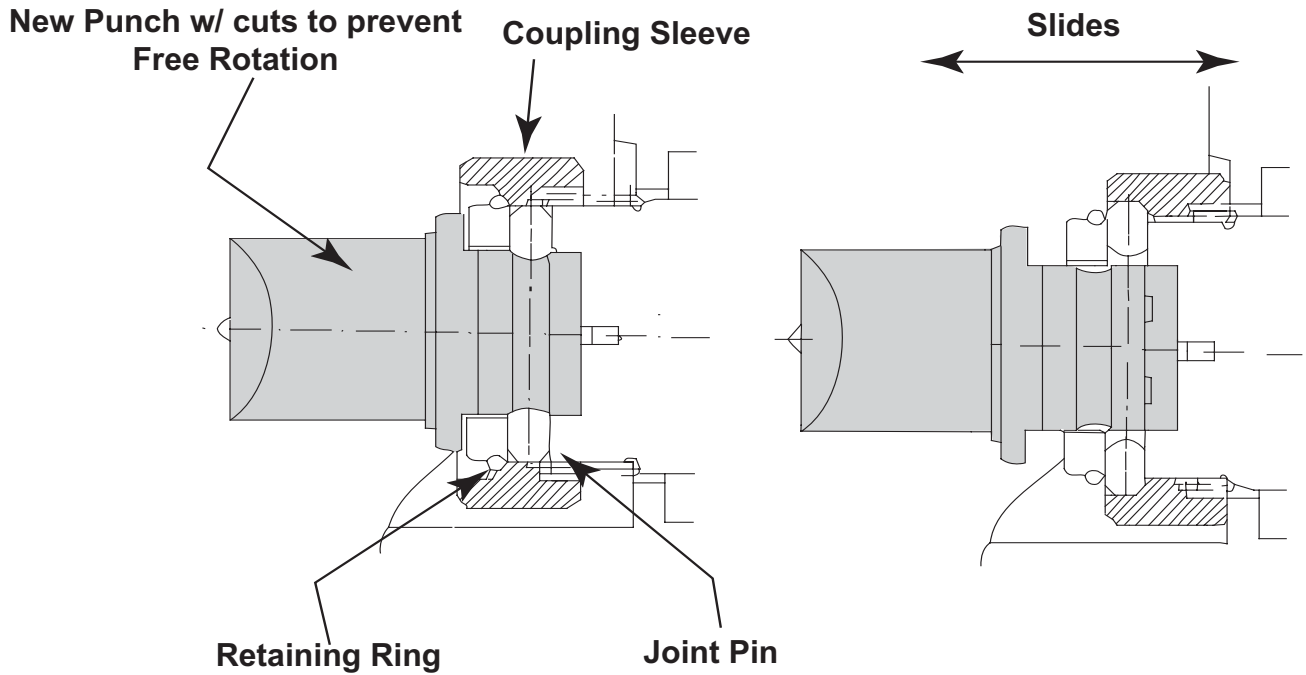

**** Make sure coupling sleeve is completely locked down to prevent punch from shifting.**

Old Style Punch and Retaining Nut

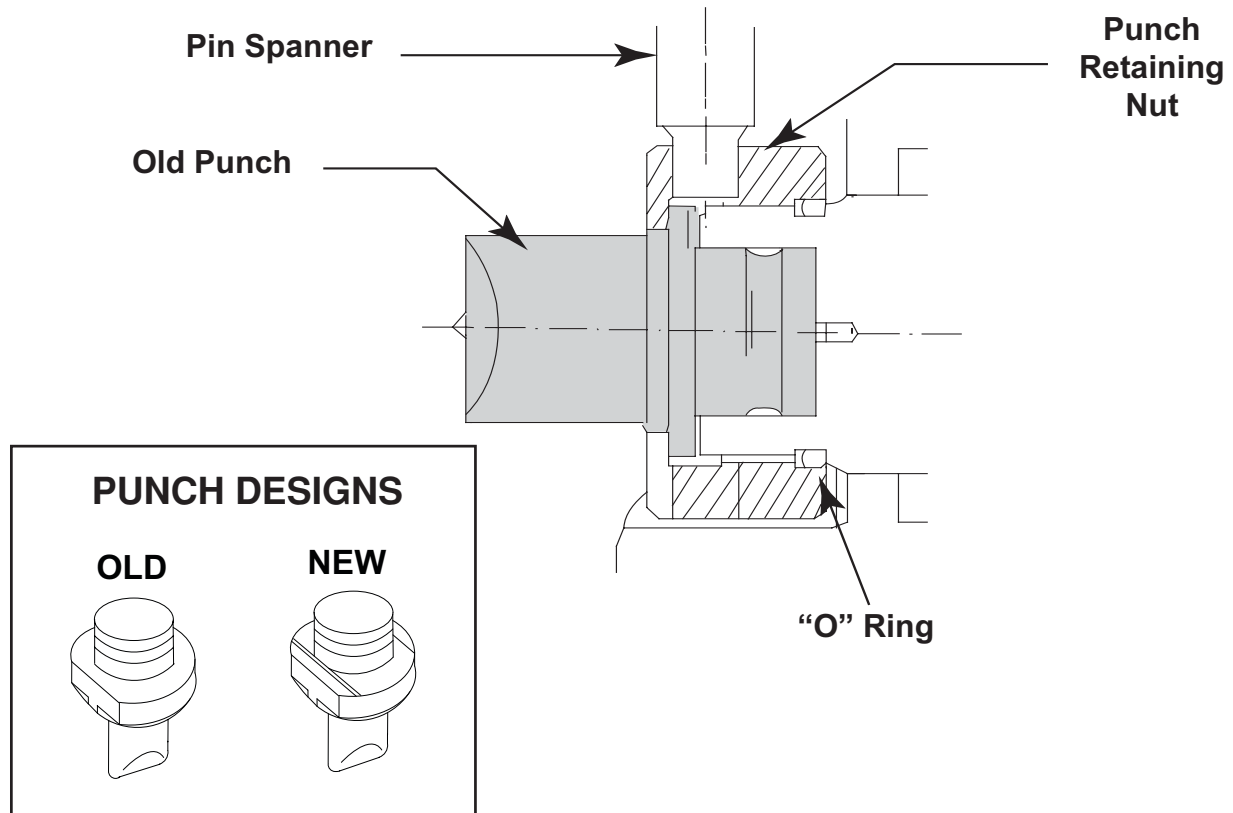

MAINTENANCE

In order to insure smoother operation and longer life of your hole puncher, the following maintenance should be done periodically, based on use.

1. Keep the machine clean. It is especially important to keep the sliding portion of the punch piston free from metal chips, scale, dirt, dust or other debris. To clean the punch piston, turn on the switch to move the punch piston almost to the bottom of its stroke. If necessary, cycle the punch several times to determine where the bottom of the stroke is, and to correctly position the punch piston.

Unplug the power cord. Wipe any debris from the exposed part of the punch piston.

2. Regularly tighten all fasteners and replace any worn components.

3. Check power cord, if cracked or frayed, return the machine to an authorized repair center for replacement.

4. Check oil level carefully, using the procedure below.

NOTE: *The internal components of the pump and piston area have very close clearances and are sensitive to damage from dust, dirt, contamination of the hydraulic fluid or improper handling. The disassembly of the pump housing requires special tools and training, and should be attempted by a qualified repair person. The improper servicing of electrical components can lead to conditions that could cause serious injury.*

ANY ATTEMPT BY UNAUTHORIZED PERSONNEL TO SERVICE THE INTERNAL COMPONENTS OF THE PUMP AREA WILL VOID THE WARRANTY.

ADDING OIL

Use of the correct hydraulic oil is essential. Approved oils are Shell "TELLUS Oil" and Exxon "TERESSTIC" (Part No. 75376). Grade #46 viscosity must be used. Check the unit specifications. Make sure that the work area and all equipment are clean so that no dirt, dust or other foreign material can get into the hydraulic oil or pump area.

1. Locate the socket head cap screw that plugs the oil port. It is just above the manual return lever on the right hand side of the Hole Puncher.

2. Lay the Hole Puncher on its left side so that the oil port is facing up.

3. Turn on the switch to move the punch piston almost to the bottom of its stroke. If necessary, cycle the punch several times to determine where the bottom of the stroke is, and to correctly position the punch piston. In this position, the maximum amount of oil has been drawn from the pump and the correct fill can be obtained.

4. Carefully open the oil port by removing the socket head cap screw.

5. Using the small squeeze bottle supplied with the Hole Puncher, carefully add hydraulic oil to completely fill the reservoir. Rock the Hole Puncher back and forth slightly several times to free any trapped air bubbles, then add additional oil if necessary.

6. Replace the cap screw and wipe up any excess oil.

7. Cycle the Hole Puncher several times with the Manual return Valve open, and again with the valve closed, to work any trapped air out of the system, then repeat the above procedure, making sure that the punch piston is almost at the bottom of the stroke before removing the cap screw from the oil port.

8. Add additional oil as necessary. If the unit was extremely low on oil, it may be necessary to repeat the procedure several times.

HELPFUL HINTS FOR HOLE PUNCHING

Each of the punches is provided with a sharp point at its center. If the hole locations are center punched, the point on the end of the punch may be used to "find" the center punched spot.

Also, for accurate and easy positioning of the punch to a hole location, the switch can be intermittently pulsed on and off to jog the punch down to the work surface.

If the position is not satisfactory, open the manual return valve to retract the punch for another attempt. This operation can also be performed with the manual return valve "cracked" open slightly to prevent full punching pressure from being developed. In this manner, the punch can be easily brought right down to the surface without beginning to punch the hole. If the location is satisfactory, close the valve and finish the operation.

75002.5A EXPLODED VIEW

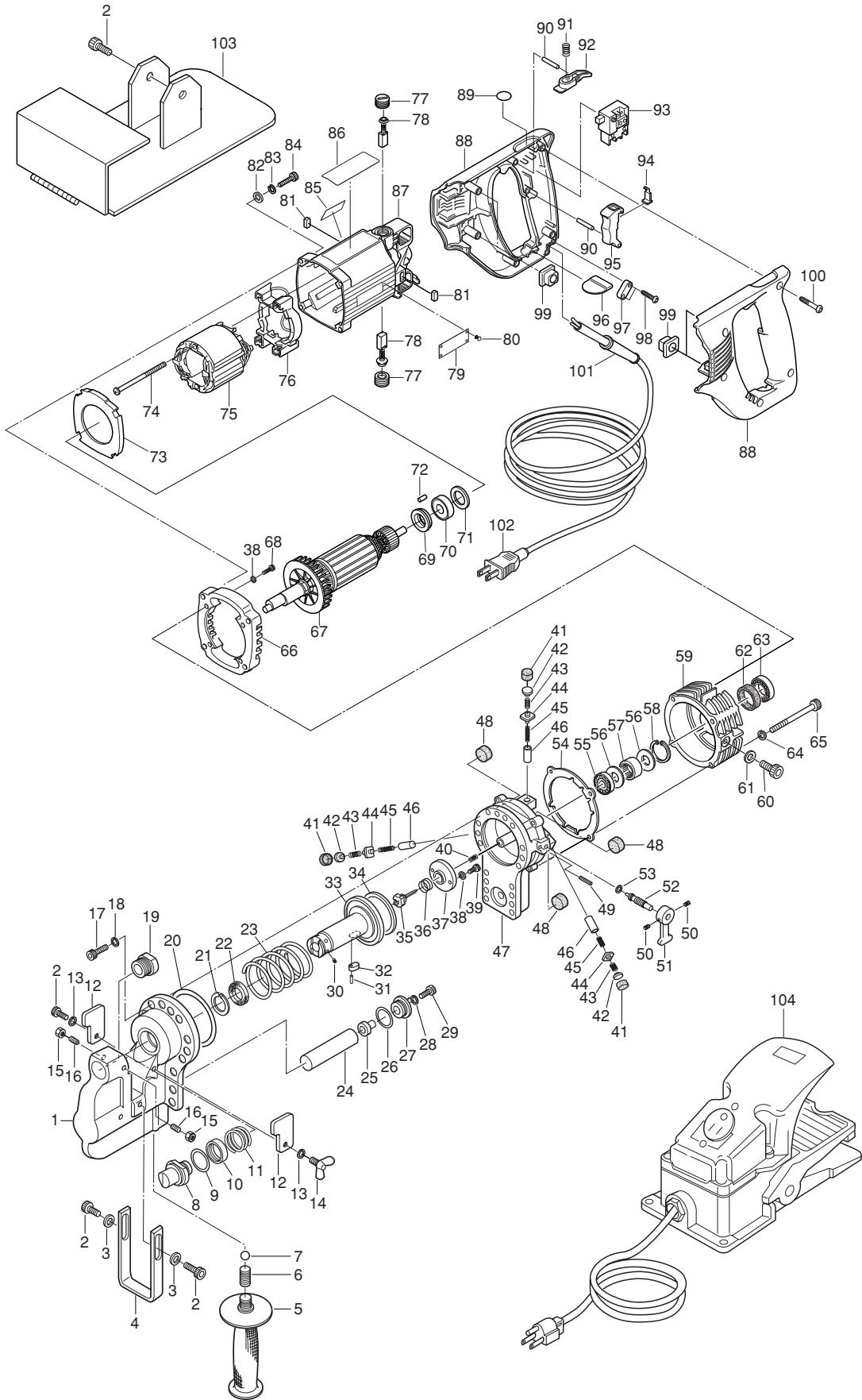

PARTS LIST - 75002.5A

DET. #	PART#	DESCRIPTION	QTY.
1	75177	"C" FRAME	1
2	75156	SCREW M6 X 15MM	6
3	75157	FLAT WASHER 6MM	2
4	75176	HOLE LOCATOR	1
5	75063	PUNCHER HANDLE	1
6	75192	SCR-SOC SET M10	1
7	75191	STEEL BALL BEARING	1
8	75427	9/16" PUNCH	1
9	75117	RETAINING RING	1
10	75115	COUPLING SLEEVE	1
11	75116	JOINT PIN SPRING	1
12	75131	STRIPPER	2
13	75162	WASHER-HELI LOCK	2
14	75175	SCR-WING HD M6 X 15MM	1
15	75091	NUT HEX M6	2
16	75189	SCR-SOC SET M6 X 20MM	2
17	75158	SCR-SHC M8 X 20 MM	18
18	75159	FLAT WASHER 8MM	18
19	75444	DIE -RD 9/16A	1
	75445	DIE -RD 9/16B	1
20	75185	"O"-RING	1
21	75152	BACKUP RING	1
22	75153	PACKING ROD SEAL	1
23	75187	PUNCH RETURN SPRING	1
24	75137	OIL BLADDER	1
25	75136	SCR- BLADDER	1
26	75190	"O"-RING	1
27	75188	SCR-BLADDER BUSHING	1
28	75155	WASHER-HELI LOCK	1
29	75138	SCR-BLADDER RET.	1
30	75114	JOINT PIN	6
31	75099	ROLL PIN	1
32	75135	PUNCH PISTON KEY	1
33	75118	PUNCH PISTON	1
34	75154	PACKING	1
35	75042	RELEASE VALVE	1
36	75043A	VALVE RETURN SPRING	1
37	75183	STOP PLATE	1
38	75101	FLAT WASHER	2
39	75102	SCR-SHC M4 X 6MM	2
40	75184	VALVE RELEASE SPRING	1
41	75049	SEAL-PACKING	3
42	75051	SPRING RETAINER	3
43	75052	CHECK VALVE SPRING	3
44	75050	CHECK VALVE	3
45	75053	PISTON RETURN SPRING	3
46	75048-A	PUMP PISTON 5.996 X 13MM	1-3
	75048-B	PUMP PISTON 5.997 X 13MM	1-3
	75048-C	PUMP PISTON 5.998 X 13MM	1-3
	75048-D	PUMP PISTON 5.999 X 13MM	1-3
	75048-E	PUMP PISTON 6.000 X 13MM	1-3
	75048-F	PUMP PISTON 6.001 X 13MM	1-3
	75048-G	PUMP PISTON 6.002 X 13MM	1-3
	75048-H	PUMP PISTON 6.003 X 13MM	1-3
	75048-I	PUMP PISTON 6.004 X 13MM	1-3
	75048-J	PUMP PISTON 6.005 X 13MM	1-3
47	75174	CYLINDER	1
48	75054	MAGNET	3

DET. #	PART#	DESCRIPTION	QTY.
49	75100	ROLL PIN	1
50	75160	SR-SET M6 X 8MM	2
51	75047	RETURN LEVER	1
52	75046	RETURN VALVE	1
53	75085	"O"-RING	1
54	75173	GASKET	1
55	75086	BALL BEARING	1
56	75055	SPACER	2
57	75088	ROLLER BEARING	1
58	75089	RETAINING RING	1
59	75861	PUMP CASE	1
60	75107	SCR-SHC M10 X 15MM	1
61	75090	SEAL WASHER	1
62	75084	OIL SEAL	1
63	75087	BALL BEARING	1
64	75862	WASHER HW5MM	4
65	75873	BOLT HB5 X 50MM	4
66	75874	SUB PLATE	1
67	75821	ARMATURE	1
68	75826	BOLT HB4 X 20MM	4
69	75822	PAPER WASHER	1
70	75823	BALL BEARING 608 LLB	1
71	75824	THURST WASHER 16MM	1
72	75825	RUBBER PIN 4MM	1
73	75827	FAN GUIDE	1
74	75828	SCREW 5 X 65MM	2
75	75829	FIELD 115V	1
76	75830	FIELD SUPPORT SET	1
77	75831	BRUSH CAP	2
78	75832	CARBON BRUSH (PAIR)	2
79	75864	CAUTION TAG	1
80	75833	RIVET	4
81	75834	ANTI VIBRATION RUBBER B	2
82	75835	FLAT WASHER 5MM	4
83	75836	SPRING WASHER 5MM	4
84	75837	BOLT HB 5 X 25MM	4
85	75865	WARNING TAG	1
86	75867	NAME TAG	1
87	75838	MOTOR HOUSING SET	1
88	75839	HANDLE SET	1
89	75840	LABEL	1
90	75841	PIN 3MM	2
91	75842	COMPRESSION SPRING 4MM	1
92	75843	ROCK BUTTON	1
93	75844	SWITCH TG71B	1
94	75845	SPACER	1
95	75846	SWITCH LEVER	1
96	75847	RUBBER PLATE	1
97	75848	CORD CLAMP	1
98	75850	SCREW X 18MM	2
99	75850	ANTI VIBRATION RUBBER A	4
100	75841	SCREW 4 X 25MM	5
101	75852	STRAIN RELIEF	1
102	75870	POWER CORD	1
103	75166	WORK STAND	1
104	75110	FOOT SWITCH	1

ROUND PUNCHES AND DIES FOR 75002.5A

Round Punch				Material		Die	
Size			No.	Thickness	Style	Size	No.
Nominal	Actual	Metric					
1/4"	.256	6.5mm	75421	5/64 (.078) to 1/8 (.125) 14 to 11 GA.	F, A, H	Die 1/4 A	75432
				>1/8 (.125) to 1/4 (.250) 10 to 3 GA.	F, A, H	Die 1/4 B	75433
5/16"	.315	8mm	75422	5/64 (.078) to 1/8 (.125) 14 to 11 GA.	F, A, H	Die 5/16 A	75434
				>1/8 (.125) to 1/4 (.250) 10 to 3 GA.	F, A, H	Die 5/16 B	75435
11/32"	.335	8.5mm	75423	5/64 (.078) to 1/8 (.125) 14 to 11 GA.	F, A, H	Die 11/32 A	75436
				>1/8 (.125) to 1/4 (.250) 10 to 3 GA.	F, A, H	Die 11/32 B	75437
3/8"	.394	10mm	75424	5/64 (.078) to 1/8 (.125) 14 to 11 GA.	F, A, H	Die 3/8 A	75438
				>1/8 (.125) to 1/4 (.250) 10 to 3 GA.	F, A, H	Die 3/8 B	75439
				19/64 (.297) max.	C	Die 3/8 C	75450
7/16"	.433	11mm	75425	5/64 (.078) to 1/8 (.125) 14 to 11 GA.	F, A, H	Die 7/16 A	75440
				>1/8 (.125) to 1/4 (.250) 10 to 3 GA.	F, A, H	Die 7/16 B	75441
				19/64 (.297) max.	C	Die 7/16 C	75451
1/2"	.512	13mm	75426	5/64 (.078) to 1/8 (.125) 14 to 11 GA.	F, A, H	Die 1/2 A	75442
				>1/8 (.125) to 1/4 (.250) 10 to 3 GA.	F, A, H	Die 1/2 B	75443
				19/64 (.297) max.	C	Die 1/2 C	75452
9/16"	.551	14mm	75427	5/64 (.078) to 1/8 (.125) 14 to 11 GA.	F, A, H	Die 9/16 A	75444
				>1/8 (.125) to 1/4 (.250) 10 to 3 GA.	F, A, H	Die 9/16 B	75445
				19/64 (.297) max.	C	Die 9/16 C	75453
5/8"	.625	15.9mm	75428	5/64 (.078) to 1/8 (.125) 14 to 11 GA.	F, A, H	Die 5/8 A	75446
				>1/8 (.125) to 1/4 (.250) 10 to 3 GA.	F, A, H	Die 5/8 B	75447
11/16"	.688	17.5mm	75429	5/64 (.078) to 1/8 (.125) 14 to 11 GA.	F, A, H	Die 11/16 A	75448
				>1/8 (.125) to 1/4 (.250) 10 to 3 GA.	F, A, H	Die 11/16 B	75449
3/4"	.748	19mm	75430	5/64 (.078) to 1/8 (.125) 14 to 11 GA.	F, A, H	Die 3/4 A	75729
				>1/8 (.125) to 3/16 (.188) 10 to 7 GA.	F, A, H	Die 3/4 B	75730
25/32"	.787	20mm	75431	5/64 (.078) to 1/8 (.125) 14 to 11 GA.	F, A, H	Die 25/32 A	75731
				>1/8 (.125) to 3/16 (.188) 10 to 7 GA.	F, A, H	Die 25/32 B	75732

OBLONG PUNCHES AND DIES FOR 75002.5A

OBLONG PUNCH			MATERIAL		DIE		
Nominal	Size		Part No.	Thickness	Style	Size	Part No.
	Actual	Metric					
1/4" x 1/2"	.256	6.5mm	75638	5/64 (.078) to 1/8 (.125) 14 to 11 GA.	F, A, H	Die 1/4 x 1/2 A	75643
	x .512	x 13mm		>1/8 (.125) to 1/4 (.250) 10 to 3 GA.	F, A, H	Die 1/4 x 1/2 B	75644
				19/64 (.297) max.	C	Die 1/4 x 1/2 C	75653
11/32" x 1/2"	.335	8.5mm	75639	5/64 (.078) to 1/8 (.125) 14 to 11 GA.	F, A, H	Die 11/32 x 1/2 A	75645
	x .512	x 13mm		>1/8 (.125) to 1/4 (.250) 10 to 3 GA.	F, A, H	Die 11/32 x 1/2 B	75646
				19/64 (.297) max.	C	Die 11/32 x 1/2 C	75654
7/16" x 5/8"	.433	11mm	75640	5/64 (.078) to 1/8 (.125) 14 to 11 GA.	F, A, H	Die 7/16 x 5/8 A	75647
	x .650	x 16.5mm		>1/8 (.125) to 1/4 (.250) 10 to 3 GA.	F, A, H	Die 7/16 x 5/8 B	75648
				19/64 (.297) max.	C	Die 7/16 x 5/8 C	75655
1/2" x 3/4"	.512	13mm	75641	5/64 (.078) to 1/8 (.125) 14 to 11 GA.	F, A, H	Die 1/2 x 3/4 A	75649
	x .768	x 19.5mm		>1/8 (.125) to 1/4 (.250) 10 to 3 GA.	F, A, H	Die 1/2 x 3/4 B	75650
9/16" x 13/16"	.551	14mm	75642	5/64 (.078) to 1/8 (.125) 14 to 11 GA.	F, A, H	Die 9/16 x 13/16 A	75651
	x .827	x 21mm		>1/8 (.125) to 1/4 (.250) 10 to 3 GA.	F, A, H	Die 9/16 x 13/16 B	75652

Legend

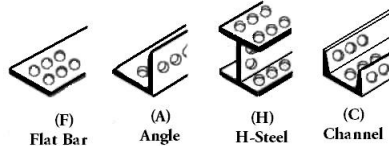

SQUARE PUNCHES AND DIES FOR 75002.5A

SQUARE PUNCH			MATERIAL		DIE		
Nominal	Size		Part No.	Thickness	Style	Size	Part No.
	Actual	Metric					
1/4"	.256	6.5mm	75800	>1/8 (.125) to 1/4 (.250) 10 to 3 GA.	F, A, H	Die 1/4 B	75804
5/16"	.315	8mm	75801	>1/8 (.125) to 1/4 (.250) 10 to 3 GA.	F, A, H	Die 5/16 B	75805
3/8"	.394	10mm	75802	>1/8 (.125) to 1/4 (.250) 10 to 3 GA.	F, A, H	Die 3/8 B	75806
7/16"	.433	11mm	75803	>1/8 (.125) to 1/4 (.250) 10 to 3 GA.	F, A, H	Die 7/16 B	75807

Troubleshooting

PROBLEM	CAUSE	SOLUTION
MOTOR RUNS BUT PUNCH PISTON DOES NOT COME OUT	MANUAL RETURN VALVE IS OPEN	CLOSE MANUAL RETURN VALVE
	OIL IS INSUFFICIENT	ADD OIL
	PISTON HAS NOT RETURNED COMPLETELY TO ITS HOME POSITION DUE TO STEEL CHIPS, DIRT OR OTHER DEBRIS ON THE EXPOSED PUNCH-HOLDER POSITION.	CLEAN DEBRIS FROM EXPOSED PUNCH-HOLDER PORTION OF PISTON ROD. PUSH PUNCH PISTON BACK TO ITS HOME POSITION.
	PUNCH PISTON RETURN SPRING IS TOO WEAK TO RETURN PUNCH ROD	HAVE MACHINE SERVICED BY THE FACTORY
PUNCH PISTON COMES OUT, BUT PUNCHING POWER IS TOO WEAK TO PUNCH	MANUAL RETURN VALVE IS NOT COMPLETELY CLOSED	CLOSE MANUAL RETURN VALVE
	OIL IS INSUFFICIENT OR AIR IS TRAPPED IN RESERVOIR	ADD OIL
	INTERNAL PUMP OR PISTON PARTS ARE WORN, DIRTY OR DAMAGED AND NOT FUNCTIONING PROPERLY	HAVE MACHINE SERVICED BY THE FACTORY
MOTOR DOES NOT ROTATE OR POOR ROTATION OF MOTOR	OPEN POWER CIRCUIT	CHECK PLUG, EXTENSION CORD, CIRCUIT BREAKER
	IMPROPER VOLTAGE	CHECK POWER SOURCE
	EXCESSIVE VOLTAGE DROP	EXTENSION CORDS ARE OF INSUFFICIENT WIRE SIZE FOR THE LENGTH OF THE CORD.
	WORN OR DAMAGED CORDS OR PLUGS. WORN CARBON BRUSHES. DAMAGED INTERNAL MOTOR PARTS	HAVE MACHINE SERVICED BY THE FACTORY
OIL LEAKING BETWEEN "C" FRAME AND CYLINDER OR BETWEEN CYLINDER AND PUMP HOUSING	BOLTS ARE NOT TIGHT	TIGHTEN BOLTS
	GASKET IS DAMAGED	HAVE MACHINE SERVICED BY THE FACTORY
OIL LEAKING AROUND PISTON OR FROM INTERNAL AREA	INTERNAL SEALS OR SURFACES ARE DAMAGED. OIL LEVELER SACK IS BROKEN	HAVE MACHINE SERVICED BY THE FACTORY
PUNCH DOES NOT STRIP OUT OF WORKPIECE AFTER PUNCHING	PUNCH OR DIE IS WORN	REPLACE
	IMPROPER DIE FOR MATERIAL OR THICKNESS	CHECK FOR PROPER PUNCH AND DIE SELECTION
	WORKPIECE WAS NOT UNDER BOTH STRIPPERS AND IS BINDING OR PUNCH	MAKE SURE THAT THE MATERIAL IS FULLY SEATED IN THE PUNCHING AREA

Commercial / Industrial Limited Warranty

Hougen Manufacturing, Incorporated warrants its Portable Magnetic Drills, Electro-hydraulic Hole Punchers for a period of (1) one year and other products for ninety (90) days from date of purchase against defects due to faulty material or workmanship and will repair or replace (at its option) without charge any items returned. This warranty is void if the item has been damaged by accident or unreasonable use, neglect, improper service, or other causes not arising out of defects in material or workmanship. No other expressed warranty is given or authorized. Hougen Manufacturing, Inc. disclaims any implied warranty of MERCHANTABILITY or FITNESS for any period beyond the expressed warranty and shall not be liable for incidental or consequential damages. Some states do not allow exclusions of incidental or consequential damages or limitation on how long an implied warranty lasts and, if the law of such a state governs your purchase, the above exclusion and limitation may not apply to you. This warranty gives you specific legal rights and you may also have other rights which vary from state to state.

To obtain warranty service, return the item(s), transportation prepaid, to your nearest Factory Authorized Repair Center or to Hougen Manufacturing, Inc., 3001 Hougen Drive, Swartz Creek, Michigan 48473.

Hougen Drills (Rotabroach Cutters) are warranted against manufacturing defects only. Subject to Hougen Manufacturing inspection.

THIS WARRANTY IS IN LIEU OF ANY OTHER WARRANTY, EXPRESSED OR IMPLIED, INCLUDING ANY WARRANTY OF MERCHANTABILITY OR FITNESS FOR A PARTICULAR PURPOSE

© 2003 Hougen Manufacturing, Inc.

Hougen-Ogura Patent Notice

Photographs and Specifications shown are accurate in detail at time of printing. Manufacture reserves the right to make improvements and modifications without prior notice.

Hougen, Hougen-Edge, Rotabroach, Punch-Pro, Trak-Star and the Hougen logo are proprietary trademarks of Hougen Manufacturing, Inc. Ogura and Ogura logo are proprietary trademarks of Ogura & Co., Ltd.

Factory Warranty Repair Services can be obtained by sending your product to:

Hougen Manufacturing, Inc.
3001 Hougen Drive
Swartz Creek, MI 48473
Attn: Repair Department

Hougen-Ogura™

Hougen Manufacturing, Inc.
P.O. Box 2005 • Flint, Mi. 48501-2005
3001 Hougen Drive • Swartz Creek, Mi. 48473
Phone (810) 635-7111 • Fax (810) 635-8277
www.hougen.com • info@hougen.com