

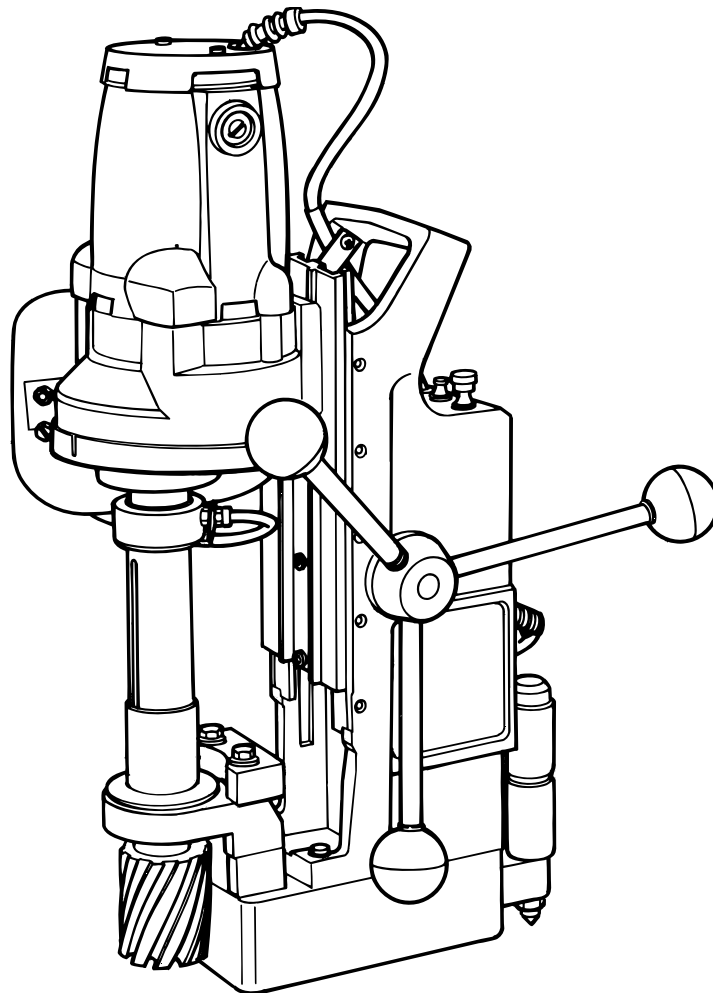

**MODELS 10914(S), 10909(S),
& 10909(S)AUS
PORTABLE MAGNETIC DRILLS**

OPERATOR'S MANUAL



FOR USE WITH "12,000-SERIES" HOUGEN[®] CUTTERS

HOUGEN®

Portable Magnetic Drills

Models 10914, 10914S, 10909, 10909S
& Aus Models

Welcome to Hougen

Congratulations on your purchase of the Hougen® Portable Magnetic Drill. Your model is designed to produce superior holes quickly and efficiently. Through constant innovation and development, Hougen is committed to provide you with hole-producing tools and products to help you be more productive.

Before attempting to operate your new Portable Magnetic Drill, please read all instructions first. These include the Operator's Manual and Warning Label on the unit itself. With proper use, care, and maintenance, your model will provide you with years of effective hole drilling performance. Once again, thank you for selecting our product and welcome to Hougen.

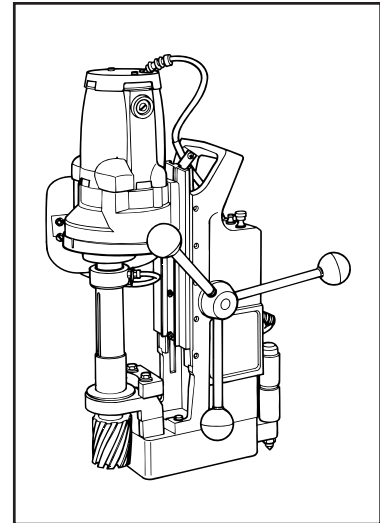

Commercial / Industrial Limited Warranty

Hougen Manufacturing, Incorporated warrants its Portable Magnetic Drills, Electro-hydraulic Hole Punchers, and Tornado II Paint shaker for one (1) year and other products for ninety (90) days from date of purchase against defects due to faulty material or workmanship and will repair or replace (at its option) without charge any items returned. This warranty is void if the item has been damaged by accident or unreasonable use, neglect, improper service, or other causes not arising out of defects in material or workmanship. No other expressed warranty is given or authorized. Hougen Manufacturing, Inc. disclaims any implied warranty of MERCHANTABILITY or FITNESS for any period beyond the expressed warranty and shall not be liable for incidental or consequential damages. Some states do not allow exclusions of incidental or consequential damages or limitation on how long an implied warranty lasts and, if the law of such a state governs your purchase, the above exclusion and limitation may not apply to you. This warranty gives you specific legal rights and you may also have other rights which vary from state to state.

To obtain warranty service, return the item(s), transportation prepaid, to your nearest Factory Authorized Repair Center or to Hougen Manufacturing, Inc., 3001 Hougen Drive, Swartz Creek, Michigan 48473.

Hougen Drills (Hougen Cutters) are warranted against manufacturing defects only. Subject to Hougen Manufacturing's inspection.

THIS WARRANTY IS IN LIEU OF ANY OTHER WARRANTY, EXPRESSED OR IMPLIED, INCLUDING ANY WARRANTY OF MERCHANTABILITY OR FITNESS FOR A PARTICULAR PURPOSE.

© 2004 Hougen Manufacturing, Inc.

Hougen Patent Notice

The products in this manual may be covered by one or more of the following U.S. patents, foreign patents, and pending patents:

4632610

4952102

5145296

Photographs and Specifications shown are accurate in detail at time of printing. Manufacture reserves the right to make improvements and modifications without prior notice.

Hougen, Hougen-Edge, and Punch Pro are proprietary trademarks of Hougen Manufacturing Inc. Ogura and the Ogura logo are proprietary trademarks of Ogura & co., Ltd. Vac-Pad are propriety trademark of Drillmate PTY, Ltd.

INDEX

WELCOME TO HOUGEN	2
COMMERCIAL WARRANTY	2
UNPACKING YOUR DRILL	3
SAFETY INSTRUCTIONS	4 - 5
SAFETY SWITCH INDICATOR LIGHT	5
OPERATING INSTRUCTIONS	6
INSTALLING HOUGEN CUTTERS	7
FRONT SUPPORT BRACKET SETUP	7
COOLANT BOTTLE ASSEMBLY	8
WIRING DIAGRAM	9
ELECTRICAL PANEL LAYOUTS	10
PANEL COMPONENT LISTING	11
DRILL MAINTENANCE	11
MOTOR LAYOUT AND COMPONENTS	12 - 13
EXPLODED VIEW	14
PARTS LISTING	15
WARRANTY SERVICE CENTERS	16

Unpacking Your New Portable Magnetic Drill

1. Open shipping carton and remove the literature and hardware packages.
2. Read and follow all Instructions before attempting to operate your new Magnetic Drill.
3. Complete and mail the Product Registration Card NOW. It is important that Hougen Manufacturing, Inc. have a record of product ownership.
4. Open hardware package and check contents.
10565 1/8" Allen Wrench for Gib Adjustment
10569 Feed handles (3)
10570 Feed handle knobs (3)
10727 3/16" Allen Wrench for reversing feed handle.
10730 Safety Chain
10779 7/32" Allen Wrench for cutter installation
13013 5/32" Allen Wrench for arbor installation and microswitch adjustment
5. Using the handle of the Magnetic Drill, lift unit out of the shipping case.
6. Remove all packing and securing material from the drill unit.
7. Screw the three Knobs (10570) onto the three feed handles (10569) and then screw the handles into the hub. Do not overtighten.
8. Your Magnetic Drill was factory adjusted prior to shipping. Check to make sure that all gib adjustment screws, motor mount screws, front support bracket screws, and magnet mounting screws are snug and have not vibrated loose in transit.
9. Your New Magnetic Drill comes complete with arbor mounted. The 3/4" diameter arbor bore fits all 3/4" - shank "12,000-Series" Hougen Cutters. A 1/2" diameter bore Arbor Adapter (10851), for mounting 1/2" shank "12,000-Series" Hougen Cutters, is optional.

SAFETY FIRST

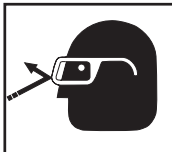

Always wear eye protection while using cutting tools, or in the vicinity of cutting.



CAUTION! Cutters are sharp. Wear gloves when installing or removing cutter from arbor. Do not grab a rotating cutter.



CAUTION! The slug is ejected at the end of the cut. Do not aim cutter or arbor so that ejected slug may hit someone around, or below you.



CAUTION! To prevent electric shock, do not use power tools near wet areas, or where power tool may become wet.

Important Safety Instructions



WARNING: When using electric tools, basic safety precautions should always be followed to reduce the risk of fire, electric shock, and personal injury, including the following:

1. Read All Instructions

2. Grounding Instructions

This tool should be grounded while in use to protect the operator from electric shock. The tool is equipped with a 3-conductor cord and a 3-prong grounding type plug to fit the proper grounding type receptacle. The green (or green and yellow) conductor in the cord is the grounding wire. Never connect the green (or green and yellow) wire to a live terminal. (Refer to Plug Diagram) Section A

3. Safe Electrical Connection

Your Mag Drill is rated for use on 115VAC (Plug A) or 230V (Plug B) at 50-60Hz. Do not attempt to use drill on power sources rated other than this. Wet electrical connections are shock hazards. To prevent the cutting fluid from traveling along the cord and contacting the plug or power outlet, tie a drip loop in the power cord. Also elevate extension cords or gang box connections.

4. Extension Cords

Use only 3-wire extension cords that have 3-prong grounding type plugs and 3-pole receptacles that accept the tool's plug. Replace or repair damaged cords. Make sure the conductor size is large enough to prevent excessive voltage drop which will cause loss of power and possible motor damage.

5. Do Not Force Tool

It will do the job better and faster at the rate for which it was intended.

6. Keep Work Area Clean

Cluttered areas and benches invite injuries. Keep dirt and chips from under the Cutter area.

7. Consider Work Area Environment

Do not expose tool to rain.
Do not use tool in damp or wet locations.
Keep work area well lit.
Do not use tool in presence of flammable liquids or gases. Disconnect from power source when changing cutters or maintaining drill.

8. Guard Against Electric Shock

Prevent body contact with grounded surfaces. For example: pipes, radiators, ranges, refrigerator enclosures.

9. Keep Children Away

Do not let visitors contact tool. All visitors should be kept away from work area while in use.

10. Store Idle Tools

When not in use, tools should be stored in a dry, and high or locked-up place — out of reach of children.

11. Use Right Tool

Do not force small tool or attachment to do the job of a heavy duty tool.
Do not use tool for purpose not intended — for example — do not use a circular saw for cutting tree limbs or logs.

Extension Cord Table

LENGTH OF CORD, FEET	RECOMMENDED WIRE GAUGE	RECOMMENDED WIRE GAUGE
	115V MOTOR 10 - 12 AMPS	230 V MOTOR 5 - 6 AMPS
UP TO 25	16	18
26 - 50	14	18
51 - 100	10	16
101 - 200	8	14
201 - 300	6	12
301 - 500	4	10

Plugs and Receptacles

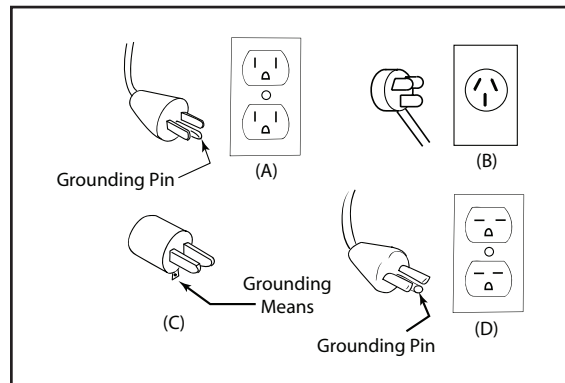

12. Non-Conforming Cutting Tools

Your Mag Drill is designed to use Hougén Cutters. The use of drilling tools having different shank styles is not recommended as they may not tighten securely in the drill arbor with risk of accident or injury.

13. Secure Work

Use clamps or a vise to hold work. It is safer than using your hand and it frees both hands to operate tool.

14. Always Wear Safety Glasses or Goggles

15. Dress Properly

Do not wear loose clothing or jewelry. They might entangle with spinning chips or get caught in moving parts. Rubber gloves and nonskid foot wear are recommended when working outdoors. Wear sturdy leather gloves when working indoors. Wear protective hair covering to contain long hair.

16. Do Not Abuse Cord

Never carry drill unit by its cord or yank it to disconnect from receptacle. Keep cord away from heat, oil, and sharp edges.

17. Do Not Overreach

Keep proper footing and balance at all time.

Important Safety Instructions - Continued

18. Maintain Tools With Care

Keep tools sharp and clean for better and safer performance. Do not use dull or broken Hougen Cutters. Follow instructions for lubricating and changing accessories. Inspect tool cords periodically and, if damaged, have repaired by authorized service facility. Inspect extension cords periodically and, if damaged, have repaired by authorized service facility. Keep handles dry, clean, and free from oil and grease.

19. Disconnect Tools

Disconnect when not in use, before servicing, and when changing cutters or accessories.

20. Remove Adjusting Keys and Wrenches

Form a habit of checking to see that keys and wrenches are removed from tool before turning it on.

21. Check Damaged Parts

Before further use of the drill, a part that is damaged should be carefully checked to determine that it will operate properly and perform its intended function. Check for alignment of moving parts, binding of moving parts, breakage of parts, mounting, and any other conditions that may affect its operation. A part that is damaged should be properly repaired or replaced by an authorized service center unless otherwise indicated elsewhere in this operator manual. Do not operate tool if switch does not turn it on and off.

22. Stay Alert

Watch what you are doing and use common sense. Do not operate tool when you are tired. Have defective switches replaced by authorized service center.

23. Outdoor Use Extension Cords

When tool is used outdoors, use only extension cords intended for use outdoors and so marked.

24. Additional Safety Precautions

Arbor and cutter should never be used as a hand-hold. Keep hands and clothing away from all moving parts. Do not use Hougen Cutters where ejected slug might cause injury (slug ejected at end of cut). Also, adhere to all operating instructions. Do not drill through any surface that may contain live electrical wiring. Drilling into a live wire could cause exposed metal parts of the drill to be made live. Remove chips wrapped around Cutter and arbor after each hole. With motor off and power disconnected, grasp chips with leather gloved hand or pliers and pull while rotating counterclockwise. Should the cutter become jammed in the work, stop the unit immediately to prevent personal injury. Disconnect the drill from the power supply and loosen jammed cutter by turning the arbor counterclockwise. Never attempt to free the jammed cutter by starting the motor. Service at authorized repair center only.

25. Operating Near Welding Equipment

DO NOT operate this unit on the same work surface that welding is being performed on. Severe damage to the unit, particularly the power cord, could occur. This could also result in personal injury to the operator.

26. Circuit Breaker

Changing of the circuit breaker to a higher amp rated breaker, or bypassing the circuit breaker is not recommended and will void product warranty.

27. Circuit Breaker Operation

The circuit breaker is a thermal breaker. When it reaches the higher temperature rating it will trip and cause the unit to shut down. This is a protective device and can be reset after 5 to 10. To reset the breaker, press the breaker button back in. If it does not reset, let the unit cool a little longer until you can push the button in and it stays in position.

28. Safe Electrical Connection

Wet electrical connections are shock hazards. To prevent the cutting fluid from traveling along the cord and contacting the plug or power outlet, tie a drip loop as shown. Also elevate extension cords or gang box connections.

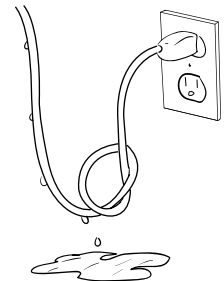

29. Save these Instructions.

SAFETY SWITCH INDICATOR LIGHT

The Safety Switch Indicator Light is a New Standard Safety Feature on 10914(S) magnetic drills. Its purpose is to inform the user that an unsafe condition exists or the safety switch needs adjusting.

If light is Green:

In normal operation the safety switch light will be green. Motor "On" and "Off" Switches function normally.

If light is Red:

A condition with the safety switch exists that needs to be corrected.

Possible causes:

- Safety Switch is out of adjustment (See Page 6).
- Safety Switch is defective. Have drill serviced.
- Uneven work surface or material. Check work surface for flatness.
- Dirt or chips under magnet. Clean work surface.
- Too thin material. Make sure material is at least 3/8" thick.

HOUGEN MANUFACTURING RECOMMENDS THAT CONDITIONS ARE CORRECTED SO LIGHT TURNS GREEN. THIS ALLOWS FOR THE UNIT TO BE OPERATED IN A SAFE MANNER.

When light is Red the motor will still function, but "ON" switch becomes a momentary switch. (The switch must be held down to operate motor.)

For any questions please contact Hougen Manufacturing's Technical Service at (810) 635-7111.

Operating Instructions

Always remember that the magnet's holding power is directly related to the workpiece thickness and surface condition. Since magnetic attraction diminishes with thinner material or rough surfaces, mechanical clamping of drill unit to workpiece should be used when cutting thin material (3/8" or less) or material with uneven surfaces.

Note: Always form a loose knot in the power cord close to the molded plug. This prevents cutting fluid from running down the cord and into the power receptacle. (Refer to the diagram within the Safety Instructions in this manual)

1. Make sure workpiece and bottom of magnet are free of chips, oil, etc.
2. Secure unit to workpiece with safety chain.
3. Position drill by sliding it and gently feeding Arbor so that pilot point is touching center of hole to be drilled.
4. Turn magnet ON by pressing the magnet ON button.
5. Move Impactor Slide Hammer up and down several times, rapping base sharply to insure Impactor Point is seated in workpiece and magnet is flush with workpiece.
6. Turn Feed Handle, raising the cutter until the pilot is above the work surface.
7. Open the cutting fluid valve several full turns (Models 10909 and 10914 only)
8. Make certain that cutter is clear of workpiece and turn motor On by pressing the motor START button.
9. Feed the cutter slowly into workpiece. Only after cutting path is established to a depth of about 1/16" can full force be applied to feed handles.
10. Ease up on feed pressure as cutter starts breaking through.
11. At conclusion of cut, turn motor OFF by pressing motor STOP button. Turn feed handles to raise Arbor thereby ejecting the slug if it hasn't already fallen free.
12. Turn magnet OFF by pressing the magnet OFF button. As the magnet de-energizes, the rear of the magnet should lift up off the work surface.
13. **Disconnect from power source.**
14. If necessary, remove chips from cutter and magnet., preferably wearing leather work gloves and/or with pliers.
15. Disconnect safety chain and you are ready to move unit to new drilling position.

Special Instructions for horizontal or Overhead Operation

1. **Always Use Safety Chain.**
2. Use grease or animal-fat base solid lubricant applied liberally to cutter.
3. For horizontal use, apply cutting fluid to external parts of cutter with plastic bottle or oiling can.

Adjustment of Gibs

1. Loosen all Gib Screws (40237)
2. Feed the drill in and out a few times and then, with top of motor slide flush with top of housing, tighten the Gib Screws until you feel them touch the Steel Gib (40225)
3. Feed the drill in and out again.
4. Adjust Gib screws so that there is uniform pressure from top to bottom. (Top of motor slide flush with top of housing)
5. Turn each Gib Screw in about 1/8 to 1/4 turn, depending upon your preference.
6. Gibs should be tight enough so that slide moves in and out smoothly with no wobble or shaking. (looseness will cause cutter breakage)

Safety Switch Adjustment

1. Unplug unit from power source and place it on a flat sheet of steel that is at least 3/8" thick. Only magnet portion should be on steel plate. Rear support block (containing Glide Post and Impactor) should hang over the edge of the steel plate.
2. Remove Access Hole Screw (10977) from back of housing.
3. Insert 5/32" Allen Wrench into access hole and back off (counterclockwise) Microswitch Adjusting Screw (10969) about three full turns.
4. Plug unit into power source and turn magnet ON. Depress and hold motor START switch ON while simultaneously turning Microswitch Adjusting Screw clockwise until motor starts. Once the motor starts release the Motor On Switch. Turn the adjusting screw 1-1/2 turns clockwise. This will set the Microswitch.

Testing of Microswitch

1. Plug unit into power source. Turn Magnet and motor switches ON. Strike side of magnet at rear with a rubber hammer. Motor should shut off before the magnet moves 1/2" in any direction. If the test was successful, replace the Access Hole Screw (10969). If the unit failed the test, recheck the Microswitch Adjustment.

NOTE: Safety switch adjustment should be checked regularly following the procedures outlined above.

#1 cause of cutter breakage and prematurely dull teeth is too little feed pressure

INSTALLING HOUGEN CUTTER IN ARBOR

1. Disconnect power source.
2. Lay drill on its side with feed wheel up to be sure arbor clears table if unit is in normal operating position.
3. Turn feed handles until cutter mounting set screws are exposed and then completely remove the set screws.
4. Insert proper pilot into shank end of the cutter.
5. Insert the Cutter until flats on cutter shank are aligned with set screw holes and is exactly perpendicular to the axis of set screw hole.
6. Insert Set Screws and tighten.

NOTE: Arbor, Hougén part number #03736 and #40242 applies only to Models 10909 and 10914.
Arbor, Hougén part number #03737 applies ONLY to "S" Models.

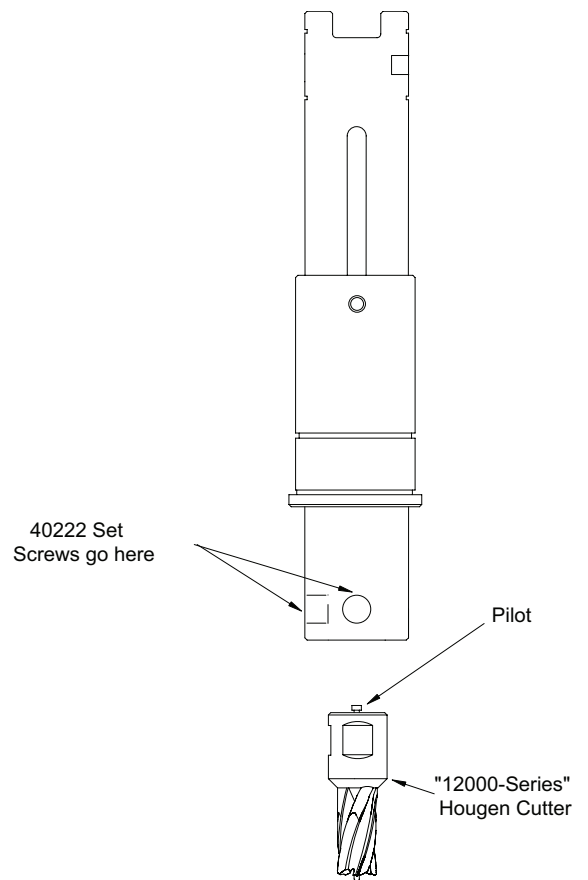

Adjusting Arbor Support Bracket for Depth

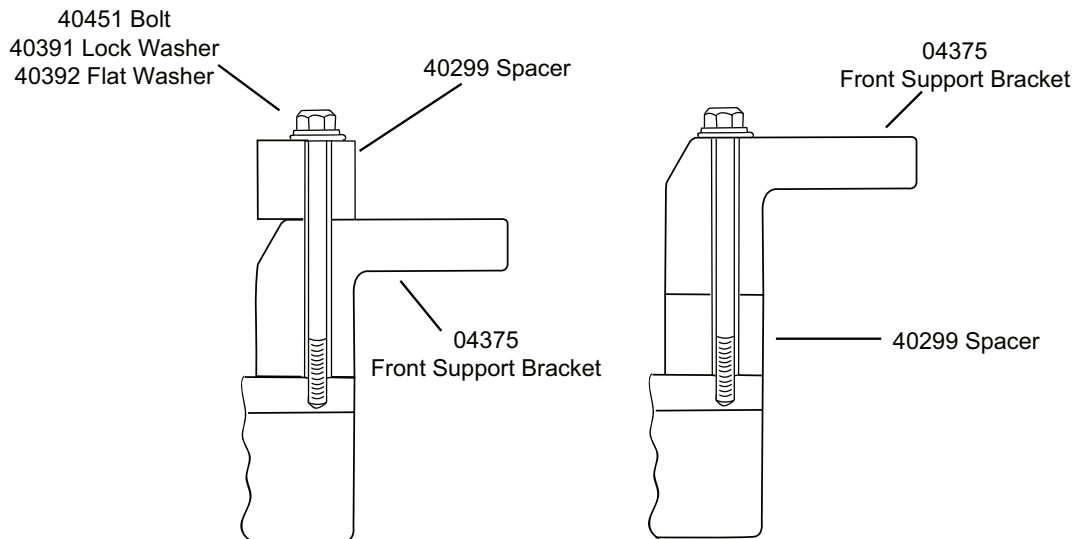

1" & 2" Depth of Cut

3" Depth of Cut

NOTE : Spacers must always be installed with short side toward arbor

COOLANT BOTTLE ASSEMBLY - P/N: 40442

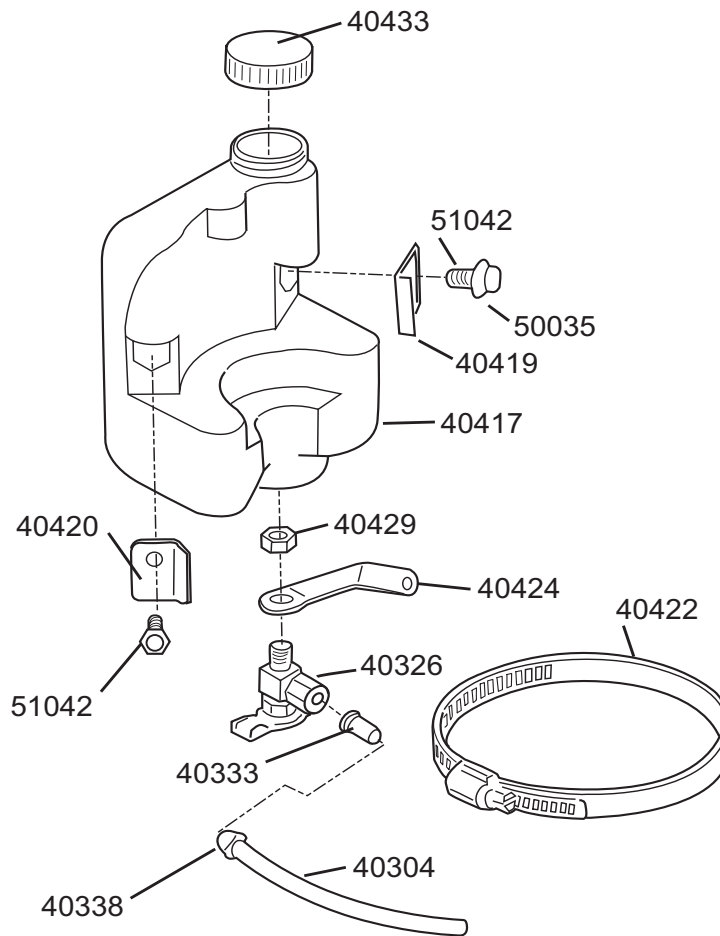

Checking Operation of Automatic Cutting Fluid Inducer

Note: The automatic cutting fluid inducer system works on a gravity flow basis. Therefore, it is only effective when the drill is mounted on a horizontal or slightly inclined work surface.

1. With Magnetic Drill in operation position, turn feed handle so that the cutter and pilot are above the work surface.
2. Fill cutting fluid bottle with cutting fluid.
3. To test automatic cutting fluid inducer (with the magnet ON and motor OFF), feed the arbor gently toward the work surface until the pilot is pushed up into the cutter. Open the needle valve until fluid is visible filling the plastic tube. Fluid should filter down onto the work surface through the groove in the pilot.
4. To insure proper cutter lubrication, always make sure that the slot in the pilot is kept clean from residual buildup.

Checking Operation of Cutting Fluid Reservoir (10909S & 10914S)

1. With magnetic drill in operating position, turn feed handle so that cutter and pilot are above the work surface.
2. With magnet turned ON and Motor OFF, fill reservoir by introducing cutting fluid through slots in Arbor. Cutting fluid should not leak out.
3. Test metering capabilities of Arbor/Cutter/ Pilot assembly (magnet ON-motor OFF) by feeding the Arbor gently toward work surface until pilot is pushed up into Cutter, thus allowing fluid to filter down onto work surface through groove in pilot.
4. For proper lubrication, all cutting fluid in reservoir should empty onto work surface in no less than 15 seconds and no more than 30 seconds.

MODEL 10914(S) & 10909(S) HOOK UP DIAGRAM

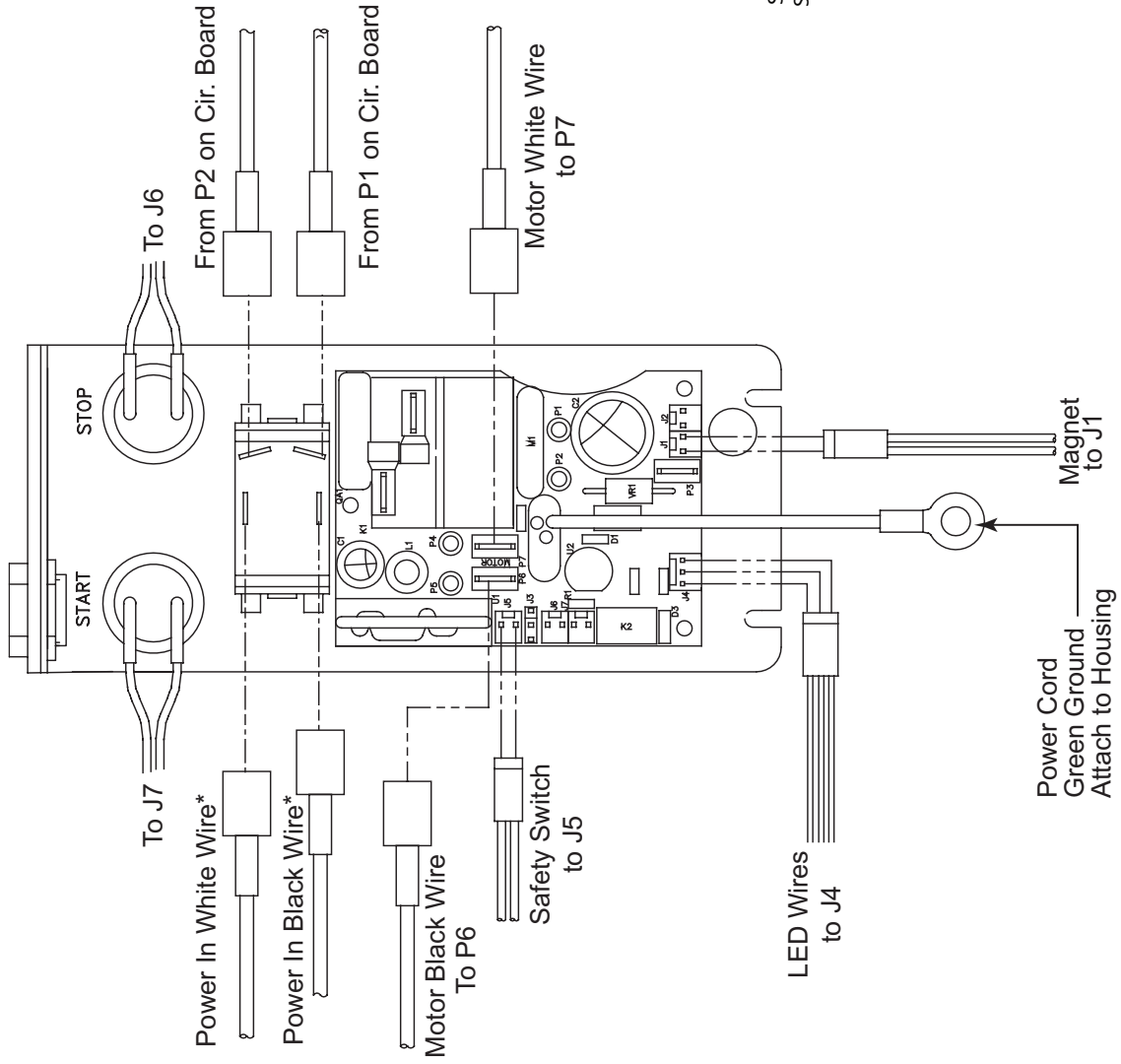

* Power Wires route through center of circuit board

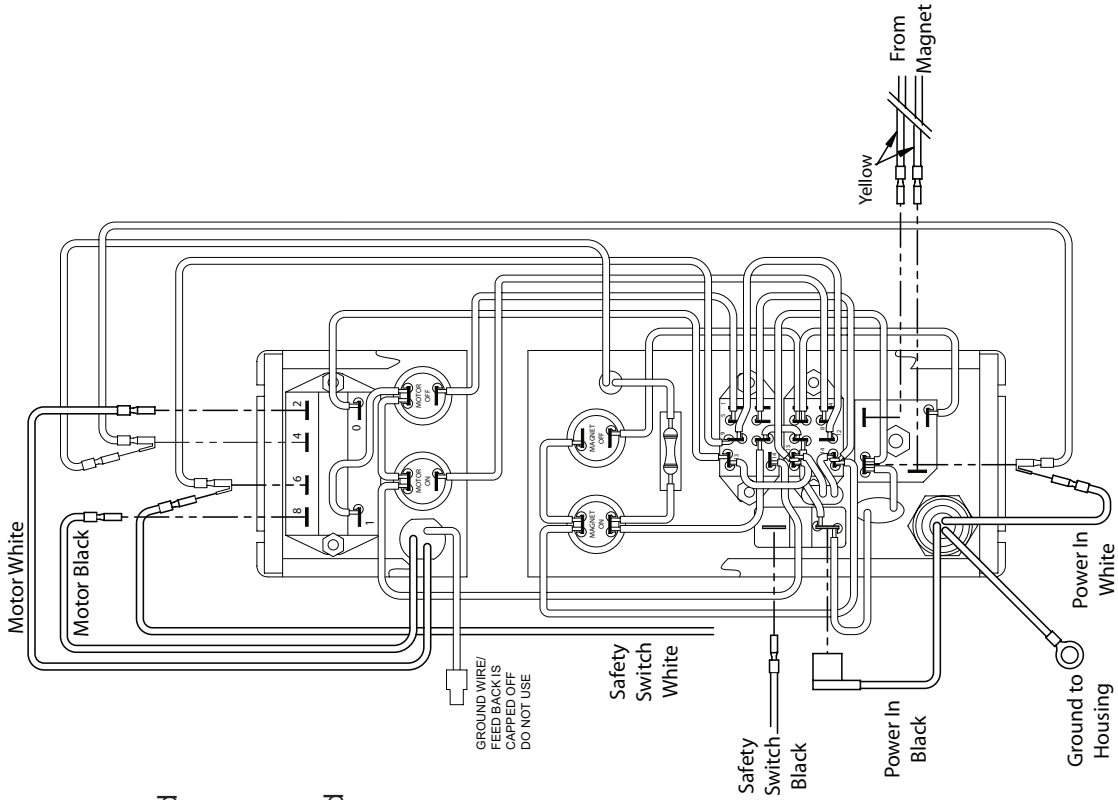

MODEL 10914 AND 10914S PANEL COMPONENTS

Panel Assembly

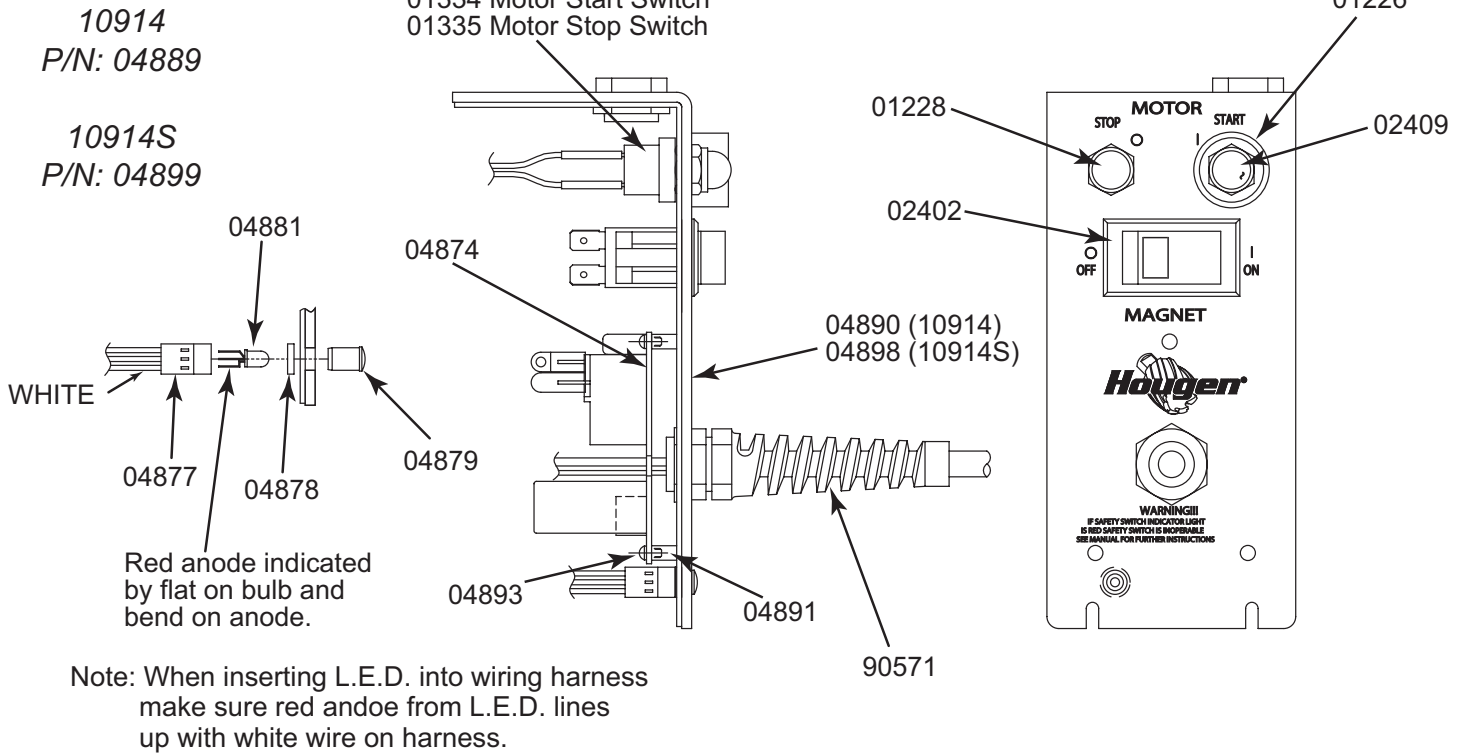

MODEL 10909 AND 10909S PANEL COMPONENTS

Panel Assembly P/N: 01086

Aus Panel Assembly P/N: 01086AUS

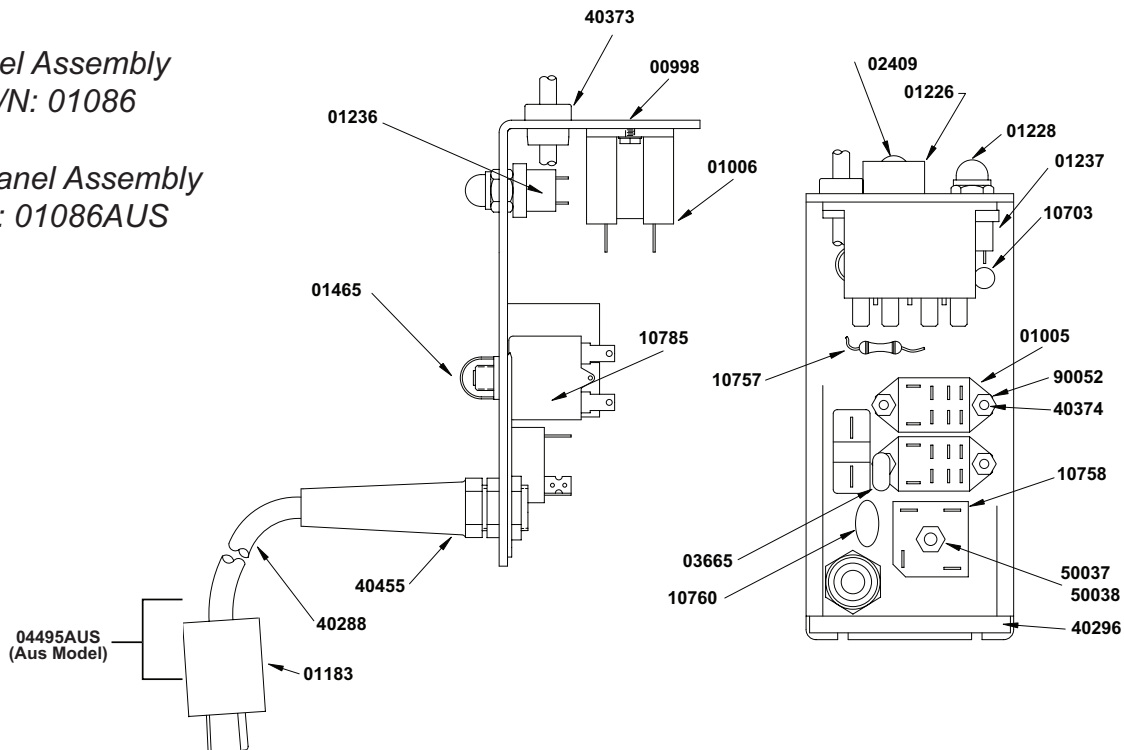

10909(S) & 10914(S) Panel Components

Part #	Description	Quan.
00998	Faceplate 10909	1
01005	Relay-Logic 230V (10909)	2
01006	Relay-Power (230V) 10909	1
01183	Plug 250V (10909)	1
01226	Switch Guard	1
01228	Switch Seal Red/Off	2
01236	Push Button Switch On (10909)	2
01237	Push Button Switch Off (10909)	2
01334	Motor/Magnet On Switch (10914)	2
01335	Motor/Magnet Off Switch (10914)	2
01465	Circuit Breaker Boot (10909)	1
02402	Face Plate (10914)	1
02409	Switch Seal Green	2
03665	Snubber Circuit (10909)	1
03907	Faceplate (10914S)	1
04495AUS	Power Cord Assembly (Aus Model)	1
04874	Circuit Board (10914)	1
04877	Wire Harness (10914)	1
04878	Spacer LED (10914)	1
04879	Lens Cover LED (10914)	1

Part #	Description	Quan.
04881	LED (10914)	1
04890	Faceplate (10914 Only)	1
04891	Spacer (10914)	3
04893	Phillips Screw	3
04898	Faceplate (10914S Only)	1
10703	LED (10909)	1
10757	Resistor 1 Meg (10909)	1
10758	Rectifier Fullwave (10909)	1
10760	Surge Suppressor (10909)	1
10785	Circuit Breaker (10909)	1
40288	Cord 16/3 (10909)	1
40373	Strain Relief	1
40374	Hex Nut #106-32 (10909)	6
40455	Strain Relief (10909)	1
50037	Hex Nut #10-32 (10909)	1
50038	Lock Washer (10909)	1
90571	Power Cord Assy. (10914)	1

Drill Maintenance

In order to minimize wear on moving parts and insure smoother operation and longer life, the following maintenance should be done periodically, based on use.

- At intervals of 500 holes or 10 hours of actual running time, check all fasteners for tightness and retighten if necessary. This is especially important for fasteners required for smooth, efficient cutting action. These include: Gib screws and nuts, motor hold down screws, skid plate screws, bracket mounting screws and nuts, housing bolts, clamp screw and front support bracket bolts.
- Coolant bottle must be attached to inducer under pressure with shut-off valve open to lubricate inducer o-rings whenever motor, is running.
- Apply grease to slide dovetails, brass gibs, and the feed gear rack. (For best results, use Shell Cyprina-RA or equivalent.)
- Remove front support bracket from arbor and pack bearing with grease. (Shell Cyprina-RA or equivalent)

Motor Exploded View and Parts List

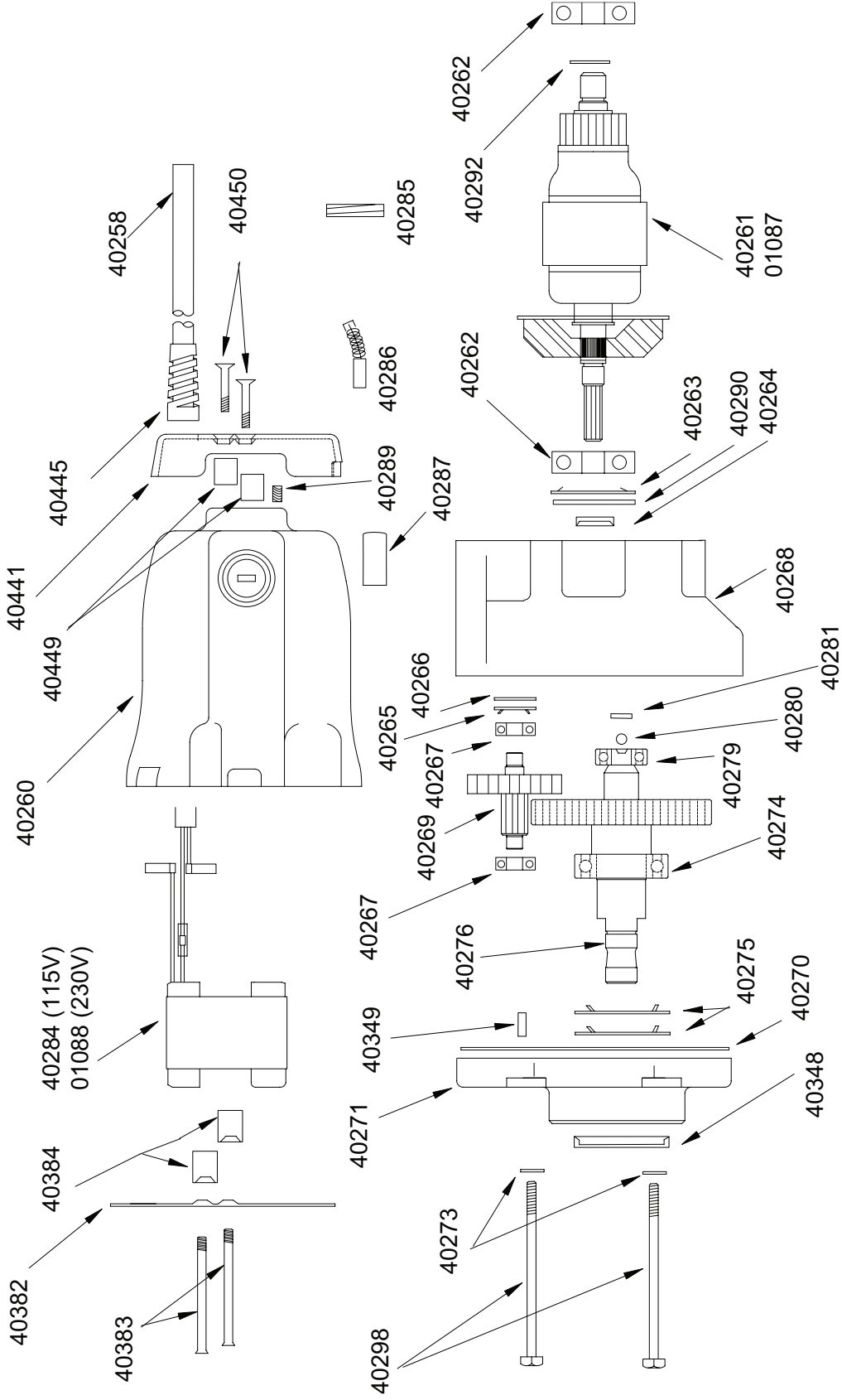

- 40287** Torque to 4 - 6 in/lb
- 40383** Torque to 15 - 25 in/lb (Use Loctite® #242)
- 40287** Loctite® #271 to outside of Brush Holder

Motor Bolt Sequence

1. Tighten bolts in the sequence shown to 5 - 10 in/lb.
2. Retighten bolts in the same sequence to 35 - 40 in/lb.

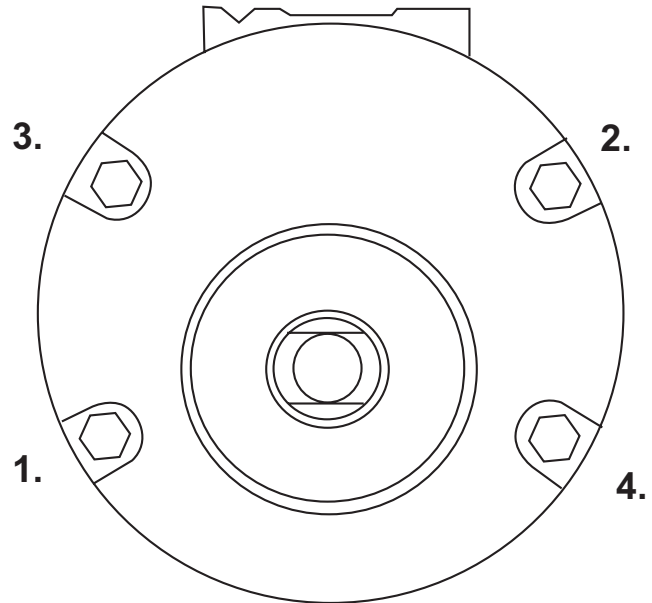

Motor Parts List

Part No.	Description	No. Req'd.	Part No.	Description	No. Req'd.
01087	Armature Assembly 230V	1	40280	Ball	1
01088	Field Assembly 230V	1	40281	Motor Slug	1
04204	Motor Cord (3 wire)	1	40284	Field Assembly 115V	1
04308	Field Assembly (3 wire)	1	40285	Brush Plug	2
40258	Motor Cord	1	40286	Brush, Carbon	2
40260	Housing, Brush End	1	40287	Brush Holder	2
40261	Armature Assembly 115V	1	40289	Screw #10-32 x 1/4"	2
40262	Bearing	2	40290	Washer	1
40263	Spring, Flat	1	40292	Retaining Ring	1
40264	Seal	1	40298	Screw 1/4-20 x 3-1/2"	4
40265	Spring, Flat	1	40348	Seal	1
40266	Washer	1	40349	Plug	1
40267	Bearing	2	40350	Syntech Grease	8 oz.
40268	Housing, Gear	1	40382	Baffle	1
40269	Gear Cluster	1	40383	Screw #10-32	2
40270	Gasket	1	40384	Baffle Spacer	2
40271	Cap, Gear Housing	1	40441	End Cap	1
40273	Lock Washer 1/4"	4	40445	Strain Relief	1
40274	Bearing	1	40449	Spacer	2
40275	Spring, Flat	2	40450	Screw #10-32 x 1"	2
40276	Gear Output	1	90424	Brush Holder Clip	2
40279	Bearing	1			

MODEL 10909(S) AND 10914(S) EXPLODED VIEW

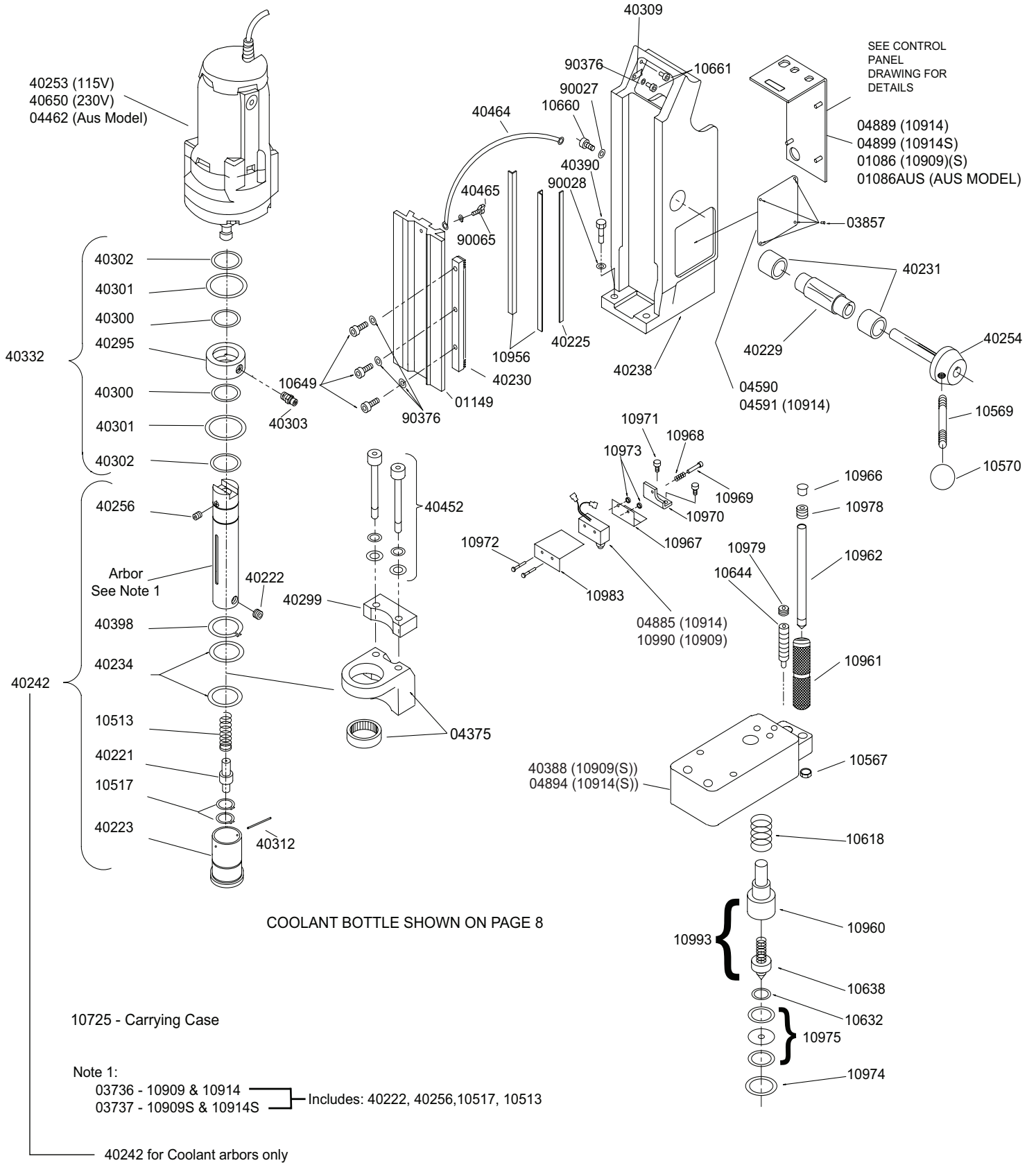

PARTS LIST

Part No.	Description	No. Req'd.	Part No.	Description	No. Req'd.
01086	Control Panel 230V	1	40230	Gear Rack	1
01086Aus	Control Panel (Aus Model)	1	40231	Bushing - Bronze	2
03736	Arbor 10909 & 10914	1	40234	Thrust Washer	2
03737	Arbor 10909S & 10914S	1	40237	Set Screw 1/4-28	5
04375	Arbor Supp. Brkt. Assy	1	40238	Housing	1
04462	230V Aus Replacement Motor	1	40242	Arbor Assy w/ejector (coolant)	1
04590	Warning Label	1(2)	40253	115V Replacement Motor	1
04591	Warning Label (10914)	1	40254	Hub Assy.	1
04885	Safety Switch (10914)	1	40256	Set Screw 5/16-18	1
04889	Control Panel (10914 Only)	1	40294	Motor Slide	1
04894	Magnet (10914)	1	40295	Inducer	1
04899	Control Panel (10914S Only)		40297	Screw - Slotted Hex	4
10513	Arbor Spring	1	40299	Arbor Support Brkt. (3/4")	1
10517	Retaining Ring	1	40300	"O" Ring	2
10567	Jamb Nut	1	40301	Thrust Washer	2
10569	Feed Handle	3	40302	Retaining Ring	2
10570	Feed Handle Knob	3	40303	Coolant Fitting	1
10618	Safety Switch Spring	1	40304	Tubing 1/4" O.D.	1
10632	Retaining Ring	1	40309	Cord Clamp	1
10638	Safety Switch Brg. Assy.	1	40312	Roll Pin - Modified	1
10644	Glide Post	1	40326	Cutting Fluid Valve	1
10649	Screw SHC #10-32	3	40332	Inducer Assy.	1
10660	Screw SHC 1/4-20 x 5/8	1	40333	Brass Insert	1
10661	Screw BHC #10-24	2	40338	Nylon Ferrule, 1/4" Tube	1
10725	Carrying Case	1	40377	Shrink Tube	1
10956	Brass Gibs - Pair	1	40388	Magnet Assy 230V	1
10960	Plunger Body	1	40390	Bolt-HH 1/4-20	3
10961	Slide Hammer	1	40398	Ejector Collar Ret. Ring	1
10962	Impactor	1	40417	Coolant Bottle	1
10966	Dust Cap - Plastic	1	40419	Retaining Bracket - Right	1
10967	Microswitch Mount. Spring	1	40420	Retaining bracket - Left	1
10968	Microswitch Adj. Spring	1	40422	Coolant Bottle Clamp	1
10969	Microswitch Mount Screw	1	40424	Anti-Rotational Finger	1
10970	Safety Switch Adj. Brkt.	1	40429	Nut - Locking	1
10971	Screw SHC 1/4-20	2	40433	Coolant Bottle Cap	1
10972	Screw BHC #6-32	2	40442	Cutting Fluid Bottle Assy.	1
10973	#6-32 Nylon Insert Nut	2	40452	Arbor Bolt Kit	1
10974	Retaining Ring, Plunger	1	40464	Ground Strap	1
10975	Pivot Point Seal	1	40465	Screw - HH 1/4-20	1
10977	Screw BH 1/4-20	1	40650	230V Replacement Motor	1
10978	Screw BH 5/16-24	1	50035	Washer 1/4" Internal Tooth	6
10979	Glide Post Lock Screw	1	51042	Screw SHC 1/4-20	2
10983	Safety Switch Ins. Shield	1	90027	Washer Flat	1
10990	Safety Assy. (10909)	1	90028	Washer 1/4" Helical	3
10993	Safety Switch Pivot Assy.	1	90052	Washer Ground Screw	1
40221	Spring Seat	1	90065	Washer 1/4" Star	2
40222	Set Screw - Arbor	2	90352	Screw SHC 1/4-28	4
40223	Ejector Collar	1	90376	Washer #10 Internal	3
40225	Steel Gib	1			
40229	Feed Gear	1			