

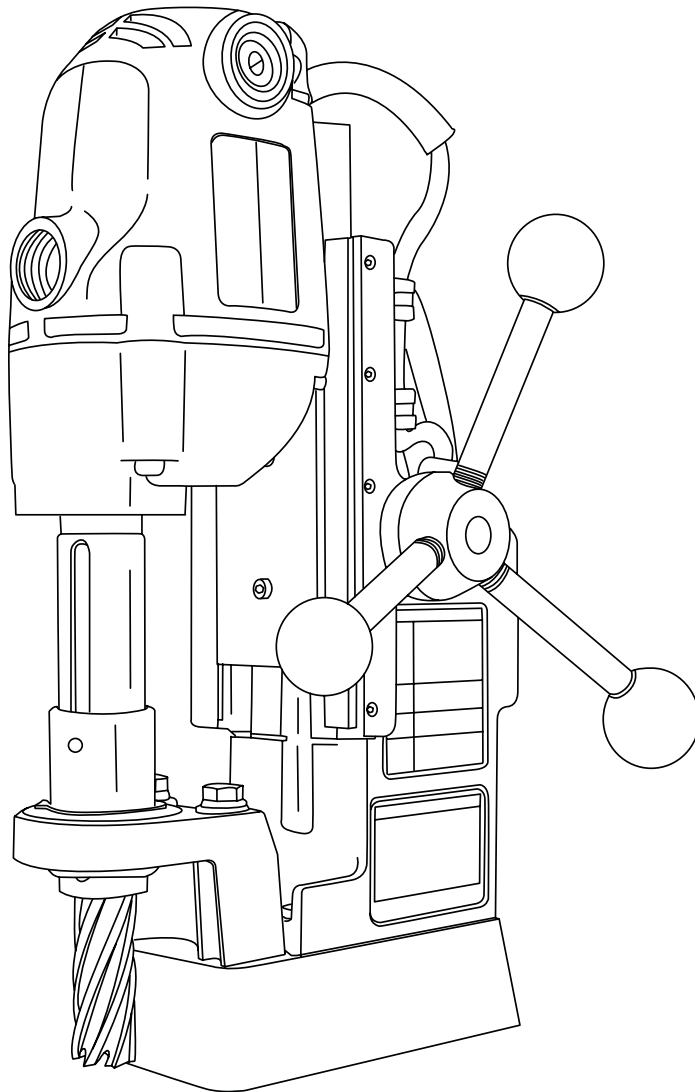

HMD908/HMD908AUS

PORTABLE MAGNETIC DRILLS

OPERATOR'S MANUAL



FOR USE WITH "12,000-SERIES" HOUGEN[®] CUTTERS

INDEX

Page 2	Commercial/Industrial Limited Warranty ...Hougen Patent Notice	Page 8	Motor Parts Diagram
Page 3	Unpacking Your Magnetic Based Drill ...Safety Instructions	Page 9	Motor Parts List
Page 4	Safety Instructions (Cont.)	Page 10	Control Panel Hook Up Diagram
Page 5	Table 1, Table 2	Page 11	Control Panel Parts List
Page 6	...Operation of Controls Operating Instructions	Page 12	Exploded Diagram
Page 7	Installing a Hougen Cutter ...Operation of the Cutting Fluid Reservoir ... Adjustment of Gibs ... Arbor Adjustment	Page 13	Drill Parts List
		Page 14	Maintenance ...Hints for Smoother Operation ...Remedies For Holemaking Problems
		Page 15	"12,000-Series" Cutters ...HMD908 Accessories

COM. / IND. LIMITED WARRANTY

Hougen Manufacturing, Incorporated warrants its Portable Magnetic Drills, Electro-hydraulic Hole Punchers, and Torando II Paint Shaker for one (1) year and its and other products for ninety (90) days from date of purchase against defects due to faulty material or workmanship and will repair or replace (at its option) without charge any items returned. This warranty is void if the item has been damaged by accident or unreasonable use, neglect, improper service, or other causes not arising out of defects in material or workmanship. No other expressed warranty is given or authorized. Hougen Manufacturing, Inc. disclaims any implied warranty of MERCHANTABILITY or FITNESS for any period beyond the expressed warranty and shall not be liable for incidental or consequential damages. Some states do not allow exclusions of incidental or consequential damages or limitation on how long an implied warranty lasts and, if the law of such a state governs your purchase, the above exclusion and limitation may not apply to you. This warranty gives you specific legal rights and you may also have other rights which vary from state to state.

To obtain warranty service, return the item(s), transportation prepaid, to your nearest Factory Authorized Warranty Repair Center or to Hougen Manufacturing, Inc., 3001 Hougen Drive, Swartz Creek, Michigan 48473.

Hougen Drills are warranted against manufacturing defects only. Subject to Hougen Manufacturing inspection.

THIS WARRANTY IS IN LIEU OF ANY OTHER WARRANTY, EXPRESSED OR IMPLIED, INCLUDING ANY WARRANTY OF MERCHANTABILITY OR FITNESS FOR A PARTICULAR PURPOSE.

© 2004 Hougen Manufacturing, Inc.

HOUGEN PATENT NOTICE

The products in this manual may be covered by one or more of the following U.S. patents, foreign patents, and pending patents:

5902076

Photographs and Specifications shown are accurate in detail at time of printing. Manufacturer reserves the right to make improvements and modifications without prior notice.

Hougen, Hougen-Edge, Trak-Star, and Punch-Pro are proprietary trademarks of Hougen Manufacturing, Inc. Ogura and the Ogura logo are proprietary trademarks of Ogura & Co., Ltd. Vac-Pad is a proprietary trademarks of Drillmate PTY, Ltd.

SAFETY FIRST

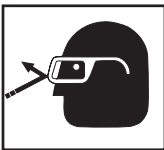

Always wear eye protection while using cutting tools, or in the vicinity of cutting.



CAUTION! Cutters are sharp. Wear gloves when installing or removing cutter from arbor. Do not grab a rotating cutter.



CAUTION! The slug is ejected at the end of the cut. Do not aim cutter or arbor so that ejected slug may hit someone around, or below you.



CAUTION! To prevent electric shock, do not use power tools near wet areas, or where power tool may become wet.

UNPACKING YOUR NEW MAGNETIC DRILL

1. Open shipping carton and remove the literature and hardware packages.
2. **Read and Follow All Instructions** before attempting to operate your new Magnetic Drill.
3. Complete and mail the Product Registration Card [now](#). It is important that Hougen Manufacturing, Inc. have a record of product ownership.
4. Open hardware package and check contents.
 - 10565 1/8" Hex wrench for Gib Adjustment
 - 04558 Feed handles (3)
 - 04532 Feed handle knobs (3)
 - 10506 Set screw for cutter installation (2)
 - 10730 Safety chain
 - 02635 Hex wrench for cutter installation
 - 13013 5/32" Hex wrench for safety switch adjustment
5. Using the handle of Magnetic Drill, lift unit out of the shipping case.
6. Remove all packing and securing material from the drill unit.
7. Screw the three Knobs (04532) into the three Feed Handles (04558) and then screw Handles into the Hub Assembly (40254).
8. Your Magnetic Drill was factory adjusted prior to shipping. Check to make sure that all gib adjustment screws, motor mount screws, front support bracket screws, and magnet mounting screws are snug and have not vibrated loose in transit.
9. Your new Magnetic Drill comes complete with arbor mounted. The 3/4" diameter arbor bore fits all 3/4"-shank "12,000-Series" Hougen Cutters. A 1/2"-diameter bore Arbor Adapter (10851), for mounting 1/2"-shank "12,000-Series" Hougen Cutters, is optional.

Reread Safety Warnings listed in the Operator's Manual and on the drill unit to avoid injury. Follow operating procedures.

IMPORTANT SAFETY INSTRUCTIONS

WARNING: When using electric tools, basic safety precautions should always be followed to reduce the risk of fire, electric shock, and personal injury, including the following:

1. **Read All Instructions**
2. **Grounding Instructions**

This tool should be grounded while in use to protect the operator from electric shock. The tool is equipped with a 3-conductor cord and a 3-prong grounding type lug to fit the proper grounding type receptacle. The green (or green and yellow) conductor in the cord is the grounding wire. Never connect the green (or green and yellow) wire to a live terminal. If your unit is for use on 230V, it has a plug that looks like that shown in sketch (A). If it is for use on 115V, it has a plug that looks like that shown in sketch (D). An adapter, see sketches (B) and (C), is available for connecting 115V type plugs to 2-prong receptacles. The green-colored rigid ear, lug, or the like, extending from the adapter must be connected to a permanent ground, such as a properly grounded outlet box. (See Table 2)
3. **Extension Cords**

Use only 3-wire extension cords that have 3-prong grounding type plugs and 3-pole receptacles that accept the tool's plug. Replace or repair damaged cords. Make sure the conductor size is large enough to prevent excessive voltage drop which will cause loss of power and possible motor damage. (See Table 1)
4. **Consider Work Area Environment**

Do not expose tool to rain. Do not use tool in damp or wet locations. Keep work area well lit. Do not use tool in presence of flammable liquids or gases.
5. **Guard Against Electric Shock**

Prevent body contact with grounded surfaces. For example: pipes, radiators, ranges, refrigerator enclosures.
6. **Keep Children Away**

Do not let visitors contact tool. All visitors should be kept away from work area.
7. **Store Idle Tools**

When not in use, tools should be stored in a dry, land high or locked-up place — out of reach of children.
8. **Use Right Tool**

Do not force small tool or attachment to do the job of a heavy duty tool. Do not use tool for purpose not intended — for example — do not use a circular saw for cutting tree limbs or logs.
9. **Secure Work**

Use clamps or a vise to hold work. It is safer than using your hand and it frees both hands to operate tool.

IMPORTANT SAFETY INSTRUCTIONS (CONT)

- 10. Always Wear Safety Glasses or Goggles**
- 11. Dress Properly**

Do not wear loose clothing or jewelry. They might entangle with spinning chips or get caught in moving parts. Rubber gloves and nonskid footwear are recommended when working outdoors. Wear sturdy leather gloves when working indoors. Wear protective hair covering to contain long hair.
- 12. Do Not Abuse Cord**

Never carry drill unit by its cord or yank it to disconnect from receptacle. Keep cord away from heat, oil, and sharp edges.
- 13. Do Not Overreach**

Keep proper footing and balance at all time.
- 14. Maintain Tools With Care**

Keep tools sharp and clean for better and safer performance. Do not use dull or broken Hougén Cutters. Follow instructions for lubricating and changing accessories. Inspect tool cords periodically and, if damaged, have repaired by authorized service facility. Inspect extension cords periodically and, if damaged, have repaired by authorized service facility. Keep handles dry, clean, and free from oil and grease. Keep handles dry, clean, and free from oil and grease.
- 15. Disconnect Tools**

When not in use, before servicing, and when changing Hougén Cutters or accessories.
- 16. Remove Adjusting Keys and Wrenches**

Form a habit of checking to see that keys and wrenches are removed from tool before turning it on.
- 17. Check Damaged Parts**

Before further use of the drill, a part that is damaged should be carefully checked to determine that it will operate properly and perform its intended function. Check for alignment of moving parts, binding of moving parts, breakage of parts, mounting, and any other conditions that may affect its operation. A part that is damaged should be properly repaired or replaced by an authorized service center unless otherwise indicated elsewhere in this operator manual. Do not operate tool if switch does not turn it on and off.
- 18. Stay Alert**

Watch what you are doing. Use common sense. Do not operate tool when you are tired. Have defective switches replaced by authorized service center.
- 19. Outdoor Use Extension Cords**

When tool is used outdoors, use only extension cords intended for use outdoors and so marked. Refer to **Table 1** for recommended extension cord gauge.
- 20. Additional Safety Precautions**

Arbor and cutter should never be used as a hand hold. Keep hands and clothing away from all moving parts. Do not use Hougén Cutters where ejected slug might cause injury (slug ejected at end of cut). Be sure that all safety devices are properly adjusted and in use. Also, adhere to all operating instructions. Do not drill through any surface that may contain live electrical wiring. Drilling into a live wire could cause exposed metal parts of the drill to be made live. Remove chips wrapped around Hougén Cutter and arbor after each hole. With motor off and power disconnected, grasp chips with leather gloved hand or pliers and pull while rotating counterclockwise. Should the cutter become jammed in the work, stop the unit immediately to prevent personal injury. Disconnect the drill from the power supply and loosen jammed cutter by turning the arbor counterclockwise. Never attempt to free the jammed cutter by starting the motor. If service is required contact your nearest authorized service center.
- 21. Non-Conforming Cutting Tools**

Your Magnetic Drill is designed to use Hougén Cutters. The use of drilling tools having different shank styles is not recommended as they may not tighten securely in the drill arbor with risk of accident or injury.
- 22. Operating Near Welding Equipment**

When operating your Magnetic Drill near an arc welder, it is important that they are connected to the same Earth Ground. If they are not, severe damage to the unit, particularly the power cord, could occur. This could also result in personal injury to the operator.
- 23. Safe Electrical Connection**

Wet electrical connections are shock hazards. To prevent the cutting fluid from traveling along the cord and contacting the plug or power outlet, tie a drip loop as shown. Also elevate extension cords or gang box connections.
- 24. Save These Instructions**

TABLE 1

Length of Cord, Feet	Recommended Wire Gauge	
	115V Motor 10-12 Amps	230V Motor 4-6 Amps
Up to 25	16	18
26-50	14	18
51-100	10	16
101-200	8	14
201-300	6	12
301-500	4	10

TABLE 2

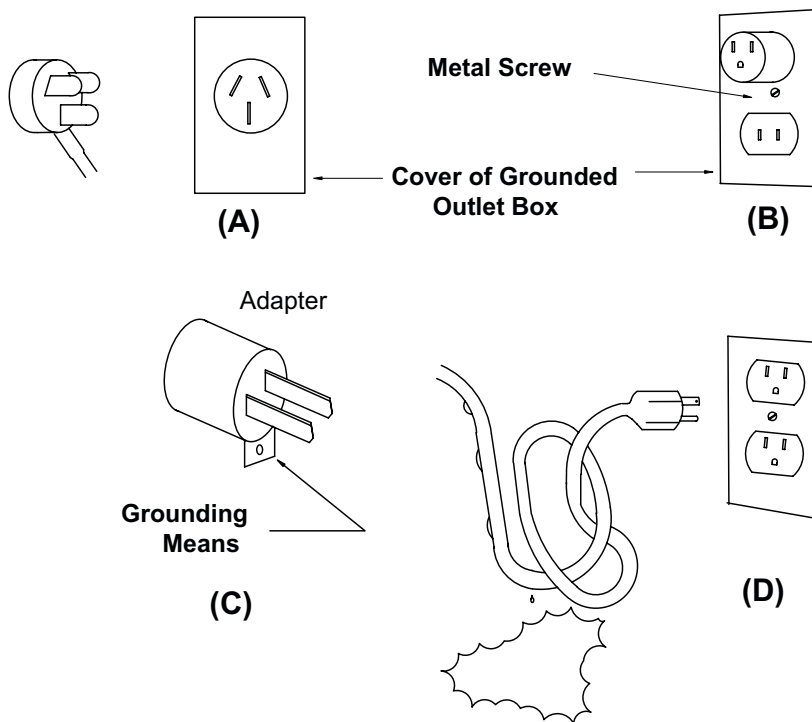

CHECK OUT OPERATION OF CONTROLS BEFORE INSTALLING HOUGEN CUTTER

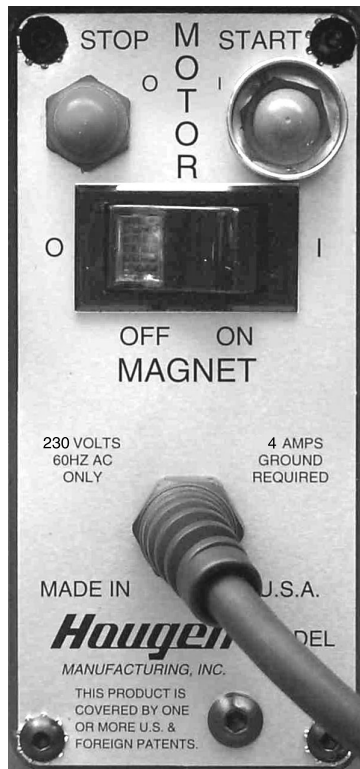

CONTROL PANEL SWITCH PLATE
FIGURE 2

IMPORTANT: Before turning on the machine, it is important that the operator understands the interrelated functions of the **SAFETY SWITCH, MAGNET SWITCHES, AND MOTOR SWITCHES.**

SAFETY SWITCH — Located in base of drill. Enables motor operation only when magnet is properly seated on a clean and flat work surface. Turns motor off if drill is lifted off work surface.

MAGNET ON SWITCH — Energizes the magnetic base and activates the safety switch. Motor can now be started by pushing the motor **START** switch.

MAGNET OFF SWITCH — De-energizes the magnetic base and deactivates motor **START** switch. (Note: Magnet **OFF** switch will not function while motor is on.)

MOTOR START SWITCH — Starts the motor (will not function unless the magnetic base is energized and the safety switch is activated).

MOTOR STOP SWITCH — Deactivates motor. Magnetic base remains energized and safety switch activated.

1. Place Magnetic Drill on clean, flat steel plate that is at least 3/8" thick.
2. Plug unit into proper AC power source. **DO NOT use with DC Power**
3. Locate the Magnet **ON** and **OFF** switches and the motor **STOP** and **START** switches (Fig. 2).
4. **NOTE: A loss of power will de-energize the magnetic base and deactivate the motor. When power is restored, the magnet will reenergize, however, the motor START switch must be depressed before the motor will start.**

OPERATING INSTRUCTIONS

Always remember that the magnet's holding power is directly related to the workpiece thickness and surface condition. (Rating of 748 Kg pull is based on test using a 25mm thick ground surface.) Since magnetic attraction diminishes with thinner material or rough surfaces, mechanical clamping of drill unit to the workpiece should be used when cutting thin material (9.5mm or less) or material with uneven surfaces.

1. Make sure workpiece and bottom of magnet are free of chips, oil, etc.
2. Position drill by sliding it and gently feeding Arbor so that pilot point is touching center of hole to be drilled.
3. Secure unit to workpiece with safety chain.
4. Turn magnet ON by pressing the magnet ON button.
5. Turn Feed Handle, raising the cutter until the pilot is above the work surface.
6. Make certain that cutter is clear of workpiece and turn motor ON by pressing the motor START button.
7. Feed Hougen Cutter slowly into workpiece. Only after cutting path is established to a depth of about 1/16" can full force be applied to feed handles.
8. Ease up on feed pressure as cutter starts breaking through.
9. At conclusion of cut, turn motor OFF by pressing motor STOP button. Turn Feed Handles to raise Arbor thereby ejecting the slug if it hasn't already fallen free.
10. Turn magnet OFF by pressing the magnet OFF button. As the magnet de-energizes, the rear of the magnet should lift up off the work surface.
11. **Disconnect from power source.**
12. If necessary, remove chips from cutter and magnet, preferably wearing leather work gloves and/or with pliers. Disconnect safety chain and you are ready to move unit to new drilling position.

INSTALLING HOUGEN CUTTER IN ARBOR

1. Disconnect from power source.
2. Lay drill on its side with feed handles up or be sure Arbor clears table if unit is in normal operating position.
3. Turn Feed Handles until cutter mounting set screws are exposed and completely remove the set screw.
4. Insert proper pilot in shank end of Hougen Cutter.
5. Insert Hougen Cutter until flat on cutter shank is aligned with set screw holes and is exactly perpendicular to axis of set screw holes. If 1/2" diameter shank cutter is used, slip (10851) Arbor Adapter over the cutter shank with adapter hole positioned exactly over flat on cutter shank prior to inserting into Arbor bore.
6. Insert set screws and tighten. When mounting 1/2" diameter shank cutter with adapter, use longer set screw. (ordered separately) Check to be certain that cutter is secure.

OPERATION OF CUTTING FLUID RESERVOIR

1. With Magnetic Drill in operating position, turn the feed handles so that cutter and pilot are above the work surface.
2. With magnet turned ON and motor OFF, fill reservoir by introducing cutting fluid through slots in Arbor.
Cutting fluid should not leak out.
3. Test metering capabilities of Arbor/Cutter/Pilot assembly (magnet ON-motor OFF) by feeding the Arbor gently toward work surface until pilot is pushed up into Cutter, thus allowing fluid to filter down onto work surface through groove in pilot.
4. For proper lubrication, all cutting fluid in reservoir should empty onto work surface in no less than 15 seconds and no longer than 30 seconds

ADJUSTMENT OF GIBS

1. Loosen all Gib Screws (40237).
2. Feed the drill in and out a few times and then, with top of motor slide flush with top of housing, tighten the Gib Screws until you feel them touch the Steel Gib (02431).
3. Feed the drill in and out again.
4. Adjust Gib Screws so that there is uniform pressure from top to bottom. (Top of motor slide flush with top of housing.)
5. Turn each Gib Screw in about 1/8 to 1/4 turn, depending upon your preference.
6. Gibs should be tight enough so that slide moves up and down smoothly with no wobble or shaking. (Looseness will cause cutter breakage.)

NOTE: Gibs should be lubricated regularly.

ARBOR ADJUSTMENT

Adjust Gibs before adjusting front support bracket.

1. Loosen Arbor Support Bracket Bolts.
2. Be sure top of arbor is flush with the shoulder on motor output shaft. Also make certain arbor is securely fastened.
3. Turn feed handle until motor and spindle are at the bottom of their travel.
4. Tighten Arbor Support Bolts.
5. Feed slide up and down a few times, checking for free and uniform movement.

NOTE: Check Arbor support bolts regularly to make certain they are tight. Tighten as required.

MOTOR PARTS DIAGRAM

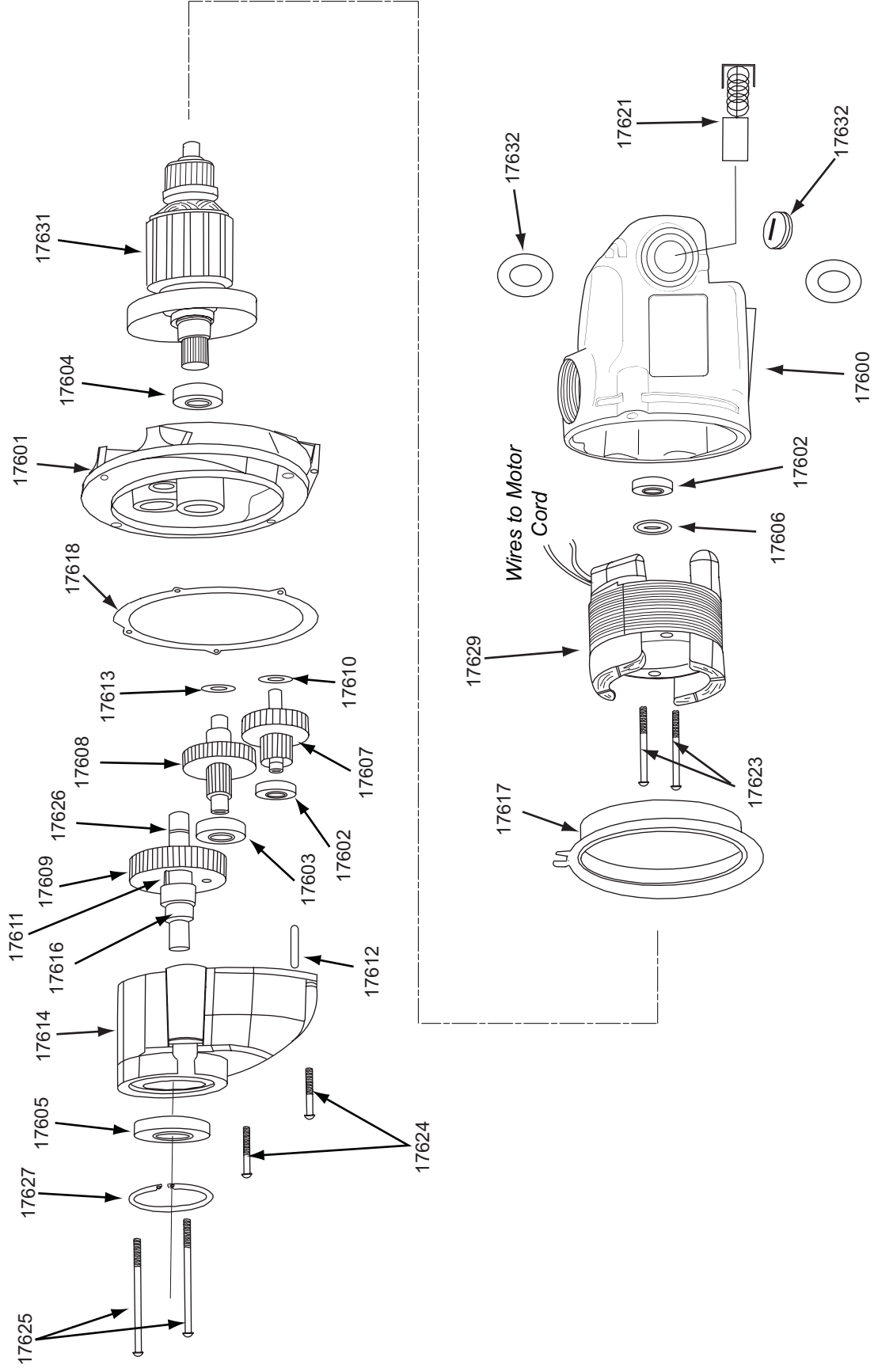

MOTOR PARTS LISTING

Part No.	Description	Qty. Req'd.	Part No.	Description	Qty. Req'd.
04499	Motor, Replac. Assy.		17614	Gear Housing	1
17600	Field Case	1	17616	Spindle	1
17601	Gear Housing Cover	1	17617	Fan Guide	1
17602	Ball Bearing	2	17618	Gasket	1
17603	Ball Bearing	1	17621	Carbon Brush	2
17604	Ball Bearing	1	17622	Brush Cap	2
17605	Ball Bearing	1	17623	Pan Head Screw (Field)	2
17606	Dust Seal	1	17624	Pan Head Screw (Short)	2
17607	1st. Inter Gear Assy	1	17625	Pan Head Screw (Long)	2
17608	2nd. Inter Gear Assy	1	17626	Retaining Ring	1
17609	Spur Gear	1	17627	Retaining Ring	1
17610	Flat Washer	1	17629	Field	1
17611	Key	1	17631	Armature	2
17612	Dowel Pin	1	17632	Paper Washer	2
17613	Flat Washer	1			

CONTROL PANEL HOOK UP DIAGRAM

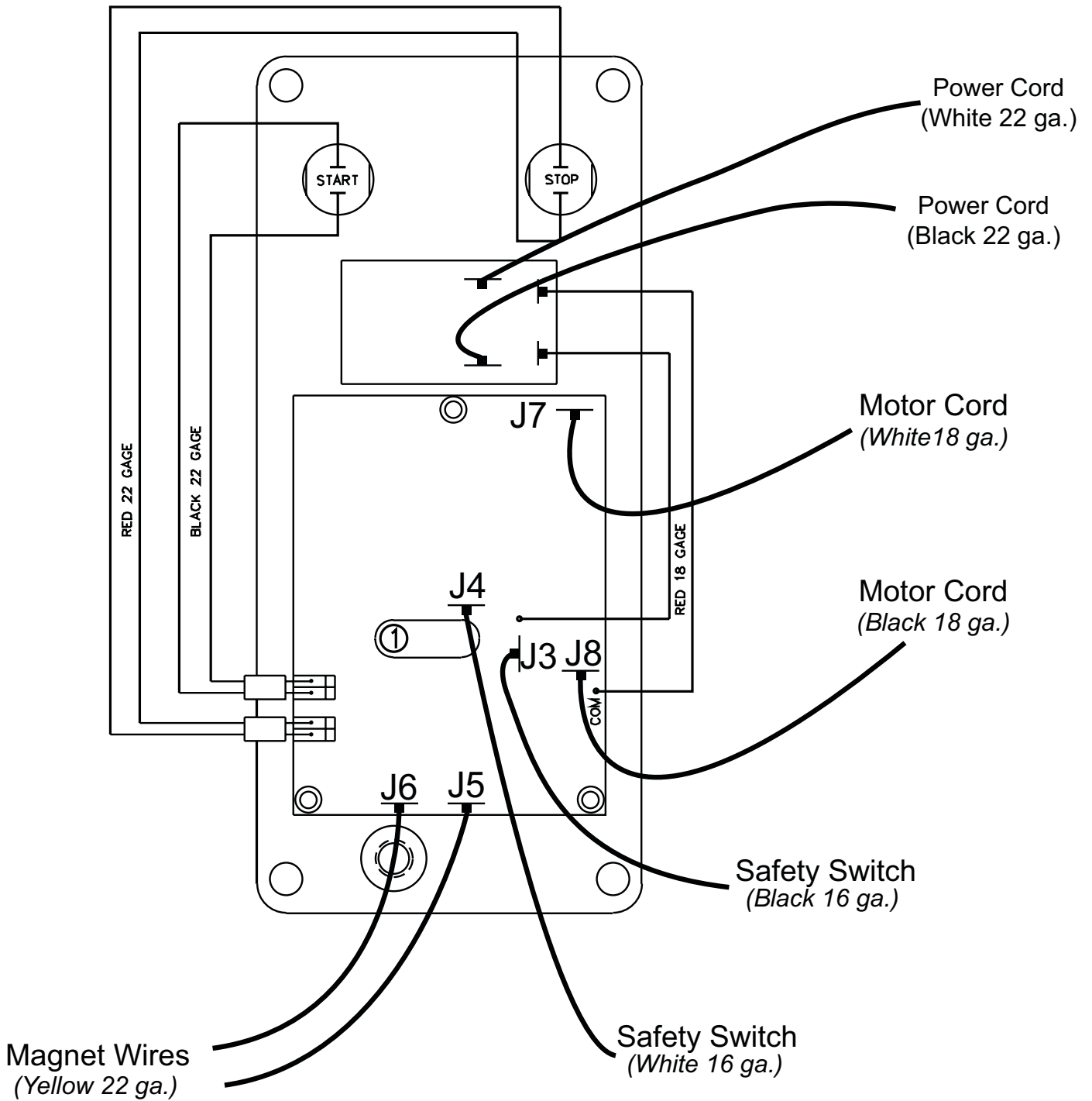

CONTROL PANEL PARTS LIST

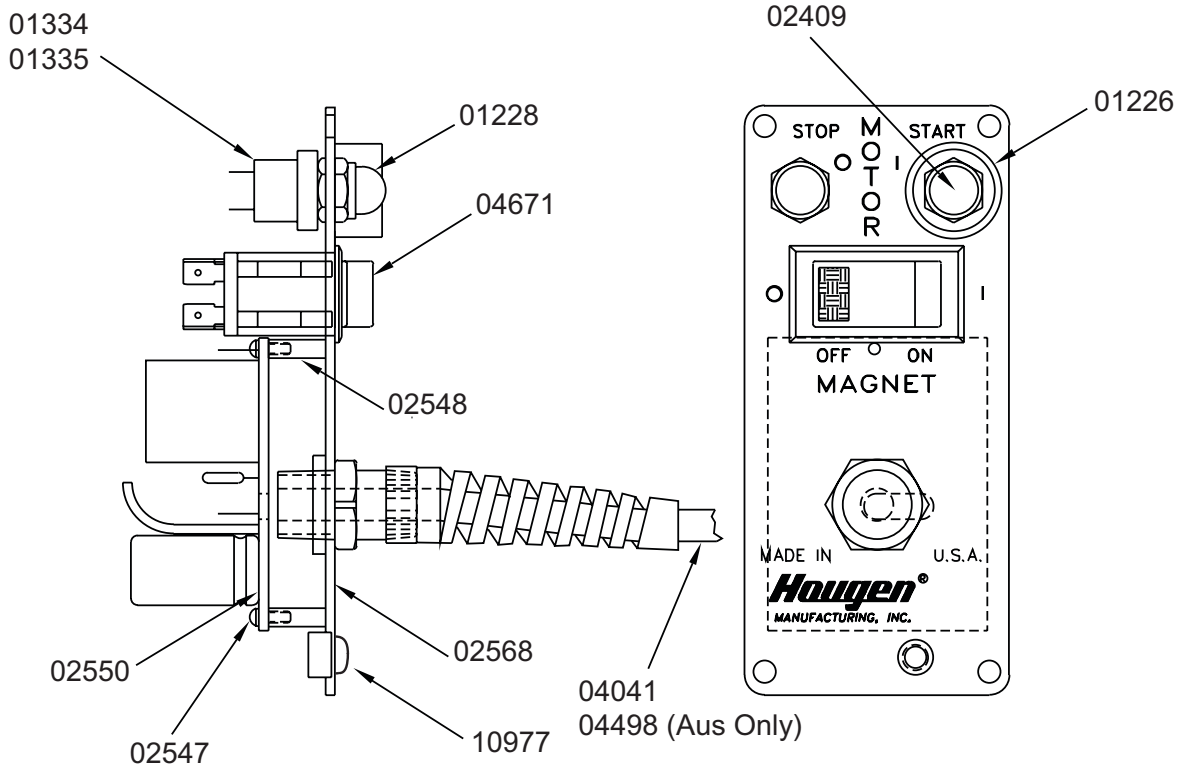

PART #	DESCRIPTION	QTY.
02568	FACEPLATE	1
04041	POWER CORD ASSY.	1
04498	POWER CORD ASSY. (Aus Model Only)	1
02409	SEAL SWITCH GREEN	1
01226	PUSHBUTTON GUARD	1
04671	ROCKER SWITCH	1
01228	SEAL SWITCH RED	1
01335	SWITCH ASSY. OFF/STOP	1
01334	SWITCH ASSY. ON/START	1
02550	CIRCUIT BOARD ASSY.	1
02548	SPACER	3
02547	SCREW #4-40	3
10977	SCREW, BH 1/4-20	1

MODEL HMD908 EXPLODED DIAGRAM

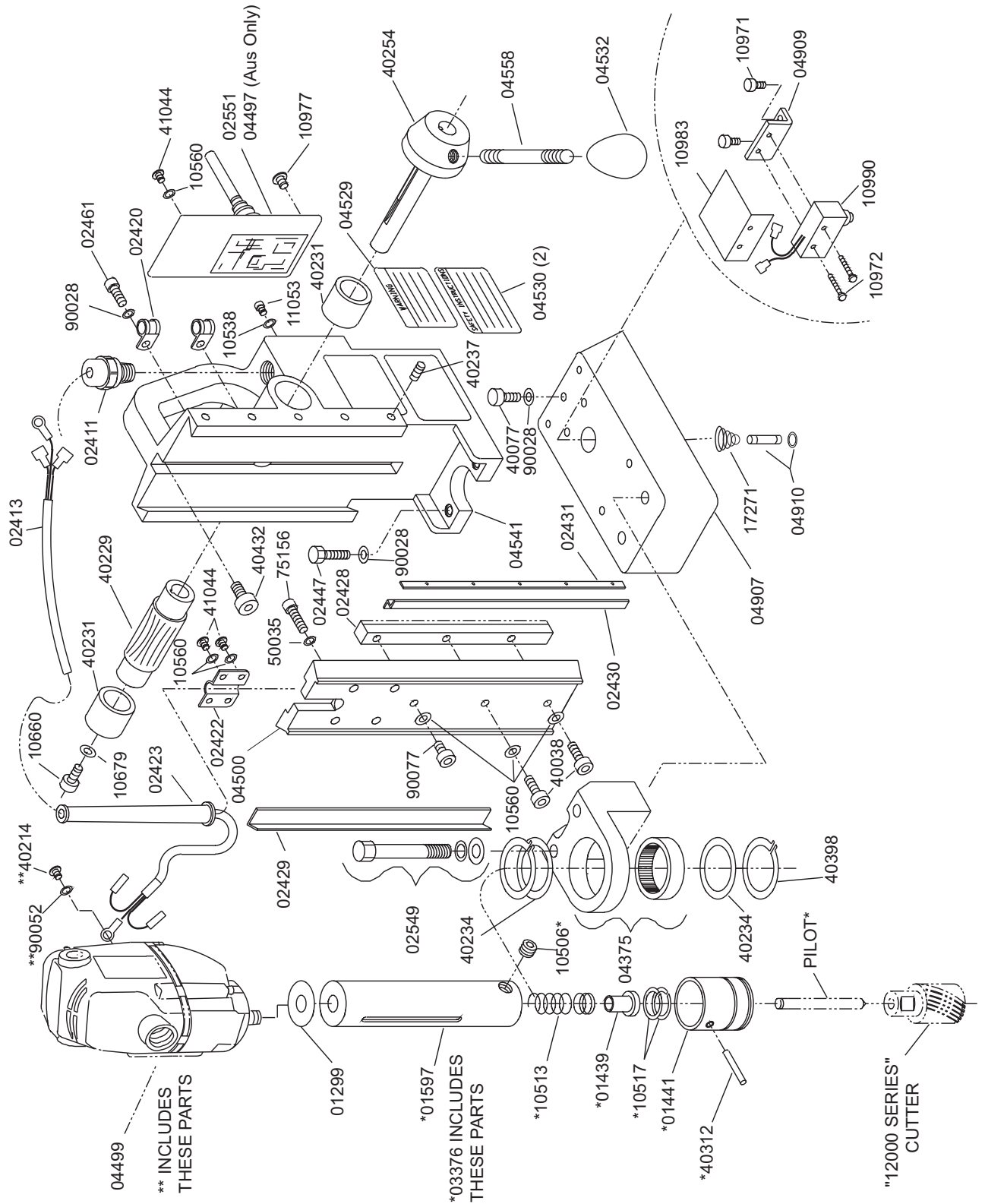

DRILL PARTS LIST

PART NO.	DESCRIPTION	QTY. REQ'D.
01299	WASHER, THRUST	1
01439	1/4-28 X 1/2 SHC SCREW	1
01441	EJECTOR COLLAR	1
01597	ARBOR BODY	1
02411	STRAIN RELIEF - MTR. CORD	1
02413	MOTOR CORD ASSEMBLY	1
02420	MOTOR CORD CLAMP	2
02422	MOTOR CORD BRACKET	1
02423	MOTOR CORD FLEX PROTE.	1
02428	RACK GEAR	1
02429	BRASS GIB - RIGHT	1
02430	BRASS GIB - LEFT	1
02431	STEEL GIB	1
02447	BOLT-HEX HEAD 1/4-28	2
02461	1/4-20 X 3/8 BHC SCREW	2
02549	3/8" BOLT KIT	1
02551	CONTROL PANEL (HMD908)	
03376	ARBOR ASSY	1
03857	SCREW-HEX HEAD #4-40	16
04375	FRONT SUPP. BRKT. ASSY.	1
04497	CONTROL PANEL (AUS ONLY)	1
04499	230V MOTOR REPLAC.	1
04500	SLIDE, MOTOR MOUNT	1
04529	WARNING TAG	1
04530	SAFETY TAG	2
04532	FEED HANDLE KNOB	3
04541	HOUSING ASSEMBLY	1
04558	FEED HANDLE	3
04907	MAGNET	1
04909	BRACKET SAFETY SWITCH	1
04910	PLUNGER ASSEMBLY	1
10506	3/8-24 X .305 SS SCREW	2

PART NO.	DESCRIPTION	QTY. REQ'D.
10513	ARBOR SPRING	1
10517	RETAINING RING	2
10538	LOCK WASHER	1
10560	LOCKWASHER #10 EXT.	11
10660	1/4-20 X 5/8 SHC SCREW	1
10971	SCREW, SHC 1/4-20 X 1/2	2
10972	SCREW, BHC #6-32 X 7/8	2
10977	SCREW, BHC 1/4-20 X 1/4	1
10679	1/4" FLAT WASHER	1
10983	S/S SHIELD	1
10990	S/S ASSEMBLY	1
11053	SCREW, BHC #8-32	1
17271	SPRING	1
40038	SCREW, SHC #10-32 X 5/8	2
40077	SCREW, SHC 1/4-20 X 1"	1
40214	SCREW. SHC #6-32 X 1/2	1
40229	FEED GEAR	1
40231	BRONZE BUSHING	2
40234	THRUST WASHER	2
40237	GIB SCREW	5
40254	HUB ASSEMBLY	1
40312	ROLL PIN ALTERED	1
40398	RETAINING RING	1
40432	SCREW, SHC 1/4-28 X 3/8	1
41044	SCREW, BHC #10-32 X 3/8	6
50035	LOCKWASHER 1/4 EXT	4
75156	SCREW, SHC M6 X 15MM	4
90028	LOCKWASHER 1/4 HELI.	5
90052	LOCKWASHER #6 EXT.	1
90077	SCREW BHC #10-32 X 1/2	1

MAINTENANCE

In order to minimize wear on moving parts and to insure smoother operation and longer life for your magnetic drill, the following maintenance should be done periodically, based on use

1. Regularly tighten all fasteners and replace all worn parts.
2. Check motor brushes and replace if worn. (Break in period - 30 minutes at no load speed)
3. Check power cord and cord from panel to motor and, if cracked or frayed, return to an authorized repair center for replacement.
4. Apply grease to the slide dovetails, brass gibs, and the feed gear rack. For best results use Shell Cyprina-RA or equivalent.
5. Remove arbor and pack the bearing in the front support bracket with grease. Use Shell Cyprina-RA or equivalent.

HINTS FOR SMOOTHER OPERATION

1. Keep insides of Hougén Cutter clear of chips. Chips will interfere with cutting to maximum depth, may impede the free oil flow and can cause cutter breakage.
2. Keep work, machine, arbor and Hougén Cutter free of chips and dirt.
3. Tighten all bolts and fasteners regularly.
4. We highly recommend using a light viscosity cutting fluid (preferably Hougén Cutting Fluid)
5. Occasionally check metering of cutting fluid flow. Lack of cutting fluid may cause Hougén Cutter to freeze in cut, slug to stick and may result in poor cutter life.
6. Always start cut with light feed pressure and then increase sufficiently to achieve maximum cutting rate.
7. Ease off on pressure as cutter begins to break through at the end of the cut.
8. Keep slide dovetails, brass gibs and feed rack lubricated and free of chips and dirt.
9. When slug hangs up in cutter, bring cutter down on a flat surface. This will normally straighten a cocked slug, allowing it to be ejected.
10. When cutting large diameter or deep holes it may be necessary to stop in the middle of the cut to add cutting fluid and remove the chips from around the arbor. (When doing this DO NOT raise the cutter out of the hole. Doing so can allow chips to get under the teeth of the cutter and make it difficult to restart the cut.)

#1 cause of cutter breakage and prematurely dull teeth is too little feed pressure

REMEDIES FOR HOLEMaking PROBLEMS

1. **Trouble: Magnetic base won't hold effectively to work.**
 - a. Cause: Chips or dirt under magnet.
Remedy: Clear area of chips and dirt.
 - b. Cause: Irregular surface on bottom of magnet or on workpiece.
Remedy: Lightly surface grind the bottom of the magnet flat and/or file imperfections flat on the work surface as needed.
2. **Trouble: Cutter tends to move across surface of work.**
 - a. Cause: Magnetic base not holding effectively.
Remedy: See causes and remedies under No. 1 above.
 - b. Cause: Too much feed pressure at start of cut.
Remedy: Light pressure until a groove is cut. The groove then serves as a stabilizer.
 - c. Cause: Worn pilot.
Remedy: Replace pilot
3. **Trouble: Out of round holes.**
 - a. Cause: Worn arbor support bracket bearing and or ejector collar.
Remedy: Replace: (only a few thousandths wear permissible.)
 - b. Cause: Misaligned support bracket
Remedy: Realign support bracket
4. **Trouble: Motor and slide won't stay in set position**
 - a. Cause: Gibs too loose
Remedy: Adjust gibs
5. **Trouble: Erratic or intermittent feed.**
 - a. Cause: Worn or pinion and/or rack.
Remedy: Replace worn parts.
6. **Trouble: Motor doesn't run when motor START button is pushed.**
 - a. Cause: Magnet is not turned on.
Remedy: Push magnet ON button.
 - b. Cause: Magnet on rough or dirty work surface and safety switch not fully depressed.
Remedy: File work surface flat and clean all chips and oil from under magnet.
 - c. Cause: No power.
Remedy: Check power source and extension cords.
 - d. Cause: Worn motor brushes.
Remedy: Replace brushes.
 - e. Cause: Faulty motor START switch.
Remedy: Return unit to an authorized repair center to have switch replaced.

NOTE: If you are unable to correct any malfunction after trying the above, do not attempt to operate the drill. Return the unit to the factory or authorized Repair Center for service.

“12,000-SERIES”

Diameter (In & mm)	Decimal Equivalent	1" - 25.4MM DOC PART NO.	2" - 50.8MM DOC PART NO.
PILOTS >>>		10531	10532
7/16	.4375	12114	12214
12MM	.4724	12312	12412
PILOTS >>		10533	10534
1/2	.5000	12116	12216
9/16	.5625	12118	12218
5/8	.6250	12120	12220
11/16	.6875	12122	12222
13MM	.5118	12313	12413
14MM	.5512	12314	12414
15MM	.5906	12315	12415
16MM	.6299	12316	12416
17MM	.6693	12317	12417
18MM	.7087	12318	12418
PILOTS>>		10527	10528
19MM	.7480	12319	12419
3/4	.7500	12124	12224
20MM	.7874	12320	12420
13/16	.8125	12126	12226
21MM	.8268	12321	12421
22MM	.8661	12322	12422
7/8	.8750	12128	12228
23MM	.9055	12323	12423
15/16	.9375	12130	12230
24MM	.9449	12324	12424
25MM	.9843	12325	12425
1	1.0000	12132	12232
26MM	1.0237	12326	12426
1-1/16	1.0625	12134	12234
27MM	1.0630	12327	12427
28MM	1.1020	12328	12428
1-1/8	1.1250	12136	12236
29MM	1.1417	12329	12429
30MM	1.1812	12330	12430
1-3/16	1.1875	12138	12238
31MM	1.2205	12140	12240
1-1/4	1.2500	12140	12240
32MM	1.2598	12332	12432
33MM	1.2993	12333	12433
1-5/16	1.3125	12142	12242
34MM	1.3386	12334	12434
1-3/8	1.3750	12144	12244
35MM	1.3779	12335	12435
36MM	1.4173	12337	12437
1-7/16	1.4375	12146	12246
37MM	1.4567	12337	12437
38MM	1.4961	---	12438
1-1/2	1.5000	12148	12248

HMD908 ACCESSORIES

Part No.	Description
01829	Spindle-Adapter for Jacobs Chuck
02449	Ratchet Drive
02463	Tapping Kit #6 through 1/2"
02564	Chain Mount Pipe Adapter Kit
02608	Twist Drill Adapter
03845	Twist Drill Adapter Kit Includes 5 Twist Drills with flatted shanks
05000	Portable Vac Pad
10100	1" Arbor Extender
10200	2" Arbor Extender
10732	1/2" Jacobs Chuck (Requires 01829)
12958	Counter Sink Kit
12001	Cutter Kit 1" Depth of Cut Sizes 9/16, 11/16, 13/16, 15/16, 1-1/16
12002	Cutter Kit 2" Depth of Cut Sizes 9/16, 11/16, 13/16, 15/16, 1-1/16
12003	Cutter Kit 25mm Depth Of Cut Sizes 14mm, 16mm, 18mm, 20mm, 22mm
12004	Cutter Kit 50mm Depth of Cut Sizes 14mm, 16mm, 18mm, 20mm, 22mm