

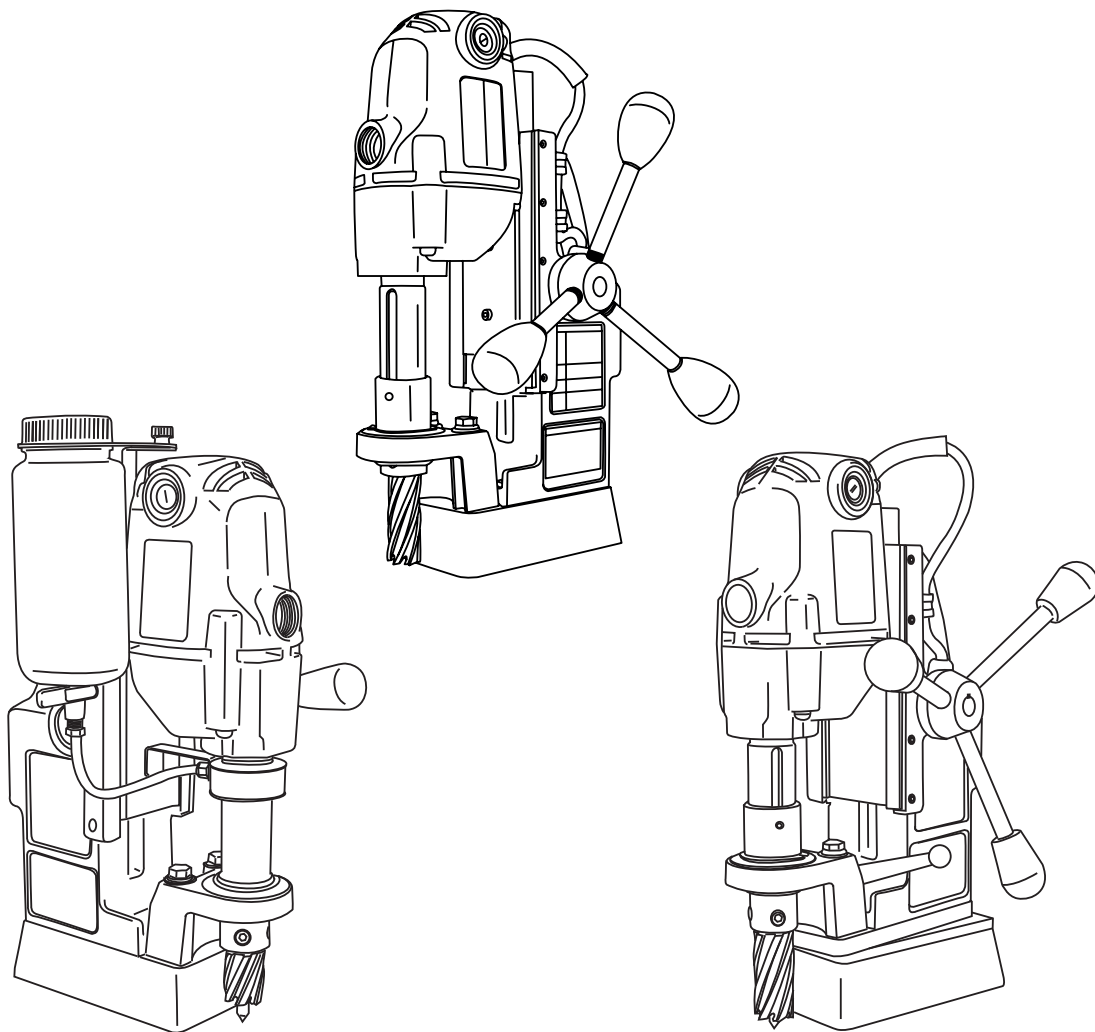

# HMD904 SERIES PORTABLE MAGNETIC DRILL

## OPERATOR'S MANUAL

COVERS DRILL PART NUMBER 0904301, 0904302, 0904303, 0904304,  
0904401, 0904402, 0904403 AND 0904404



FOR USE WITH HOUGEN<sup>®</sup> ROTABROACH<sup>®</sup> CUTTERS



# Important Safety Instructions



**WARNING:** Read and understand all instructions. Failure to follow all instructions listed below, may result in electrical shock, fire and/or serious personal injury.

## Work Area

**Keep your work area clean and well lit.** Cluttered benches and dark areas invite accidents.

**Do not operate power tools in explosive atmospheres, such as in the presence of flammable liquids, gases or dust.** Power tools create sparks which may ignite the dust or fumes.

**Keep bystanders, children, and visitors away while operating a power tool.** Distractions can cause you to lose control.

## Electrical Safety

**Grounded tools must be plugged into an outlet properly installed and grounded in accordance with all codes and ordinances. Never remove the ground prong or modify the plug in any way. Do not use any adapter plugs. Check with a qualified electrician if you are in doubt as to whether the outlet is properly grounded.** If the tools should electrically malfunction or break-down, grounding provides a low resistance path to carry electricity away from the user.

**Avoid body contact with grounded surfaces such as pipes, radiators, ranges and refrigerators.** There is an increased risk of electric shock if your body is grounded.

**Don't expose power tools to rain or wet conditions.** Water entering a power tool will increase the risk of electric shock.

**Do not abuse the cord. Never use the cord to carry the tools or pull the plug from an outlet. Keep cord away from heat, oil, sharp edges or moving parts. Replace damaged cords immediately.** Damaged cords increase the risk of electric shock.

**When operating a power tool outside, use an outdoor extension cord marked "W-A" or "W";** These cords are rated for outdoor use and reduce the risk of electrical shock.

## Personal Safety

**Stay alert, watch what you are doing and use common sense when using a power tool. Do not use tool while tired or under the influence of drugs, alcohol, or medication.** A moment of inattention while operating power tools may result in serious personal injury.

**Dress properly. Do not wear loose clothing or jewelry. Contain long hair. Keep your hair, clothing, and gloves away from moving parts.** Loose clothes, jewelry, or long hair can be caught in moving parts.

**Avoid accidental starting. Be sure switch is off before plugging in.** Carrying tools with your finger on the switch or plugging in tools that have the switch on invites accidents.

**Remove adjusting keys or switches before turning the tool on.** A wrench or a key that is left attached to a rotating part of the tool may result in personal injury.

**Do not overreach. Keep proper footing and balance at all times.** Proper footing and balance enables better control of the tool in unexpected situations.

**Use safety equipment. Always wear eye protection.** Dust mask, non-skid safety shoes, hard hat, or hearing protection must be used for appropriate conditions.

**Always use safety chain.** Mounting can release.

## Tool Use and Care

**Use clamps or other practical way to secure and support the work piece to a stable platform.** Holding the work by hand or against your body is unstable and may lead to loss of control.

**Do not force tool. Use the correct tool for your application.** The correct tool will do the job better and safer at the rate for which it is designed.

**Do not use tool if switch does not turn it on or off.** Any tool that cannot be controlled with the switch is dangerous and must be repaired.

**Disconnect the plug from the power source before making any adjustments, changing accessories, or storing the tool.** Such preventive safety measures reduce the risk of starting the tool accidentally.

**Store idle tools out of reach of children and other untrained persons.** Tools are dangerous in the hands of untrained users.

**Maintain tools with care. Keep cutting tools sharp and clean.** Properly maintained tools, with sharp cutting edges are less likely to bind and are easier to control.

**Check for misalignment or binding of moving parts, breakage of parts, and any other condition that may affect the tools operation. If damaged, have the tool serviced before using.** Many accidents are caused by poorly maintained tools.

**Use only accessories that are recommended by the manufacturer for your model.** Accessories that may be suitable for one tool, may become hazardous when used on another tool.

## Service

**Tool service must be performed only by qualified repair personnel.** Service or maintenance performed by unqualified personnel could result in a risk of injury.

**When servicing a tool, use only identical replacement parts. Follow instructions in the Maintenance section of this manual.** Use of unauthorized parts or failure to follow Maintenance Instructions may create a risk of electric shock or injury.

# Important Safety Instructions - Continued



**WARNING:** Read and understand all instructions. Failure to follow all instructions listed below, may result in electrical shock, fire and/or serious personal injury.

## Safe Electrical Connection

Your Mag Drill is rated for use on 115VAC or 230V at 50-60Hz. Do not attempt to use drill on power sources rated other than this.

## Plugs and Receptacles

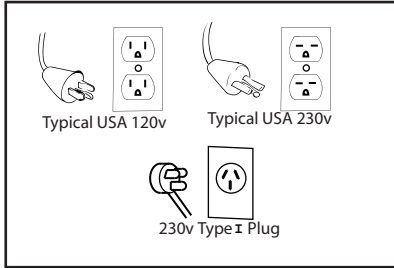

Wet electrical connections are shock hazards. To prevent the cutting fluid from traveling along the cord and contacting the plug or power outlet, tie a drip loop as shown. Also elevate extension cords or gang box connections.



## Extension Cords

Use only 3-wire extension cords that have 3-prong grounding type plugs and 3-pole receptacles that accept the tool's plug. Replace or repair damaged cords. Make sure the conductor size is large enough to prevent excessive voltage drop which will cause loss of power and possible motor damage.

## Extension Cord Table

LENGTH OF CORD, FEET	RECOMMENDED WIRE GAUGE	
	115V MOTOR 10 - 12 AMPS	230 V MOTOR 5 - 6 AMPS
UP TO 25	16	18
26 - 50	14	18
51 - 100	10	16
101 - 200	8	14
201 - 300	6	12
301 - 500	4	10

## Outdoor Use Extension Cords

When tool is used outdoors, use only extension cords intended for use outdoors and so marked.

## Additional Safety Precautions

Arbor and cutter should never be used as a hand-hold. Keep hands and clothing away from all moving parts. Do not use Hougen Cutters where ejected slug might cause injury (slug ejected at end of cut). Also, adhere to all operating instructions. Do not drill through any surface that may contain live electrical wiring. Drilling into a live wire could cause exposed

metal parts of the drill to be made live. Remove chips wrapped around Cutter and arbor after each hole. With motor off and power disconnected, grasp chips with leather gloved hand or pliers and pull while rotating counterclockwise. Should the cutter become jammed in the work, stop the unit immediately to prevent personal injury. Disconnect the drill from the power supply and loosen jammed cutter by turning the arbor counterclockwise. Never attempt to free the jammed cutter by starting the motor. Service at authorized repair center only. product warranty.

## Operating Near Welding Equipment

DO NOT operate this unit on the same work surface that welding is being performed on. Severe damage to the unit, particularly the power cord, could occur. This could also result in personal injury to the operator.

## Circuit Breaker (If Applicable)

Changing of the circuit breaker to a higher amp rated breaker, or bypassing the circuit breaker is not recommended and will void

## Circuit Breaker Operation (If Applicable)

The circuit breaker is a thermal breaker. When it reaches the higher temperature rating it will trip and cause the unit to shut down. This is a protective device and can be reset after 5 to 10. To reset the breaker, press the breaker button back in. If it does not reset, let the unit cool a little longer until you can push the button in and it stays in position.

Save these Instructions.

## SAFETY SWITCH INDICATOR LIGHT

The Safety Switch Indicator Light is a Standard Safety Feature on HMD904 magnetic drills. Its purpose is to inform the user that an unsafe condition exists.

### If light is Green:

In normal operation the safety switch light will be green. Motor "On" and "Off" Switches function normally.

### If light is Red:

A condition with the safety switch exists that needs to be corrected.

Possible causes:

- Safety Switch is defective. Have drill serviced.
- Uneven work surface or material. Check work surface for flatness.
- Dirt or chips under magnet. Clean work surface.

Material should be a least 3/8" thick. Material thinner than 3/8" will cause a "weak" magnet condition.

**HOUGEN MANUFACTURING RECOMMENDS THAT CONDITIONS ARE CORRECTED SO LIGHT TURNS GREEN. THIS ALLOWS FOR THE UNIT TO BE OPERATED IN A SAFE MANNER.**

For any questions please contact Hougen Manufacturing's Technical Service at (810) 635-7111.

## Commercial / Industrial Limited Warranty

Hougen Manufacturing, Incorporated warrants its Portable Magnetic Drills and its Electro-hydraulic Hole Punchers for a period of 1 year and other products for ninety (90) days from date of purchase against defects due to faulty material or workmanship and will repair or replace (at its option) without charge any items returned. This warranty is void if the item has been damaged by accident or unreasonable use, neglect, improper service, or other causes not arising out of defects in material or workmanship. No other expressed warranty is given or authorized. Hougen Manufacturing, Inc. disclaims any implied warranty of MERCHANTABILITY or FITNESS for any period beyond the expressed warranty and shall not be liable for incidental or consequential damages. Some states do not allow exclusions of incidental or consequential damages or limitation on how long an implied warranty lasts and, if the law of such a state governs your purchase, the above exclusion and limitation may not apply to you. This warranty gives you specific legal rights and you may also have other rights which vary from state to state.

To obtain warranty service, return the item(s), transportation prepaid, to your nearest Factory Authorized Warranty Repair Center or to Hougen Manufacturing, Inc., 3001 Hougen Drive, Swartz Creek, Michigan 48473.

Hougen Drills are warranted against manufacturing defects only. Subject to Hougen Manufacturing inspection.

THIS WARRANTY IS IN LIEU OF ANY OTHER WARRANTY, EXPRESSED OR IMPLIED, INCLUDING ANY WARRANTY OF MERCHANTABILITY OR FITNESS FOR A PARTICULAR PURPOSE.

© 2013 Hougen Manufacturing, Inc.

Photographs and Specifications shown are accurate in detail at time of printing. Manufacturer reserves the right to make improvements and modifications without prior notice.

Hougen, Rotabroach, and Hougen-Edge are proprietary trademarks of Hougen Manufacturing Inc.

## UNPACKING YOUR NEW MAGNETIC DRILL

1. Open shipping carton and remove the literature and hardware packages.
2. **Read and Follow All Instructions** before attempting to operate your new Magnetic Drill.
3. Complete and mail the Product Registration Card now. It is important that Hougen Manufacturing, Inc. have a record of product ownership.
4. Open hardware package and check contents.
  - 10565 1/8" Hex wrench for Gib Adjustment
  - 04558 Feed handles (3)
  - 04532 Feed handle knobs (3)
  - 10506 Set screw for cutter installation (2)
  - 10730 Safety chain
  - 02635 Hex wrench for cutter installation
  - 13013 5/32" Hex wrench
5. Using the handle of Magnetic Drill, lift unit out of the shipping case.
6. Remove all packing and securing material from the drill unit.
7. Screw the three Knobs (04532) into the three Feed Handles (04558) and then screw Handles into the Hub Assembly (40254). Do not overtighten or may strip the knobs.
8. Your Magnetic Drill was factory adjusted prior to shipping. Check to make sure that all gib adjustment screws, motor mount screws, front support bracket screws, and magnet mounting screws are snug and have not vibrated loose in transit.
9. Your new Magnetic Drill comes complete with arbor mounted. The 3/4" diameter arbor bore fits all 3/4"-shank "12,000-Series" Hougen Cutters.

**Reread Safety Warnings listed in the Operator's Manual and on the drill unit to avoid injury. Follow operating procedures.**

# OPERATION OF CONTROLS BEFORE INSTALLING HOUGEN CUTTER

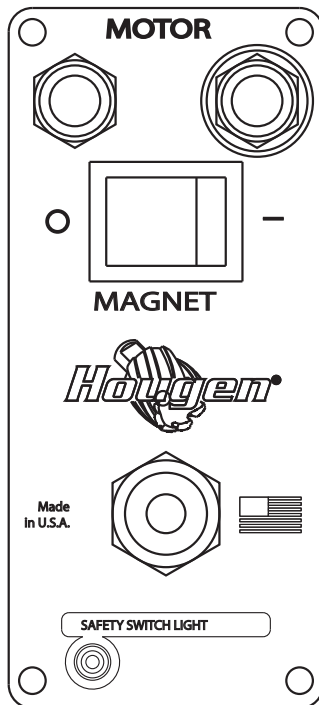

CONTROL PANEL SWITCH PLATE  
FIGURE 2

**IMPORTANT:** Before turning on the machine, it is important that the operator understands the interrelated functions of the **SAFETY SWITCH, MAGNET SWITCH, AND MOTOR SWITCHES.**

**READ SAFETY SWITCH INDICATOR LIGHT INSTRUCTIONS ON PREVIOUS PAGE.**

**SAFETY SWITCH** — Located in base of drill. Enables motor operation only when magnet is properly seated on a clean and flat work surface. Turns motor off if switch detects lift of unit.

**MAGNET ON/OFF SWITCH** — Energizes and De-energizes the magnetic base and activates the safety switch. Motor can now be started by pushing the motor **START** switch.

**MOTOR START/STOP SWITCHES** — Starts and stops the motor (See instructions previous page).

1. Place Magnetic Drill on clean, flat steel plate that is at least 3/8" thick.
2. Plug unit into proper AC power source. **DO NOT use with DC Power.**
3. Locate the Magnet **ON** and **OFF** switch and the motor **STOP** and **START** switch (Fig. 2).
4. **NOTE: A loss of power will de-energize the magnetic base and deactivate the motor. When power is restored, the magnet will reenergize, however, the motor START switch must be depressed before the motor will start.**

## OPERATING INSTRUCTIONS

Always remember that the magnet's holding power is directly related to the workpiece thickness and surface condition. Since magnetic attraction diminishes with thinner material or rough surfaces, mechanical clamping of drill unit to the workpiece should be used when cutting thin material (3/8" or less) or material with uneven surfaces.

1. Make sure workpiece and bottom of magnet are free of chips, oil, etc.
2. Position drill by sliding it and gently feeding Arbor so that pilot point is touching center of hole to be drilled.
3. **Secure unit to workpiece with safety chain.**
4. Turn magnet ON by pressing the magnet ON switch.
5. Turn Feed Handle, raising the cutter until the pilot is above the work surface.
6. Make certain that cutter is clear of workpiece and turn motor ON by pressing the motor START switch.
7. Feed Hougen Cutter slowly into workpiece. Only after cutting path is established to a depth of about 1/16" can full force be applied to feed handles.
8. Ease up on feed pressure as cutter starts breaking through.
9. At conclusion of cut, turn motor OFF by pressing motor STOP switch. Turn Feed Handles to raise Arbor thereby ejecting the slug if it hasn't already fallen free.
10. Turn magnet OFF by pressing the magnet OFF switch.
11. **Disconnect from power source.**
12. If necessary, remove chips from cutter and magnet, preferably wearing leather work gloves and/or with pliers. Disconnect safety chain and you are ready to move unit to new drilling position.

## INSTALLING HOUGEN CUTTER IN ARBOR

1. Disconnect from power source.
2. Lay drill on its side with feed handles up or be sure Arbor clears table if unit is in normal operating position.
3. Turn Feed Handles until cutter mounting set screws are exposed and completely remove the set screws.
4. Insert proper pilot in shank end of Hougen Cutter.
5. Insert Hougen Cutter until flat on cutter shank is aligned with set screw holes and is exactly perpendicular to axis of set screw holes.
6. Insert set screws and tighten. Check to be certain that cutter is secure.

## OPERATION OF CUTTING FLUID RESERVOIR

1. With Magnetic Drill in operating position, turn the feed handles so that cutter and pilot are above the work surface.
2. With magnet turned ON and motor OFF, fill reservoir by introducing cutting fluid through slots in Arbor.  
**Cutting fluid should not leak out.**
3. Test metering capabilities of Arbor/Cutter/Pilot assembly (magnet ON-motor OFF) by feeding the Arbor gently toward work surface until pilot is pushed up into Cutter, thus allowing fluid to filter down onto work surface through groove in pilot.
4. For proper lubrication, all cutting fluid in reservoir should empty onto work surface in no less than 15 seconds and no longer than 30 seconds.

## ADJUSTMENT OF GIBS

1. Loosen all Gib Screws (40237).
  2. Feed the drill in and out a few times and then, with top of motor slide flush with top of housing, tighten the Gib Screws until you feel them touch the Steel Gib (02431).
  3. Feed the drill in and out again.
  4. Adjust Gib Screws so that there is uniform pressure from top to bottom. (Top of motor slide flush with top of housing.)
  5. Turn each Gib Screw in about 1/8 to 1/4 turn, depending upon your preference.
  6. Gibs should be tight enough so that slide moves up and down smoothly with no wobble or shaking. (Looseness will cause cutter breakage.)
- NOTE: Gibs should be lubricated regularly.**

## ARBOR & FRONT SUPPORT BRACKET REMOVAL AND INSTALLATION

### Removal

1. Loosen arbor support bracket bolts.
2. Loosen set screws holding arbor onto motor output shaft.
3. Remove arbor.

### Installation

1. Hand tighten front support bracket bolts. Do not tighten all the way.
2. Slide arbor to full up position and hold arbor in position over hex drive motor output shaft.
3. Tighten two set screws to hold arbor onto motor output shaft.
4. Turn feed handle until motor and arbor are at the bottom of their travel.
5. Tighten front support bracket bolts to 400 in/lbs.
6. Run motor for 10 seconds. (If visual movement of arbor is noticed, restart at step 1)
7. Re-check for tightness of arbor set screws.

## ARBOR ADJUSTMENT

**Adjust Gibs before adjusting front support bracket.**

1. Loosen Arbor Support Bracket Bolts.
2. Be sure top of arbor is flush with the shoulder on motor output shaft. Also make certain arbor is securely fastened.
3. Turn feed handle until motor and spindle are at the bottom of their travel.
4. Tighten Arbor Support Bolts.
5. Feed slide up and down a few times, checking for free and uniform movement.

**NOTE: Check Arbor support bolts regularly to make certain they are tight. Tighten as required.**

# MAINTENANCE

In order to minimize wear on moving parts and to insure smoother operation and longer life for your magnetic drill, the following maintenance should be done periodically, based on use.

1. Regularly tighten all fasteners and replace all worn parts.
2. Check motor brushes and replace if worn. (Break in period - 30 minutes at no load speed)
3. Check power cord and cord from panel to motor and, if cracked or frayed, return to an authorized repair center for replacement.
4. Apply grease to the slide dovetails, brass gibs, and the feed gear rack. For best results use Shell Cyprina-RA or equivalent.
5. Remove arbor and pack the bearing in the front support bracket with grease. Use Shell Cyprina-RA or equivalent.

# HINTS FOR SMOOTHER OPERATION

1. Keep insides of Hougén Cutter clear of chips. Chips will interfere with cutting to maximum depth, may impede the free oil flow and can cause cutter breakage.
2. Keep work, machine, arbor and Hougén Cutter free of chips and dirt.
3. Tighten all bolts and fasteners regularly.
4. We highly recommend using a light viscosity cutting fluid (preferably Hougén Cutting Fluid - Part No. 11742-4)
5. Occasionally check metering of cutting fluid flow. Lack of cutting fluid may cause Hougén Cutter to freeze in cut, slug to stick and may result in poor cutter life.
6. Always start cut with light feed pressure and then increase sufficiently to achieve maximum cutting rate.
7. Ease off on pressure as cutter begins to break through at the end of the cut.
8. Keep slide dovetails, brass gibs and feed rack lubricated and free of chips and dirt.
9. When slug hangs up in cutter, turn off motor and bring cutter down on a flat surface. This will normally straighten a cocked slug, allowing it to be ejected.
10. When cutting large diameter or deep holes it may be necessary to stop in the middle of the cut to add cutting fluid and remove the chips from around the arbor. (When doing this DO NOT raise the cutter out of the hole. Doing so can allow chips to get under the teeth of the cutter and make it difficult to restart the cut.)

**#1 cause of cutter breakage and prematurely dull teeth is too little feed pressure\***

\* **"Babying" the cutter through the cut will only decrease tool life.**

# REMEDIES FOR HOLEMAKING PROBLEMS

1. **Trouble: Magnetic base won't hold effectively to work.**
  - a. Cause: Chips or dirt under magnet.  
*Remedy:* Clear area of chips and dirt.
  - b. Cause: Irregular surface on bottom of magnet or on workpiece.  
*Remedy:* Lightly surface grind the bottom of the magnet flat and/or file imperfections flat on the work surface as needed.
2. **Trouble: Cutter tends to move across surface of work.**
  - a. Cause: Magnetic base not holding effectively.  
*Remedy:* See causes and remedies under No. 1 above.
  - b. Cause: Too much feed pressure at start of cut.  
*Remedy:* Light pressure until a groove is cut. The groove then serves as a stabilizer.
  - c. Cause: Worn pilot.  
*Remedy:* Replace pilot
3. **Trouble: Out of round holes.**
  - a. Cause: Worn arbor support bracket bearing and or ejector collar.  
*Remedy:* Replace: (only a few thousandths wear permissible.)
  - b. Cause: Misaligned support bracket  
*Remedy:* Realign support bracket
  - c. Cause: Misaligned or loose arbor set screws.  
*Remedy:* Tighten set screws.
4. **Trouble: Motor and slide won't stay in set position**
  - a. Cause: Gibs too loose  
*Remedy:* Adjust gibs
5. **Trouble: Erratic or intermittent feed.**
  - a. Cause: Worn or pinion and/or rack.  
*Remedy:* Replace worn parts.
6. **Trouble: Motor doesn't run when motor START button is pushed.**
  - a. Cause: Magnet is not turned on  
*Remedy:* Push magnet ON button.
  - b. Cause: Magnet on rough or dirty work surface and safety switch not fully depressed.  
*Remedy:* File work surface flat and clean all chips and oil from under magnet.
  - c. Cause: No power  
*Remedy:* Check power source and extension cords.
  - e. Cause: Worn motor brushes  
*Remedy:* Replace brushes
  - f. Cause: Faulty motor START switch  
*Remedy:* Return unit to an authorized repair center to have switch replaced.

**NOTE: If you are unable to correct any malfunction after trying the above, do not attempt to operate the drill. Return the unit to the factory or authorized repair center for service.**



# SWIVEL BASE ADJUSTMENTS

## ATTENTION

The threads on the Clamp Handle Assembly are a Left Handed thread meaning,  
Turning Clockwise would loosen the assembly  
Turning Counter Clockwise would tighten the assembly.

Also, the Clamp Handle Assembly is spring loaded so you will need to lift & turn the entire Clamp Handle Assembly when repositioning as if to be a ratchet device.

### To Loosen the Swivel Plate Assembly

1. Lift the Clamp Handle Assembly, rotated counter-clockwise and release .  
This will reposition the lever for more movement.

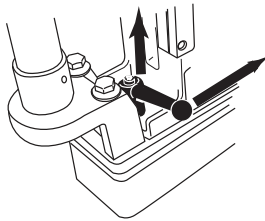

2. With the Clamp Handle Assembly now down, pull the Clamp Handle Assembly clockwise.

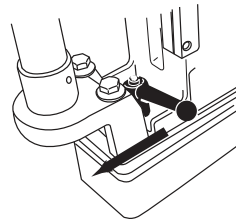

With this being a left handed thread this will loosen this assembly.

3. If more travel is needed lift the Clamp Handle Assembly, rotate counter clockwise and release.

4. Pull the Clamp Handle Assembly clockwise again.

This amount of movement should be adequate to reposition the Drill Assembly.

More movement than this may cause the Magnet Assembly to disengage from the drill base.

### To Tighten the Swivel Plate Assembly.

1. Lift the Clamp Handle Assembly, rotated clockwise and release .  
This will reposition the lever for more movement.

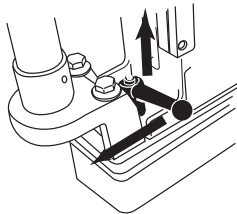

2. With the Clamp Handle Assembly now down, push the Clamp Handle Assembly counter clockwise.

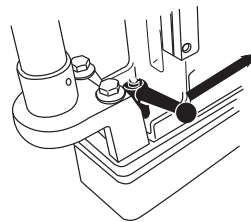

With this being a left handed thread this will tighten this assembly.

3. If more travel is needed lift the Clamp Handle Assembly, rotate clockwise and release.

4. Push the Clamp Handle Assembly counter clockwise again.

Continue this process until the Swivel Assembly is tight.



**WARNING :**  
**CLAMP HANDLE MUST BE TIGHT PRIOR TO CUTTING HOLES -**  
**EQUIPMENT DAMAGE OR PERSONAL INJURY COULD OCCUR**

## SAFETY CHAIN INSTALLATION

The safety chain should be used to prevent the drill unit from falling in the event of a power failure or if the magnet breaks loose from the work surface. The safety chain should be attached to the drill by running it between the Front Support Bracket and the Drill Housing and then continue around the material and/or work surface. Adjust the chain so it is tight and secure. Please refer to the diagram.

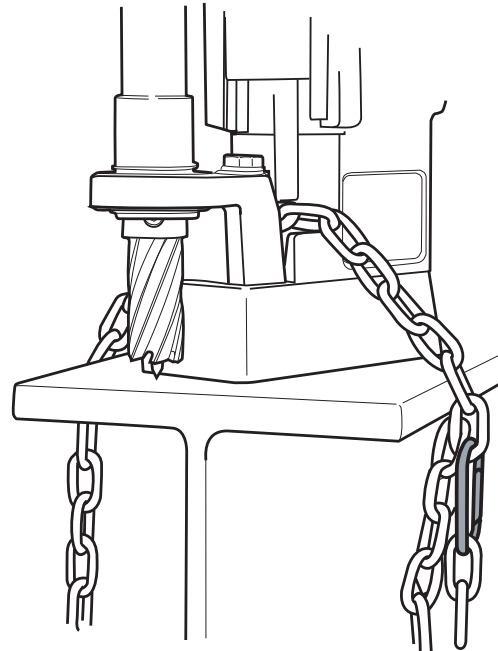

## COOLANT BOTTLE ASSEMBLY

### 05060 Coolant Bottle Assembly

05064	Round Bottle
05059	Coolant Bottle Bracket (Bottle to Bracket)
05061	Thumb Screw (holds bottle bracket to mounting bracket)
05065	Ball Valve
05067	Brass Barb Fitting (bottom of the bottle)
40304	Vinyl Tube
07080	Brass Fitting (vinyl tube to coolant inducer) not included in 05060 kit.

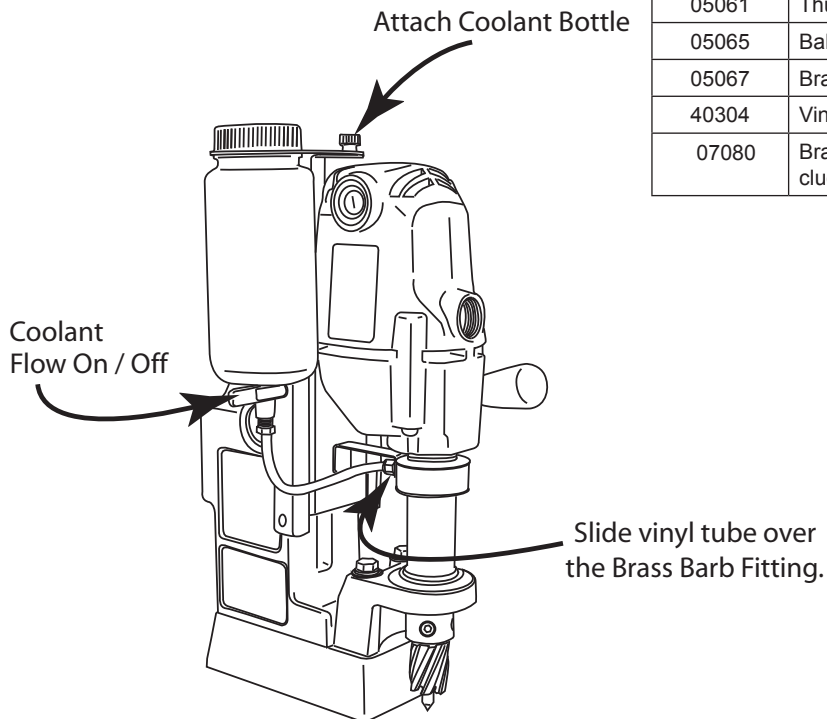

# 0904301 - HMD904 230v Type I Plug

# 0904401 - HMD904 230v, no plug

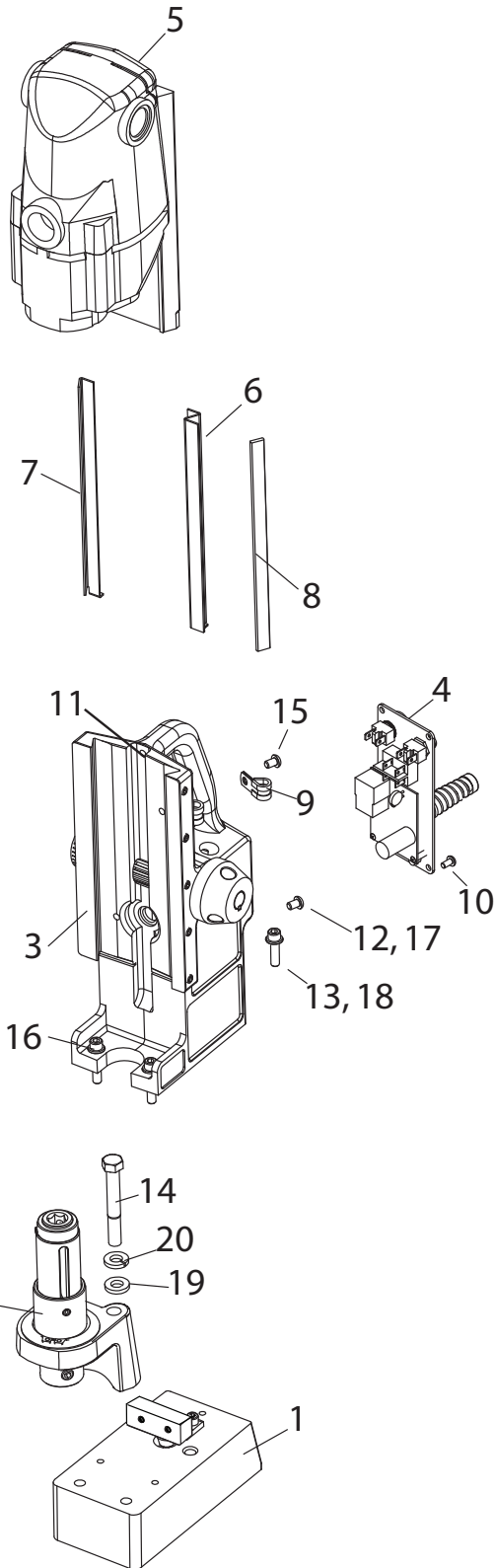

Item	Part #	Description	Qty
1	*05392	Magnet & Switch Assembly Standard Base <b>230v</b>	1
2	*05470	Arbor/Front Support Assembly	1
3	*04540	Housing Assembly <b>230v</b>	1
4	*05946	Panel Assembly <b>230v (0904301)</b>	1
	*05290	Panel Assembly <b>230v (0904401)</b>	1
5	Refer to the following pages for the Motor/Slide Assembly Breakdown		
6	02429	Brass Gib Right Hand	1
7	02430	Brass Gib Left Hand	1
8	02431	Steel Gib	1
9	02420	Cable Clamp	1
10	41044	Screw BHC #10-32 X 3/8	4
11	40432	Screw SHC 1/4-28 X 3/8	1
12	17002	Screw SHC #6-32 X 1/2 (ground)	1
13	40077	Screw SHC 1/4-20 X 1	1
14	02460	Hex Bolt 3/8-24 X 2-3/4	2
15	02461	Screw BHC 1/4-28 X 3/8	1
16	10553	Screw SHC 1/4-20 X 7/8	2
17	90052	Lock Washer	1
18	90028	Lock Washer	3
19	40392	Flat Washer	2
20	40391	Lock Washer	2
<b>Accessories Included</b>			
	10565	Hex Key 1/8 wrench	1
	10730	Safety Chain 3/16 X 5' w/Snap Hook	1
	04550	Carrying Case w/Label	1
	02635	Hex Key 3/16" T-Handle	1
<b>* See Following Pages for Detailed Breakdowns</b>			

The **0904301** is assembled with a Type I Plug.

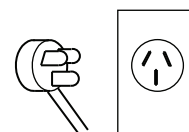

The **0904401** is assembled without an electrical plug at the end of the power cord.

# 0904302 - HMD904 230v with Coolant, Type I Plug

# 0904402 - HMD904 230v with Coolant, No Plug

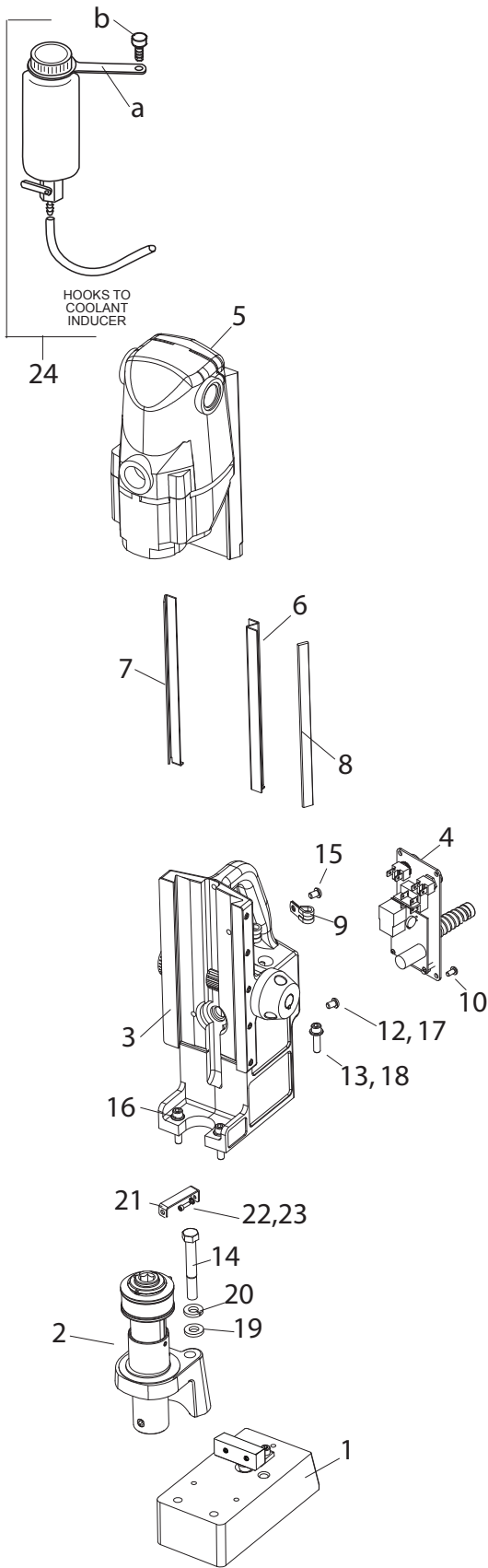

Item	Part #	Description	Qty
1	*05392	Magnet & Switch Assembly Standard Base	1
2	*07155	Arbor/Front Support Assembly	1
3	*04540	Housing Assembly	1
4	*05946	Panel Assembly <b>230v (0904302)</b>	1
	*05290	Panel Assembly <b>230v (0904402)</b>	1
5	Refer to the following pages for the Motor/Slide Assembly Breakdown		
6	02429	Brass Gib Right Hand	1
7	02430	Brass Gib Left Hand	1
8	02431	Steel Gib	1
9	02420	Cable Clamp	1
10	41044	Screw BHC #10-32 X 3/8	4
12	17002	Screw SHC #6-32 X 1/2 (ground)	1
13	40077	Screw SHC 1/4-20 X 1	1
14	02460	Hex Bolt 3/8-24 X 2-3/4	2
15	02461	Screw BHC 1/4-28 X 3/8	1
16	10553	Screw SHC 1/4-20 X 7/8	2
17	90052	Lock Washer	1
18	90028	Lock Washer	3
19	40392	Flat Washer	2
20	40391	Lock Washer	2
21	07163	Coolant Inducer Bracket	1
22	40038	Screw SHC #10-32 X 5/8	1
23	10560	Lock Washer	1
24	05060	Coolant Bottle Assembly	1
a	05059	Coolant Bottle Holder	1
b	05061	Thumb Screw	1
<b>Accessories Included</b>			
	10565	Hex Key 1/8 wrench	1
	10730	Safety Chain 3/16 X 5' w/Snap Hook	1
	04550	Carrying Case w/Label	1
	02635	Hex Key 3/16" T-Handle	1
	02677	3/4 Nom Pipe - Handle <b>0904402</b>	1
<b>* See Following Pages for Detailed Breakdowns</b>			

The **0904302** is assembled with a Type I Plug.

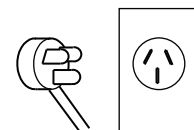

The **0904402** is assembled without an electrical plug at the end of the power cord.

1164

**0904303 - HMD904 230v, Swivel Base, Type I Plug**

**0904403 - HMD904 230v, Swivel Base, No Plug**

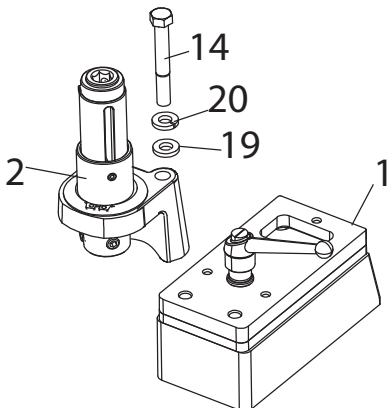
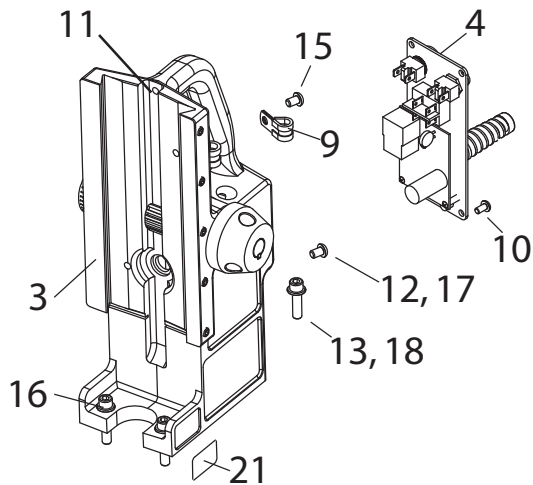
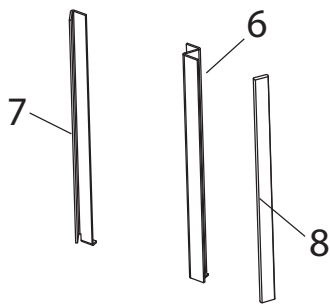
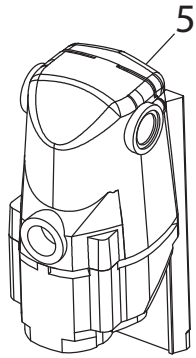

Item	Part #	Description	Qty
1	*05894	Magnet & Switch Assembly Swivel Base	1
2	*05733	Arbor/Front Support Assembly	1
3	*04540	Housing Assembly	1
4	*05946	Panel Assembly <b>230v (0904303)</b>	1
	*05290	Panel Assembly <b>230v (0904403)</b>	1
5	Refer to the following pages for the Motor/Slide Assembly Breakdown		
6	02429	Brass Gib Right Hand	1
7	02430	Brass Gib Left Hand	1
8	02431	Steel Gib	1
9	02420	Cable Clamp	1
10	41044	Screw BHC #10-32 X 3/8	4
11	40432	Screw SHC 1/4-28 X 3/8	1
12	17002	Screw SHC #6-32 X 1/2 (ground)	1
13	40077	Screw SHC 1/4-20 X 1	1
14	05736	Hex Bolt 3/8-24 X 2	2
15	02461	Screw BHC 1/4-28 X 3/8	1
16	10553	Screw SHC 1/4-20 X 7/8	2
17	90052	Lock Washer	1
18	90028	Lock Washer	3
19	40392	Flat Washer	2
20	40391	Lock Washer	2
21	07015	Swivel Base Label lock/unlock	1
<b>Accessories Included</b>			
	10565	Hex Key 1/8 wrench	1
	10730	Safety Chain 3/16 X 5' w/Snap Hook	1
	04550	Carrying Case w/Label	1
	02635	Hex Key 3/16" T-Handle	1
<b>* See Following Pages for Detailed Breakdowns</b>			

The **0904303** is assembled with a Type I Plug.

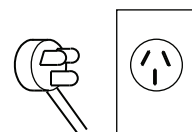

The **0904403** is assembled without an electrical plug at the end of the power cord.

**0904304** - HMD904 230v, Coolant, Swivel Base with Type I Plug

**0904404** - HMD904 230v, Coolant & Swivel Base for Singapore

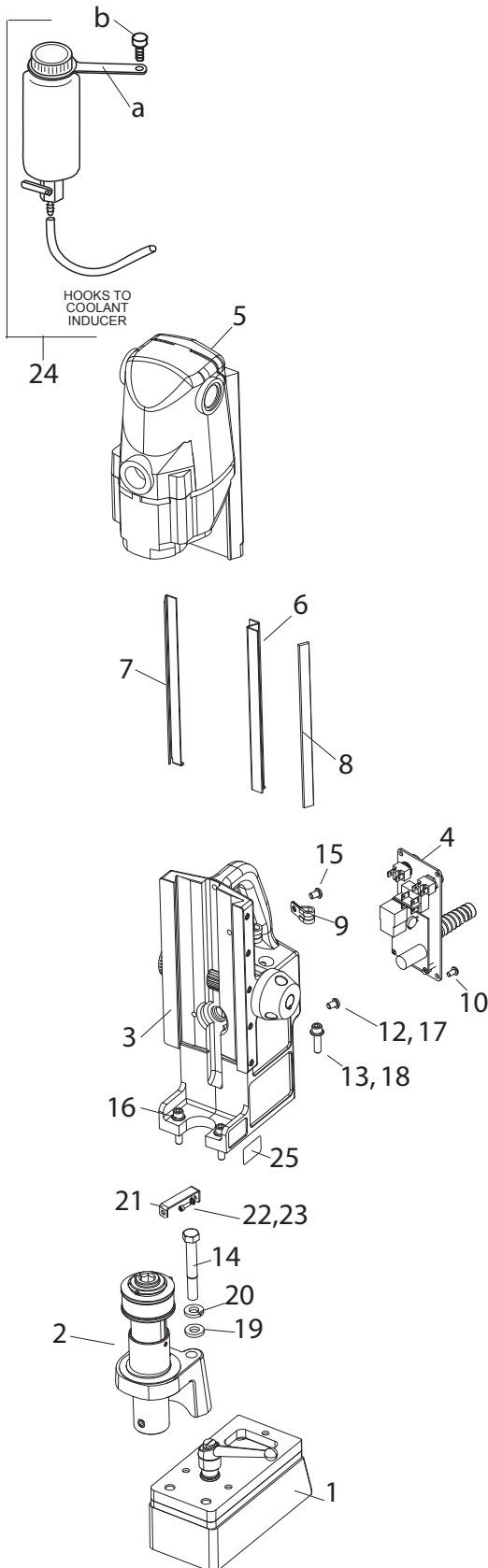

Item	Part #	Description	Qty
1	*05894	Magnet & Switch Assembly Swivel Base	1
2	*07156	Arbor/Front Support Assembly	1
3	*04540	Housing Assembly	1
4	*05946	Panel Assembly <b>0904304</b>	1
	*05290	Panel Assembly <b>0904404</b>	1
5	Refer to the following pages for the Motor/Slide Assembly Breakdown		
6	02429	Brass Gib Right Hand	1
7	02430	Brass Gib Left Hand	1
8	02431	Steel Gib	1
9	02420	Cable Clamp	1
10	41044	Screw BHC #10-32 X 3/8	4
12	17002	Screw SHC #6-32 X 1/2 (ground)	1
13	40077	Screw SHC 1/4-20 X 1	1
14	05736	Hex Bolt 3/8-24 X 2	2
15	02461	Screw BHC 1/4-28 X 3/8	1
16	10553	Screw SHC 1/4-20 X 7/8	2
17	90052	Lock Washer	1
18	90028	Lock Washer	3
19	40392	Flat Washer	2
20	40391	Lock Washer	2
21	07163	Coolant Inducer Bracket	1
22	40038	Screw SHC #10-32 X 5/8	1
23	10560	Lock Washer	1
24	05060	Coolant Bottle Assembly	1
a	05059	Coolant Bottle Holder	1
b	05061	Thumb Screw	1
25	07015	Swivel Label lock/unlock	1
<b>Accessories Included</b>			
	10565	Hex Key 1/8 wrench	1
	10730	Safety Chain 3/16 X 5' w/Snap Hook	1
	04550	Carrying Case w/Label	1
	02635	Hex Key 3/16" T-Handle	1
	02677	3/4 Nom. Pipe <b>0904404</b>	1
* See Following Pages for Detailed Breakdowns			

The **0904304** is assembled with a Type I Plug.

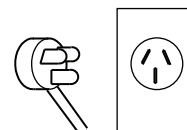

The **0904404** is assembled without an electrical plug at the end of the power cord.

1164

# Magnet Assembly Breakdowns

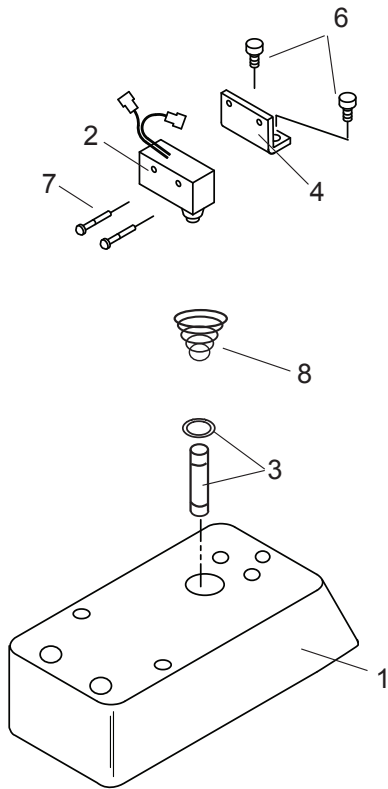

05392 Magnet Assembly 230v			
Item	Part #	Description	Qty
1	05391	Magnet Assembly 230v	1
2	04885	Safety Switch Assembly	1
3	04910	Plunger Assembly	1
4	04909	Safety Switch Bracket	1
6	10971	Screw SHC 1/4-20 X 1/2	2
7	10972	Screw BHC #6-32 X 7/8	2
8	17271	Tapered Spring	1

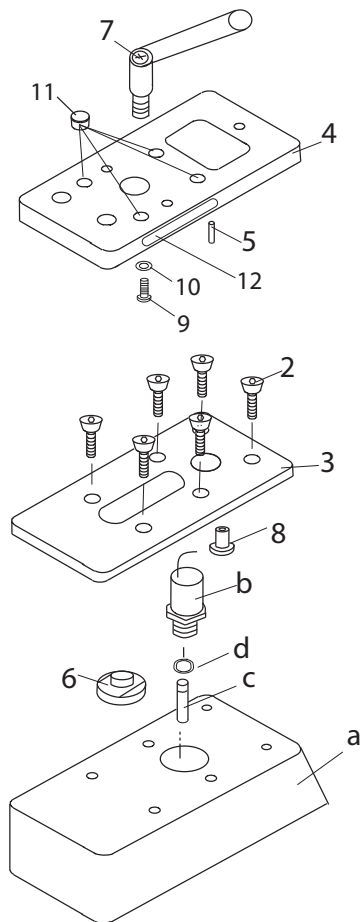

05894 Swivel Magnet Assembly 230v			
Item	Part #	Description	Qty
1	05895	Magnet/Safety Switch Assembly 230v includes a-c	
a	05896	Magnet Assembly 230v	1
b	05652	Ball Switch Assembly	1
c	05653	Plunger	1
d	05670	Retain. Ring	1
2	05743	Screw FHC 1/4-20 X 3/4	6
3	05657	Slide Housing	1
4	05656	Swivel Housing	1
5	02898	Dowel Pin	1
6	05658	Pivot Rod	1
7	05659	Clamp Handle Assembly	1
8	07215	Bushing Flange	1
9	41044	Screw BHC #10-32 X 3/8	1
10	90237	Flat Washer #10	1
11	07216	9/16 Hole Plug	4
12	07230	Safety Label	1

# Arbor/Front Support Assembly Breakdowns

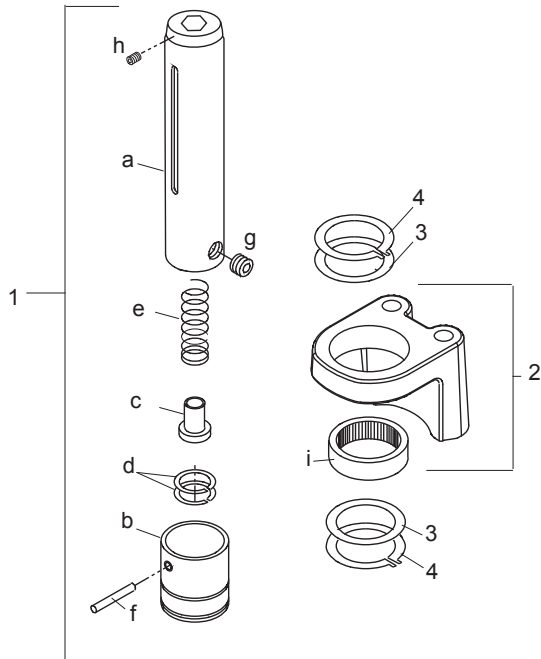

<b>05470 Arbor &amp; Front Support Bracket Assy. non-swivel</b>			
<b>05733 Arbor &amp; Front Support Bracket Assy. swivel</b>			
Item	Part #	Description	Qty
1	05469	Arbor & Collar Assembly (swivel & non-swivel base)	1
a	05458	Arbor Body	1
b	01441	Ejection Collar	1
c	01439	Spring Seat	1
d	10517	Retain. Ring	2
e	05049	Spring	1
f	40312	Roll Pin	1
g	10506	Set Screws 3/8-24 X .305	2
h	05628	Set Screw 1/4-28 X 3/8	2
2	04375	Front Support Bracket (non-swivel)	1
	05734	Front Support Bracket (swivel)	1
j	40232	Needle Bearing	1
3	40234	Thrust Washer	2
4	40398	Retain. Ring	2

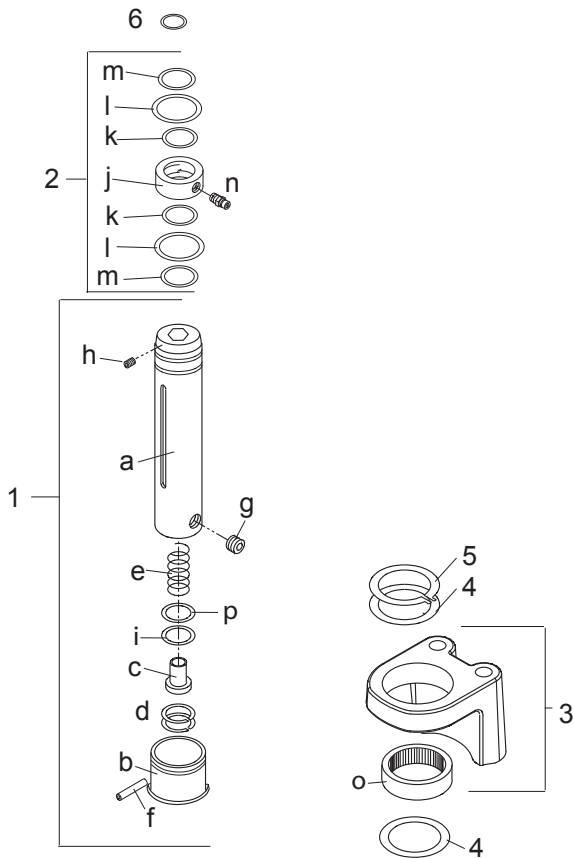

<b>07155 Coolant Arbor Assembly</b>			
<b>07156 Coolant Arbor Assembly</b>			
Item	Part #	Description	Qty
1	07157	Arbor & Collar Assembly	1
a	07159	Arbor Body	1
b	07162	Ejection Collar	1
c	07161	Spring Seat	1
d	10517	Retain. Ring	2
e	05049	Spring	1
f	40312	Roll Pin	1
g	10506	Set Screws 3/8-24 X .305	2
h	05628	Set Screw 1/4-28 X 3/8	2
i	07436	Rubber Washer	1
p	07440	Shim Washer	1
2	07158	Coolant Inducer Assembly	1
j	07160	Inducer Ring	1
k	40300	O-Ring	2
l	40301	Washer	2
m	40302	Retain Ring	2
n	07080	Hose Fitting	1
3	04375	Front Support Bracket Assembly for the <b>07155</b>	1
	05734	Front Support Bracket Assembly for the <b>07156</b>	1
o	40232	Needle Bearing	1
4	40234	Thrust Washer	2
5	40398	Retain. Ring	1
6	04391	O-Ring	1



# Housing Assembly Breakdown

04540 Housing Assembly			
Item	Part #	Description	Qty
1	04541	Housing Assembly for 04540 assy. (includes a-f)	1
a	04530	Warning Label for 04540 assy.	2
b	04529	Safety Label (shown)	1
c	04553	Safety Chain Label for 04540 assy	1
d	40229	Feed Gear	1
e	40231	Bronze Bushing	2
f	40237	Gib Screws	5
2	40254	Hub Assembly	1
3	05839	Comfort Grip Knob	1
4	10679	Flat Washer	1
5	04558	Feed Handle	3
6	04532	Feed Handle Knob	3
7	02411	Strain Relief	1

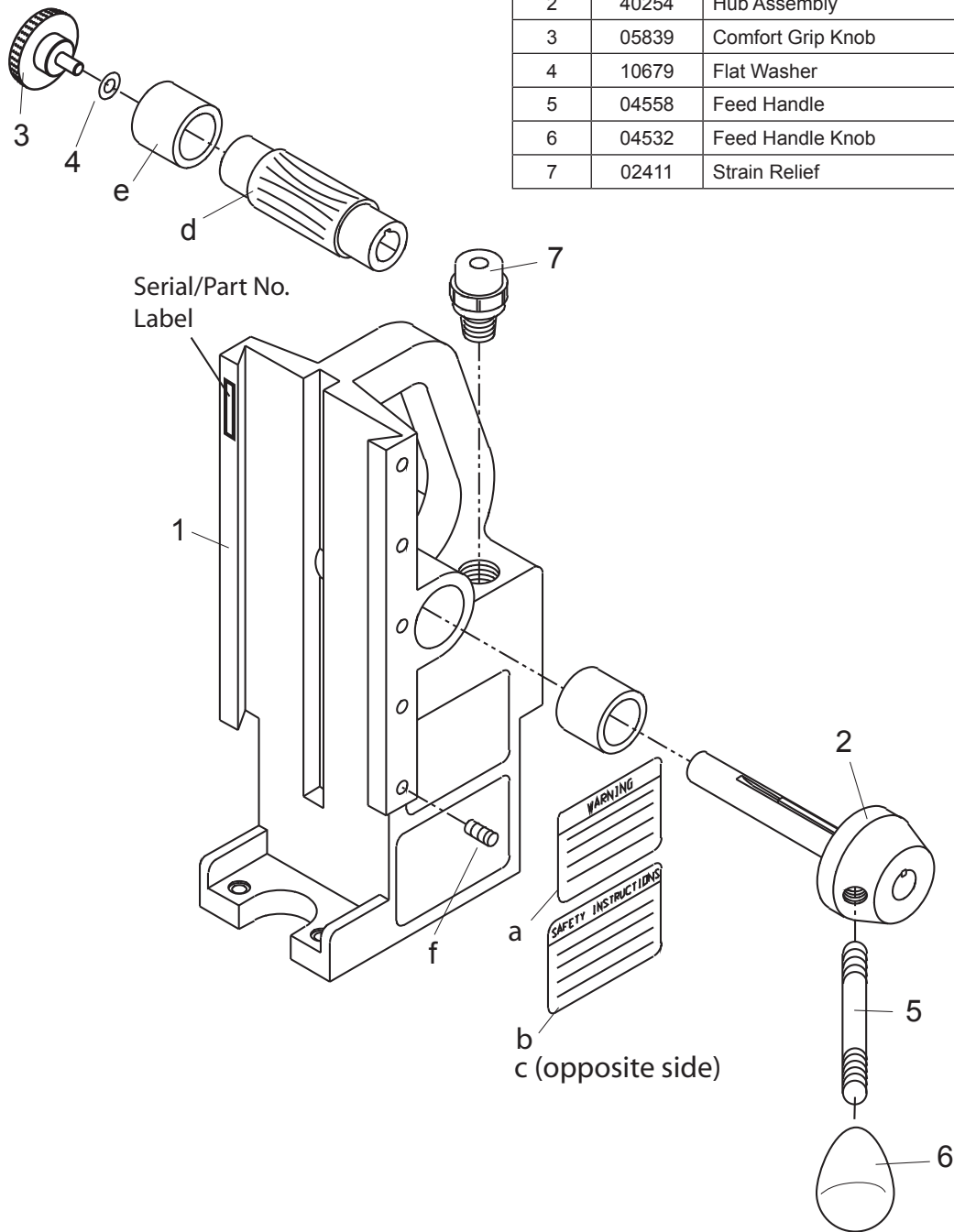

# Control Panel Breakdown 230v

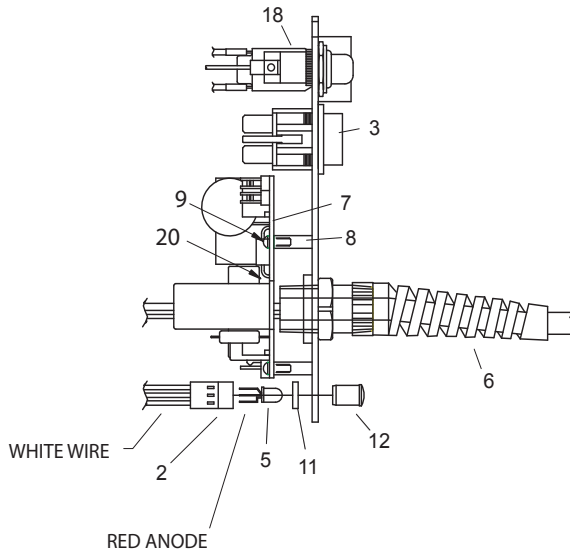

NOTE: WHEN INSERTING L.E.D. DETAIL#5 INTO HARNESS DETAIL#2 MAKE SURE FLAT ON BULB LINES UP WITH WHITE WIRE ON HARNESS.

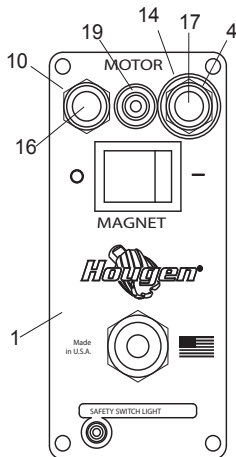

## 05946 230v Control Panel, Type I Plug

(0904301,0904302,0904303 & 0904304)

## 05290 230v Control Panel, Standard Plug

(0904401,0904402,0904403 & 0904404)

Item	Part #	Description	Qty.
1	05929	Faceplate	1
2	04877	Wire Harness	1
3	04664	Magnet Switch	1
4	01334	Motor ON Switch	1
5	04881	Bulb L.E.D	1
6	04498	Power Cord (230v) for the <b>05946</b>	1
	05424	Power Cord (230v) for the <b>05290</b>	1
7	05827	Circuit Board (230v)	1
8	02548	Stand-Off 3/16 x 9/16 LG	3
9	02547	#4-40X5/16 Phillips Head Screw	3
10	01335	Motor OFF Switch	1
11	04878	Spacer	1
12	04879	Clear Lens	1
13	*90690	Cable Tie	1
14	01226	Switch Guard	1
15	*05205	Wire Harness (board to housing)	1
16	01228	Red Switch Cover	1
17	02409	Green Switch Cover	1
18	05926	Circuit Breaker	1
19	05928	Rubber Boot Seal	1
20	07522	Fuse	2
		*not shown	

The **05946** is assembled with a Type I Plug.

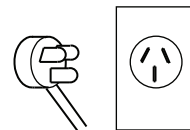

The **05290** is assembled with a standard U.S.A 230v Plug at the end of the Power Cord. When installing the 05290 Control Panel or 05424 Power Cord into a 0904401, 0904402, 0904403 & 0904404 this plug will need to be changed.

# 230v Wiring Diagram

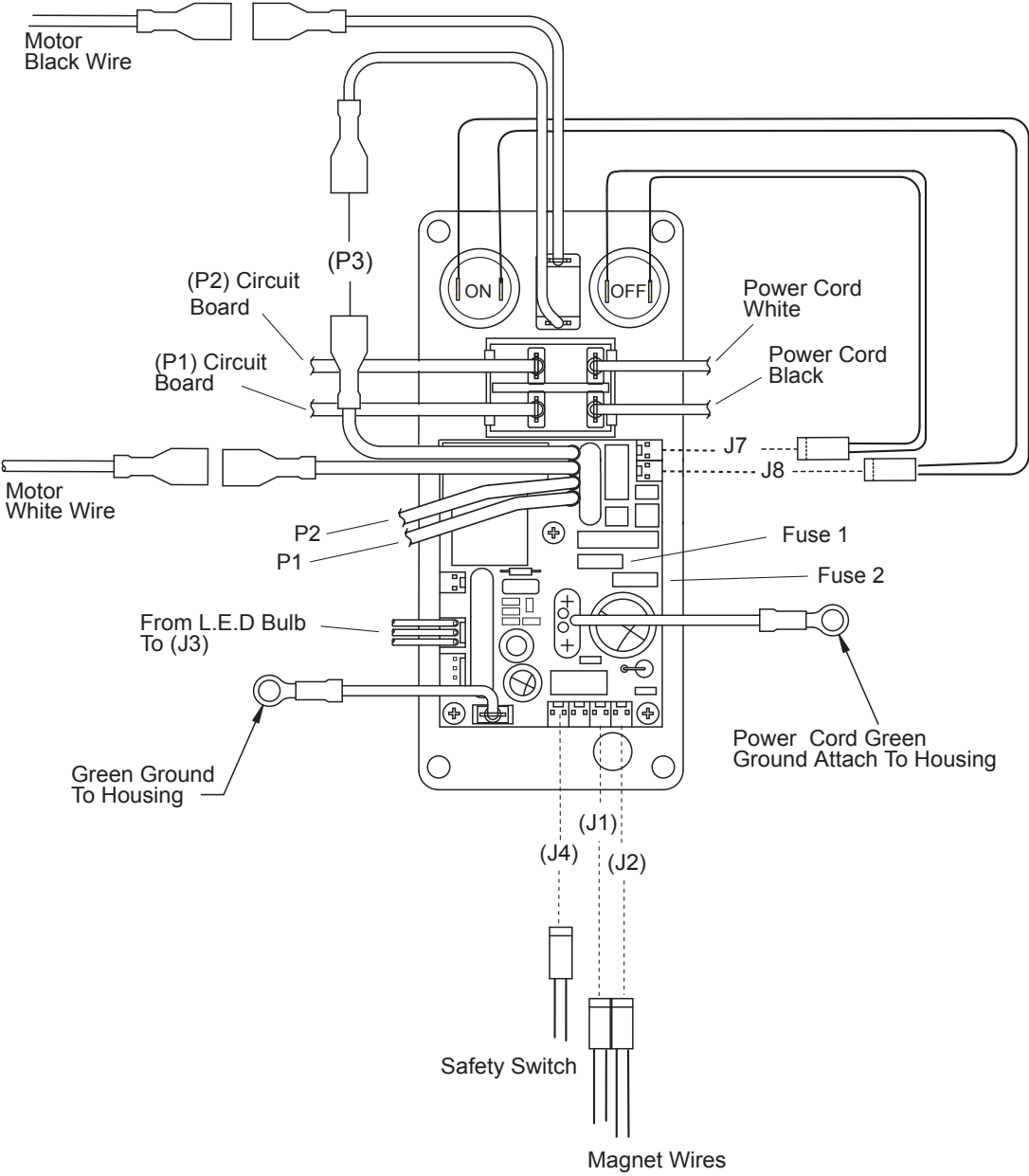

# Motor Slide Assembly Breakdown

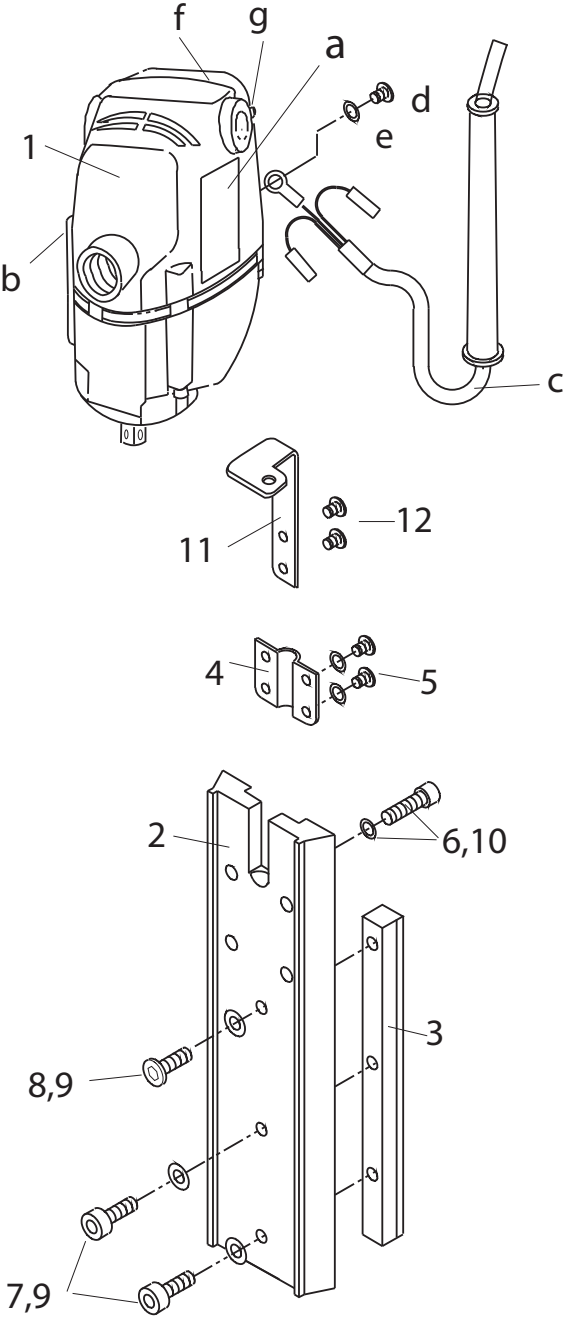

Motor & Slide Assemblies 230v			
Item	Part #	Description	Qty
1	07181	Motor Assembly <b>230v</b>	1
a	04527	Motor Label	1
b	04042	Specs Label <b>230v</b>	1
c	02413	Motor Cord	1
d	11053	Screw BHS #8-32 X 3/16	1
e	10538	Lock Washer	1
f	04502	Inspection Cover	1
g	75289	Screw Pan Head M5 X 8MM	2
2	04500	Slide for <b>0904301, 302, 401 &amp; 402</b>	1
	05824	Slide for <b>0904303, 304, 403 &amp; 404</b>	1
3	02428	Rack Gear for <b>0904301, 302, 401 &amp; 402</b>	1
	05825	Rack Gear for <b>0904303, 304, 403 &amp; 404</b>	1
4	02422	Motor Cord Bracket	1
5	41044	Screw BHC #10-32 X 3/8	4
6	75156	Screw SHC M6 X 1 X 15mm	4
7	40038	Screw SHC #10-32 X 5/8	2
8	90077	Screw BHC #10-32 X 1/2	1
9	10560	Lock Washer	3
10	90028	Lock Washer	4
<b>Items 11 &amp; 12 are used with 0904302, 402, 304 &amp; 404</b>			
11	05057	Bottle Holder Bracket	1
12	05988	Screw FHC #10-32 X 1/2	2

# Motor Parts Diagram 230v

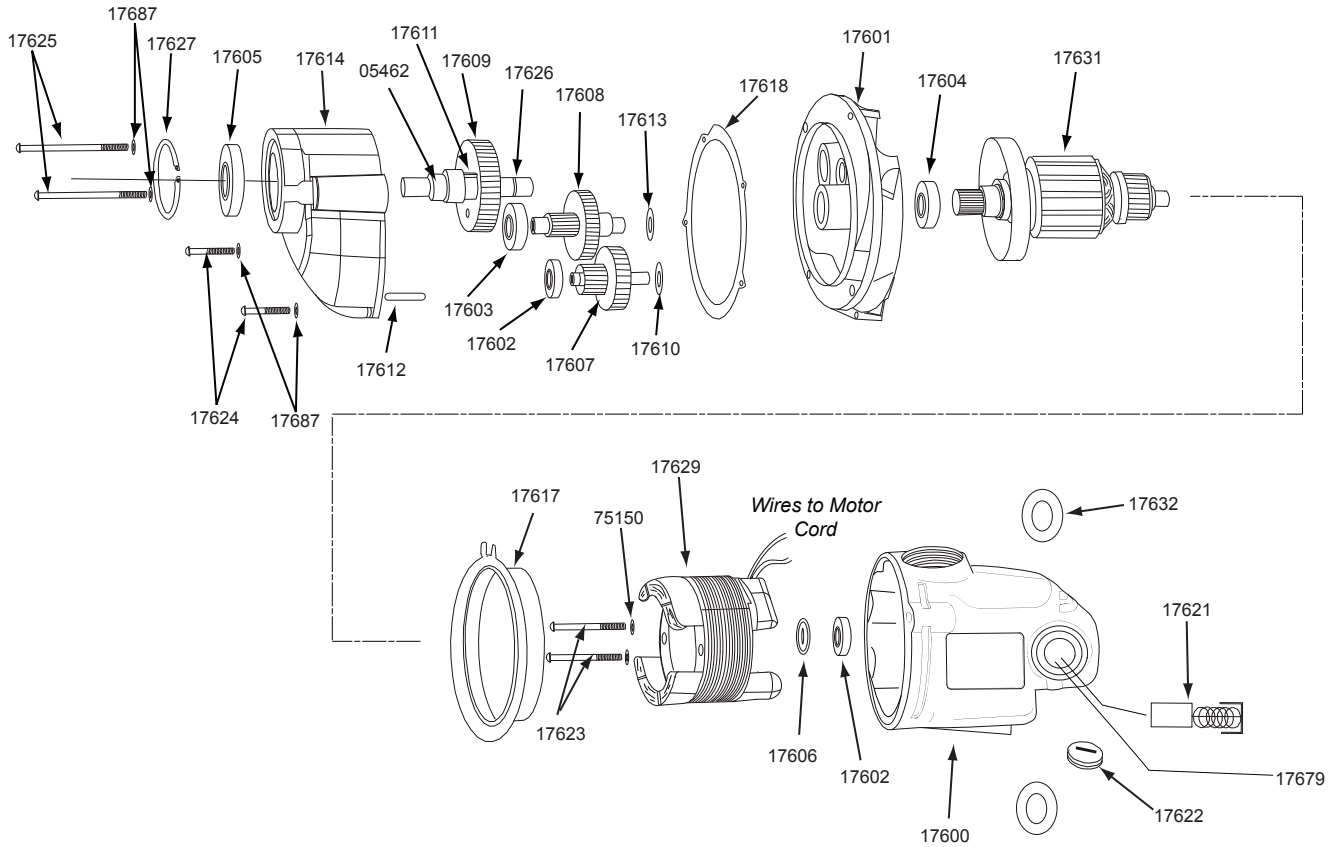

Part #	Description	Qty	Part #	Description	Qty
05462	Hex Spindle	1	17617	Fan Guide	1
17600	Field Case	1	17618	Gasket	1
17601	Gear Housing	1	17621	Carbon Brush (Pair)	1
17602	Ball Bearing	2	17622	Brush Cap	2
17603	Ball Bearing	1	17623	Pan Head Screw	2
17604	Ball Bearing	1	17624	Pan Head Screw Short	2
17605	Ball Bearing	1	17625	Pan Head Screw Long	2
17606	Dust Seal	1	17626	Retaining Ring	1
17607	1st Inter. Gear Assy	1	17627	Retaining Ring	1
17608	2nd Inter. Gear Assy	1	17629	Field	1
17609	Spur Gear	1	17631	Armature	1
17610	Flat Washer	1	17632	Paper Washer	2
17611	Key	1	17679	Brush Holder	2
17612	Dowel Pin	1	17687	Lock Washer	4
17613	Flat Washer	1	75150	Lock Washer	2
17614	Gear Housing	1			

# Notes

# Notes