

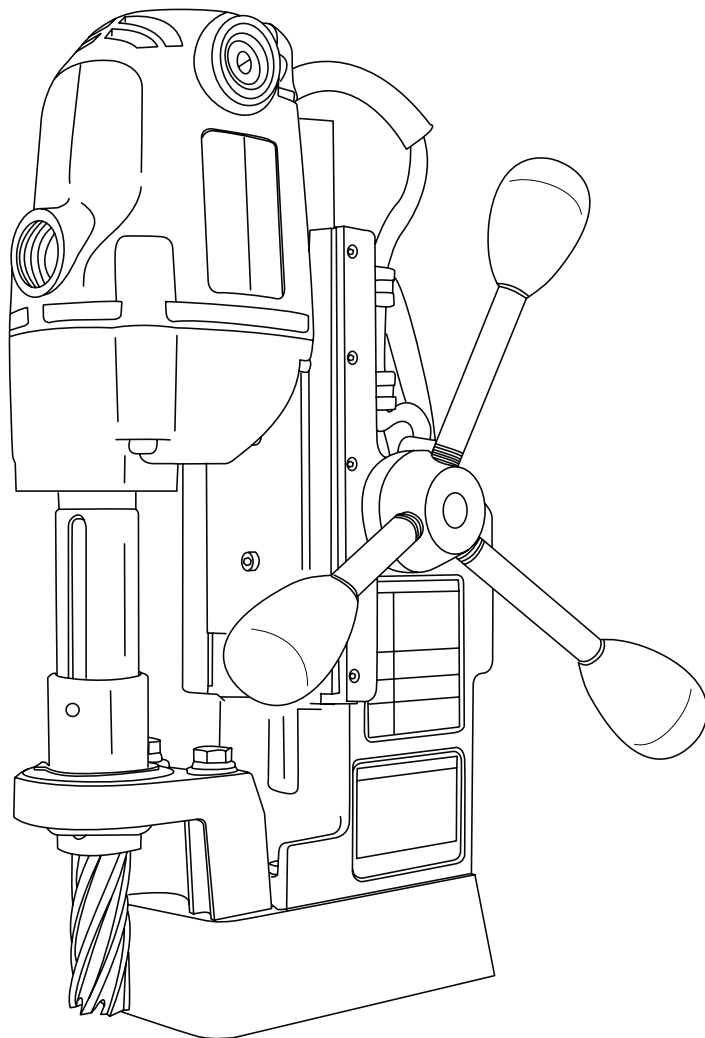

# HMD904

## PORTABLE MAGNETIC DRILL

# OPERATOR'S MANUAL



FOR USE WITH "12,000-SERIES" HOUGEN® CUTTERS

# HOUGEN®

## Portable Magnetic Drill

Model HMD904

### Welcome to Hougen

Congratulations on your purchase of the Hougen® Portable Magnetic Drill Model HMD904. Your model is designed to produce superior holes quickly and efficiently. Through constant innovation and development, Hougen is committed to provide you with hole-producing tools and products to help you be more productive.

Before attempting to operate your new Portable Magnetic Drill, please read all instructions first. These include the Operator's Manual and Warning Label on the unit itself. With proper use, care, and maintenance, your model will provide you with years of effective hole drilling performance. Once again, thank you for selecting our product and welcome to Hougen.

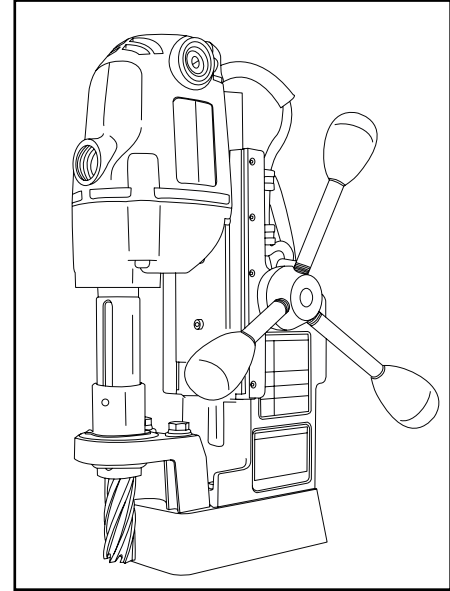

#### Specifications

Cutter Type.....Hougen "12,000-Series"  
Hole Capacity.....7/16" to 1-1/2"  
Depth of Cut.....2"  
Motor.....450 RPM, 8A  
Net Weight.....27.5 Lbs

### Commercial / Industrial Limited Warranty

Hougen Manufacturing, Incorporated warrants its Portable Magnetic Drills and its Electro-hydraulic Hole Punchers for a period of 1 year and other products for ninety (90) days from date of purchase against defects due to faulty material or workmanship and will repair or replace (at its option) without charge any items returned. This warranty is void if the item has been damaged by accident or unreasonable use, neglect, improper service, or other causes not arising out of defects in material or workmanship. No other expressed warranty is given or authorized. Hougen Manufacturing, Inc. disclaims any implied warranty of MERCHANTABILITY or FITNESS for any period beyond the expressed warranty and shall not be liable for incidental or consequential damages. Some states do not allow exclusions of incidental or consequential damages or limitation on how long an implied warranty lasts and, if the law of such a state governs your purchase, the above exclusion and limitation may not apply to you. This warranty gives you specific legal rights and you may also have other rights which vary from state to state.

To obtain warranty service, return the item(s), transportation prepaid, to your nearest Factory Authorized Warranty Repair Center or to Hougen Manufacturing, Inc., 3001 Hougen Drive, Swartz Creek, Michigan 48473.

Hougen Drills are warranted against manufacturing defects only. Subject to Hougen Manufacturing inspection.

THIS WARRANTY IS IN LIEU OF ANY OTHER WARRANTY, EXPRESSED OR IMPLIED, INCLUDING ANY WARRANTY OF MERCHANTABILITY OR FITNESS FOR A PARTICULAR PURPOSE.

© 2006 Hougen Manufacturing, Inc.

Photographs and Specifications shown are accurate in detail at time of printing. Manufacturer reserves the right to make improvements and modifications without prior notice.

Hougen, Rotabroach, and Hougen-Edge are proprietary trademarks of Hougen Manufacturing Inc.

# UNPACKING YOUR NEW MAGNETIC DRILL

1. Open shipping carton and remove the literature and hardware packages.
2. **Read and Follow All Instructions** before attempting to operate your new Magnetic Drill.
3. Complete and mail the Product Registration Card now. It is important that Hougen Manufacturing, Inc. have a record of product ownership.
4. Open hardware package and check contents.
  - 10565 1/8" Hex wrench for Gib Adjustment
  - 04558 Feed handles (3)
  - 04532 Feed handle knobs (3)
  - 10506 Set screw for cutter installation (2)
  - 10730 Safety chain
  - 02635 Hex wrench for cutter installation
  - 13013 5/32" Hex wrench
5. Using the handle of Magnetic Drill, lift unit out of the shipping case.
6. Remove all packing and securing material from the drill unit.
7. Screw the three Knobs (04532) into the three Feed Handles (04558) and then screw Handles into the Hub Assembly (40254). Do not overtighten or may strip the knobs.
8. Your Magnetic Drill was factory adjusted prior to shipping. Check to make sure that all gib adjustment screws, motor mount screws, front support bracket screws, and magnet mounting screws are snug and have not vibrated loose in transit.
9. Your new Magnetic Drill comes complete with arbor mounted. The 3/4" diameter arbor bore fits all 3/4"-shank "12,000-Series" Hougen Cutters.

**Reread Safety Warnings listed in the Operator's Manual and on the drill unit to avoid injury. Follow operating procedures.**

## INDEX

WELCOME TO HOUGEN	2	MOTOR PARTS	9
UNPACKING YOUR DRILL	3	WIRING DIAGRAM	10
SAFETY INSTRUCTIONS	4 - 5	ELECTRICAL PANEL PARTS	11
<b>SAFETY SWITCH INDICATOR LIGHT</b>	<b>5</b>	EXPLODED VIEW	12
OPERATING INSTRUCTIONS	6	PARTS LISTING	13
INSTALLING HOUGEN CUTTERS	7	DRILL MAINTENANCE & OPERATION HINTS	14
ARBOR & GIBS ADJUSTMENT	7	COMMERCIAL WARRANTY	15
MOTOR EXPLODED VIEW	8	WARRANTY SERVICE CENTERS	16

# SAFETY FIRST

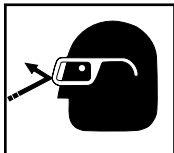

Always wear eye protection while using cutting tools, or in the vicinity of cutting.



**CAUTION!** Cutters are sharp. Wear gloves when installing or removing cutter from arbor. Do not grab a rotating cutter.



**CAUTION!** The slug is ejected at the end of the cut. Do not aim cutter or arbor so that ejected slug may hit someone around, or below you.



**CAUTION!** To prevent electric shock, do not use power tools near wet areas, or where power tool may become wet.

# Important Safety Instructions



**WARNING:** When using electric tools, basic safety precautions should always be followed to reduce the risk of fire, electric shock, and personal injury, including the following:

**1. Read All Instructions**

**2. Grounding Instructions**

This tool should be grounded while in use to protect the operator from electric shock. The tool is equipped with a 3-conductor cord and a 3-prong grounding type plug to fit the proper grounding type receptacle. The green (or green and yellow) conductor in the cord is the grounding wire. Never connect the green (or green and yellow) wire to a live terminal. (Refer to Plug Diagram) Section A

**3. Safe Electrical Connection**

Your Mag Drill is rated for use on 115VAC (Plug A) or 230V (Plug B) at 50-60Hz. Do not attempt to use drill on power sources rated other than this. Wet electrical connections are shock hazards. To prevent the cutting fluid from traveling along the cord and contacting the plug or power outlet, tie a drip loop in the power cord. Also elevate extension cords or gang box connections.

**4. Extension Cords**

Use only 3-wire extension cords that have 3-prong grounding type plugs and 3-pole receptacles that accept the tool's plug. Replace or repair damaged cords. Make sure the conductor size is large enough to prevent excessive voltage drop which will cause loss of power and possible motor damage.

**5. Do Not Force Tool**

It will do the job better and faster at the rate for which it was intended.

**6. Keep Work Area Clean**

Cluttered areas and benches invite injuries. Keep dirt and chips from under the Cutter area.

**7. Consider Work Area Environment**

Do not expose tool to rain.  
Do not use tool in damp or wet locations.  
Keep work area well lit.  
Do not use tool in presence of flammable liquids or gases. Disconnect from power source when changing cutters or maintaining drill.

**8. Guard Against Electric Shock**

Prevent body contact with grounded surfaces. For example: pipes, radiators, ranges, refrigerator enclosures.

**9. Keep Children Away**

Do not let visitors contact tool. All visitors should be kept away from work area while in use.

**10. Store Idle Tools**

When not in use, tools should be stored in a dry, and high or locked-up place — out of reach of children.

**11. Use Right Tool**

Do not force small tool or attachment to do the job of a heavy duty tool.  
Do not use tool for purpose not intended — for example — do not use a circular saw for cutting tree limbs or logs.

**Extension Cord Table**

LENGTH OF CORD, FEET	RECOMMENDED WIRE GAUGE	RECOMMENDED WIRE GAUGE
	115V MOTOR 10 - 12 AMPS	230 V MOTOR 5 - 6 AMPS
UP TO 25	16	18
26 - 50	14	18
51 - 100	10	16
101 - 200	8	14
201 - 300	6	12
301 - 500	4	10

**Plugs and Receptacles**

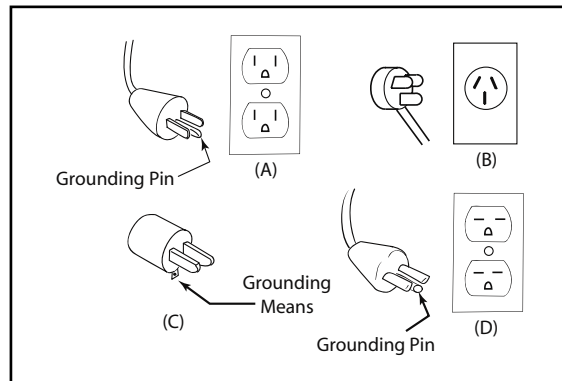

**12. Non-Conforming Cutting Tools**

Your Mag Drill is designed to use Houghn Cutters. The use of drilling tools having different shank styles is not recommended as they may not tighten securely in the drill arbor with risk of accident or injury.

**13. Secure Work**

Use clamps or a vise to hold work. It is safer than using your hand and it frees both hands to operate tool.

**14. Always Wear Safety Glasses or Goggles**

**15. Dress Properly**

Do not wear loose clothing or jewelry. They might entangle with spinning chips or get caught in moving parts. Rubber gloves and nonskid foot wear are recommended when working outdoors. Wear sturdy leather gloves when working indoors. Wear protective hair covering to contain long hair.

**16. Do Not Abuse Cord**

Never carry drill unit by its cord or yank it to disconnect from receptacle. Keep cord away from heat, oil, and sharp edges.

**17. Do Not Overreach**

Keep proper footing and balance at all time.

# Important Safety Instructions - Continued

## 18. Maintain Tools With Care

Keep tools sharp and clean for better and safer performance. Do not use dull or broken Hougén Cutters. Follow instructions for lubricating and changing accessories. Inspect tool cords periodically and, if damaged, have repaired by authorized service facility. Inspect extension cords periodically and, if damaged, have repaired by authorized service facility. Keep handles dry, clean, and free from oil and grease.

## 19. Disconnect Tools

Disconnect when not in use, before servicing, and when changing cutters or accessories.

## 20. Remove Adjusting Keys and Wrenches

Form a habit of checking to see that keys and wrenches are removed from tool before turning it on.

## 21. Check Damaged Parts

Before further use of the drill, a part that is damaged should be carefully checked to determine that it will operate properly and perform its intended function. Check for alignment of moving parts, binding of moving parts, breakage of parts, mounting, and any other conditions that may affect its operation. A part that is damaged should be properly repaired or replaced by an authorized service center unless otherwise indicated elsewhere in this operator manual. Do not operate tool if switch does not turn it on and off.

## 22. Stay Alert

Watch what you are doing and use common sense. Do not operate tool when you are tired. Have defective switches replaced by authorized service center.

## 23. Outdoor Use Extension Cords

When tool is used outdoors, use only extension cords intended for use outdoors and so marked.

## 24. Additional Safety Precautions

Arbor and cutter should never be used as a hand-hold. Keep hands and clothing away from all moving parts. Do not use Hougén Cutters where ejected slug might cause injury (slug ejected at end of cut). Also, adhere to all operating instructions. Do not drill through any surface that may contain live electrical wiring. Drilling into a live wire could cause exposed metal parts of the drill to be made live. Remove chips wrapped around Cutter and arbor after each hole. With motor off and power disconnected, grasp chips with leather gloved hand or pliers and pull while rotating counterclockwise. Should the cutter become jammed in the work, stop the unit immediately to prevent personal injury. Disconnect the drill from the power supply and loosen jammed cutter by turning the arbor counterclockwise. Never attempt to free the jammed cutter by starting the motor. Service at authorized repair center only.

## 25. Operating Near Welding Equipment

DO NOT operate this unit on the same work surface that welding is being performed on. Severe damage to the unit, particularly the power cord, could occur. This could also result in personal injury to the operator.

## 26. Circuit Breaker

Changing of the circuit breaker to a higher amp rated breaker, or bypassing the circuit breaker is not recommended and will void product warranty.

## 27. Circuit Breaker Operation

The circuit breaker is a thermal breaker. When it reaches the higher temperature rating it will trip and cause the unit to shut down. This is a protective device and can be reset after 5 to 10. To reset the breaker, press the breaker button back in. If it does not reset, let the unit cool a little longer until you can push the button in and it stays in position.

## 28. Safe Electrical Connection

Wet electrical connections are shock hazards. To prevent the cutting fluid from traveling along the cord and contacting the plug or power outlet, tie a drip loop as shown. Also elevate extension cords or gang box connections.

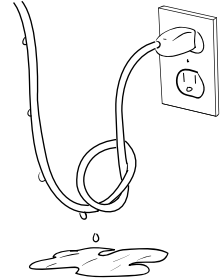

## 29. Save these Instructions.

## SAFETY SWITCH INDICATOR LIGHT

The Safety Switch Indicator Light is a Standard Safety Feature on HMD904 magnetic drills. Its purpose is to inform the user that an unsafe condition exists.

### If light is Green:

In normal operation the safety switch light will be green. Motor "On" and "Off" Switches function normally.

### If light is Red:

A condition with the safety switch exists that needs to be corrected.

#### Possible causes:

- Safety Switch is defective. Have drill serviced.
- Uneven work surface or material. Check work surface for flatness.
- Dirt or chips under magnet. Clean work surface.
- Too thin material. Make sure material is at least 3/8" thick.

**HOUGEN MANUFACTURING RECOMMENDS THAT CONDITIONS ARE CORRECTED SO LIGHT TURNS GREEN. THIS ALLOWS FOR THE UNIT TO BE OPERATED IN A SAFE MANNER.**

When light is Red the motor will still function, but "ON" switch becomes a momentary switch. (The switch must be held down to operate motor.)

For any questions please contact Hougén Manufacturing's Technical Service at (810) 635-7111.

# OPERATION OF CONTROLS BEFORE INSTALLING HOUGEN CUTTER

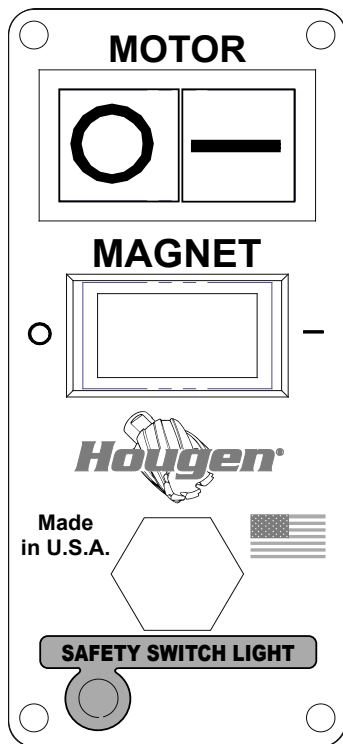

CONTROL PANEL SWITCH PLATE  
FIGURE 2

**IMPORTANT:** Before turning on the machine, it is important that the operator understands the interrelated functions of the SAFETY SWITCH, MAGNET SWITCH, AND MOTOR SWITCH.

*READ SAFETY SWITCH INDICATOR LIGHT INSTRUCTIONS ON PREVIOUS PAGE.*

**SAFETY SWITCH** — Located in base of drill. Enables motor operation only when magnet is properly seated on a clean and flat work surface. Turns motor off if switch detects lift of unit.

**MAGNET ON/OFF SWITCH** — Energizes and De-energizes the magnetic base and activates the safety switch. Motor can now be started by pushing the motor START switch.

**MOTOR START/STOP SWITCH** — Starts and stops the motor (See instructions previous page).

1. Place Magnetic Drill on clean, flat steel plate that is at least 3/8" thick.
2. Plug unit into proper AC power source. **DO NOT use with DC Power.**
3. Locate the Magnet **ON** and **OFF** switch and the motor **STOP** and **START** switch (Fig. 2).
4. **NOTE: A loss of power will de-energize the magnetic base and deactivate the motor. When power is restored, the magnet will reenergize, however, the motor START switch must be depressed before the motor will start.**

## OPERATING INSTRUCTIONS

Always remember that the magnet's holding power is directly related to the workpiece thickness and surface condition. Since magnetic attraction diminishes with thinner material or rough surfaces, mechanical clamping of drill unit to the workpiece should be used when cutting thin material (3/8" or less) or material with uneven surfaces.

1. Make sure workpiece and bottom of magnet are free of chips, oil, etc.
2. Position drill by sliding it and gently feeding Arbor so that pilot point is touching center of hole to be drilled.
3. **Secure unit to workpiece with safety chain.**
4. Turn magnet ON by pressing the magnet ON switch.
5. Turn Feed Handle, raising the cutter until the pilot is above the work surface.
6. Make certain that cutter is clear of workpiece and turn motor ON by pressing the motor START switch.
7. Feed Hougen Cutter slowly into workpiece. Only after cutting path is established to a depth of about 1/16" can full force be applied to feed handles.
8. Ease up on feed pressure as cutter starts breaking through.
9. At conclusion of cut, turn motor OFF by pressing motor STOP switch. Turn Feed Handles to raise Arbor thereby ejecting the slug if it hasn't already fallen free.
10. Turn magnet OFF by pressing the magnet OFF switch.
11. **Disconnect from power source.**
12. If necessary, remove chips from cutter and magnet, preferably wearing leather work gloves and/or with pliers. Disconnect safety chain and you are ready to move unit to new drilling position.

## INSTALLING HOUGEN CUTTER IN ARBOR

1. Disconnect from power source.
2. Lay drill on its side with feed handles up or be sure Arbor clears table if unit is in normal operating position.
3. Turn Feed Handles until cutter mounting set screws are exposed and completely remove the set screws.
4. Insert proper pilot in shank end of Hougen Cutter.
5. Insert Hougen Cutter until flat on cutter shank is aligned with set screw holes and is exactly perpendicular to axis of set screw holes.
6. Insert set screws and tighten. Check to be certain that cutter is secure.

## OPERATION OF CUTTING FLUID RESERVOIR

1. With Magnetic Drill in operating position, turn the feed handles so that cutter and pilot are above the work surface.
2. With magnet turned ON and motor OFF, fill reservoir by introducing cutting fluid through slots in Arbor.  
**Cutting fluid should not leak out.**
3. Test metering capabilities of Arbor/Cutter/Pilot assembly (magnet ON-motor OFF) by feeding the Arbor gently toward work surface until pilot is pushed up into Cutter, thus allowing fluid to filter down onto work surface through groove in pilot.
4. For proper lubrication, all cutting fluid in reservoir should empty onto work surface in no less than 15 seconds and no longer than 30 seconds.

## ADJUSTMENT OF GIBS

1. Loosen all Gib Screws (40237).
  2. Feed the drill in and out a few times and then, with top of motor slide flush with top of housing, tighten the Gib Screws until you feel them touch the Steel Gib (02431).
  3. Feed the drill in and out again.
  4. Adjust Gib Screws so that there is uniform pressure from top to bottom. (Top of motor slide flush with top of housing.)
  5. Turn each Gib Screw in about 1/8 to 1/4 turn, depending upon your preference.
  6. Gibs should be tight enough so that slide moves up and down smoothly with no wobble or shaking. (Looseness will cause cutter breakage.)
- NOTE: Gibs should be lubricated regularly.**

## ARBOR & FRONT SUPPORT BRACKET REMOVAL AND INSTALLATION

### Removal

1. Loosen arbor support bracket bolts.
2. Loosen set screws holding arbor onto motor output shaft.
3. Remove arbor.

### Installation

1. Hand tighten front support bracket bolts. Do not tighten all the way.
2. Slide arbor to full up position and hold arbor in position over hex drive motor output shaft.
3. Tighten two set screws to hold arbor onto motor output shaft.
4. Turn feed handle until motor and arbor are at the bottom of their travel.
5. Tighten front support bracket bolts to 400 in/lbs.
6. Run motor for 10 seconds. (If visual movement of arbor is noticed, restart at step 1)
7. Re-check for tightness of arbor set screws.

## ARBOR ADJUSTMENT

**Adjust Gibs before adjusting front support bracket.**

1. Loosen Arbor Support Bracket Bolts.
2. Be sure top of arbor is flush with the shoulder on motor output shaft. Also make certain arbor is securely fastened.
3. Turn feed handle until motor and spindle are at the bottom of their travel.
4. Tighten Arbor Support Bolts.
5. Feed slide up and down a few times, checking for free and uniform movement.

**NOTE: Check Arbor support bolts regularly to make certain they are tight. Tighten as required.**

# MOTOR PARTS DIAGRAM

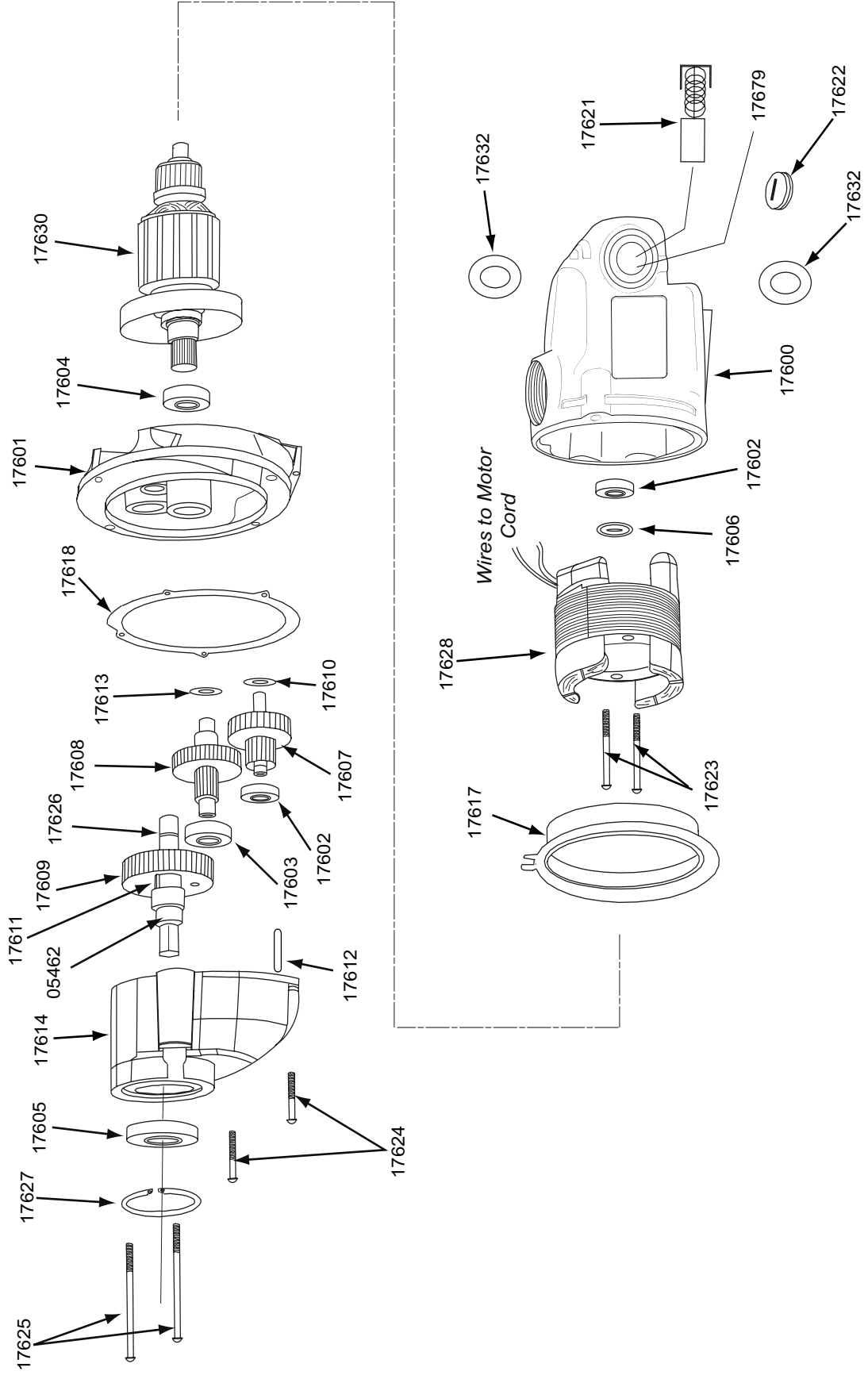



# MOTOR ASSEMBLY

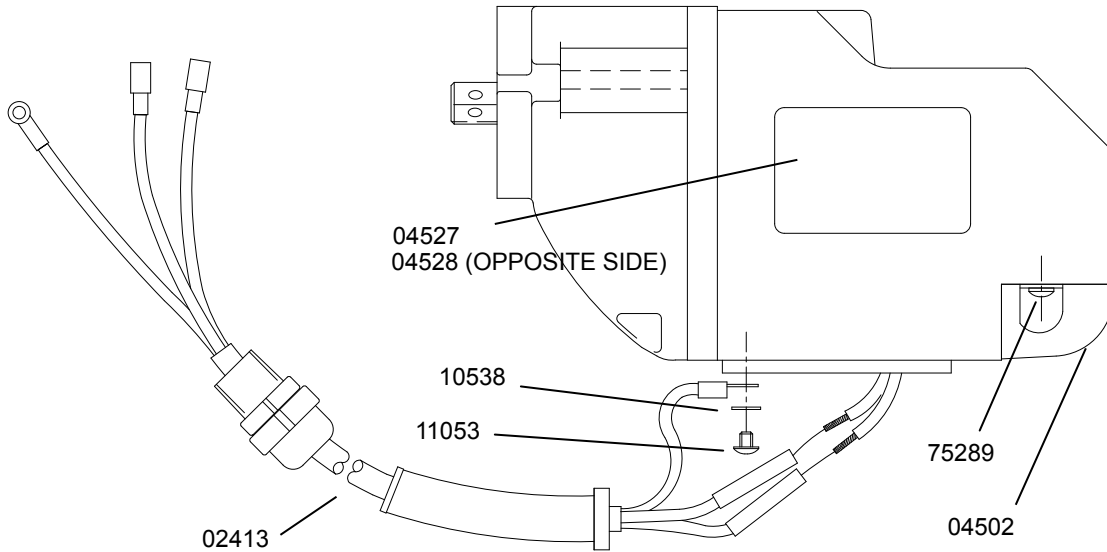

11053 BOLT TORQUE SPECIFICATIONS - TIGHTEN TO 18 IN-LBS  
 75289 BOLT TORQUE SPECIFICATIONS - TIGHTEN TO 25 IN-LBS

## MOTOR PARTS LIST - 05477

Part #	Description	Qty	Part #	Description	Qty
02413	Motor Cord	1	17611	Key	1
04502	Brush Cover	1	17612	Dowel Pin	1
04527	Label, Motor Specs	1	17613	Flat Washer	1
04528	Label, Motor Safety	1	17614	Gear Housing	1
05462	Spindle	1	17617	Fan Guide	1
10538	Washer #8	1	17618	Gasket	1
11053	Screw BHS #8-32	1	17630	Armature	1
17600	Field Case	1	17628	Field	1
17601	Gear Housing	1	17621	Carbon Brush (Pack of 2)	1
17602	Ball Bearing	2	17622	Brush Cap	2
17603	Ball Bearing	1	17623	Pan Head Screw	2
17604	Ball Bearing	1	17624	Pan Head Screw Short	2
17605	Ball Bearing	1	17625	Pan Head Screw Long	2
17606	Dust Seal	1	17626	Retaining Ring	1
17607	1st Inter. Gear Assy	1	17627	Retaining Ring	1
17608	2nd Inter. Gear Assy	1	17632	Paper Washer	2
17609	Spur Gear	1	17679	Brush Holder	2
17610	Flat Washer	1	75289	Pan Head Screw	2

# CONTROL PANEL HOOKUP

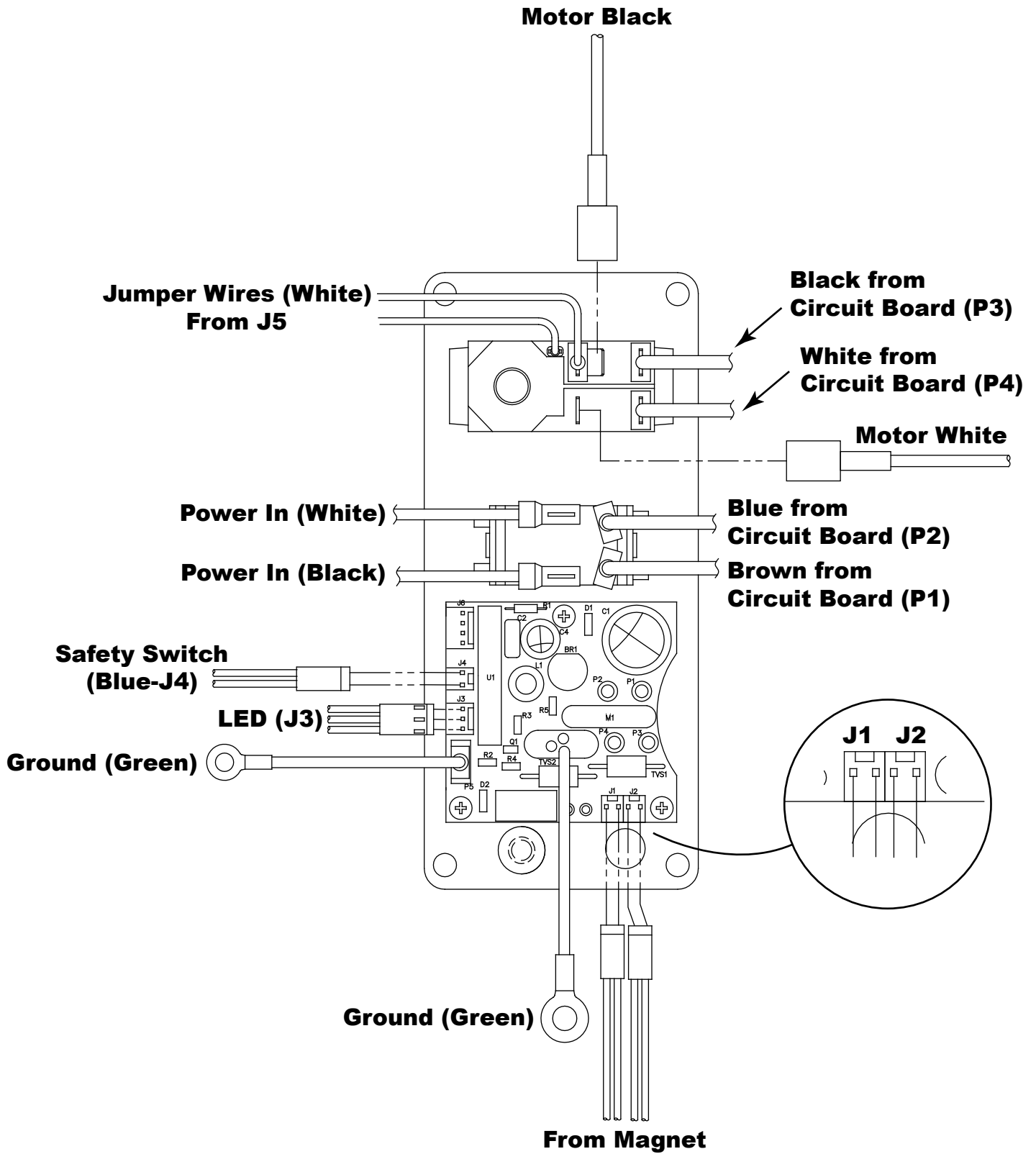

# CONTROL PANEL PARTS LIST

## Panel Assembly P/N: 05188

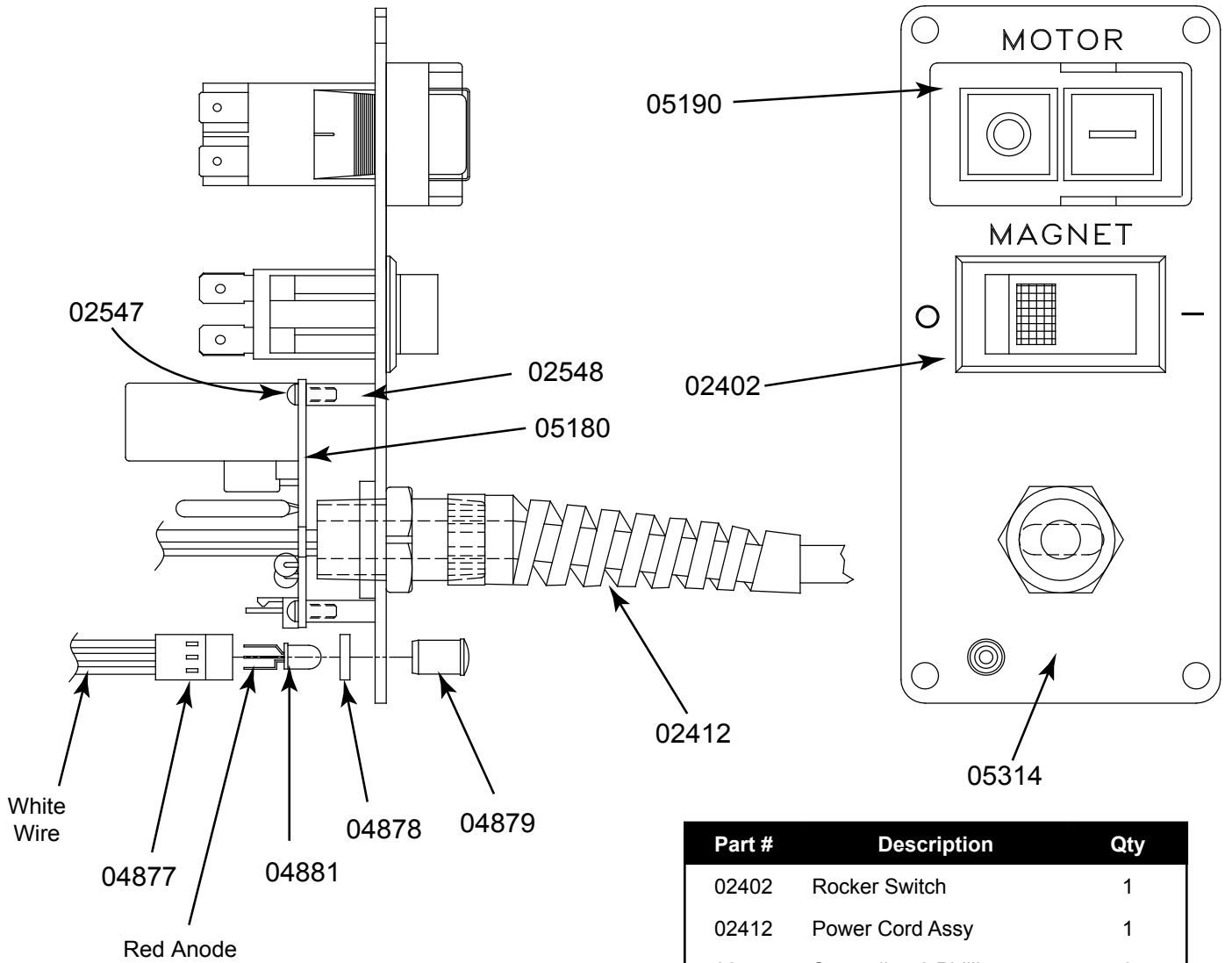

Note: When inserting LED into wiring harness make sure red anode lines up with white wire

Part #	Description	Qty
02402	Rocker Switch	1
02412	Power Cord Assy	1
02547	Screw #4-40 Phillips	3
02548	Spacer	3
04877	Wire Harness LED	1
04878	Spacer	1
04879	LED Lens	1
04881	LED	1
05180	Circuit Board	1
05190	On/Off Switch	1
05204*	Jumper Wire Harness	1
05205*	Ground Wire Harness	1
05314	Faceplate	1
* Not Shown		

# MODEL HMD904 EXPLODED DIAGRAM

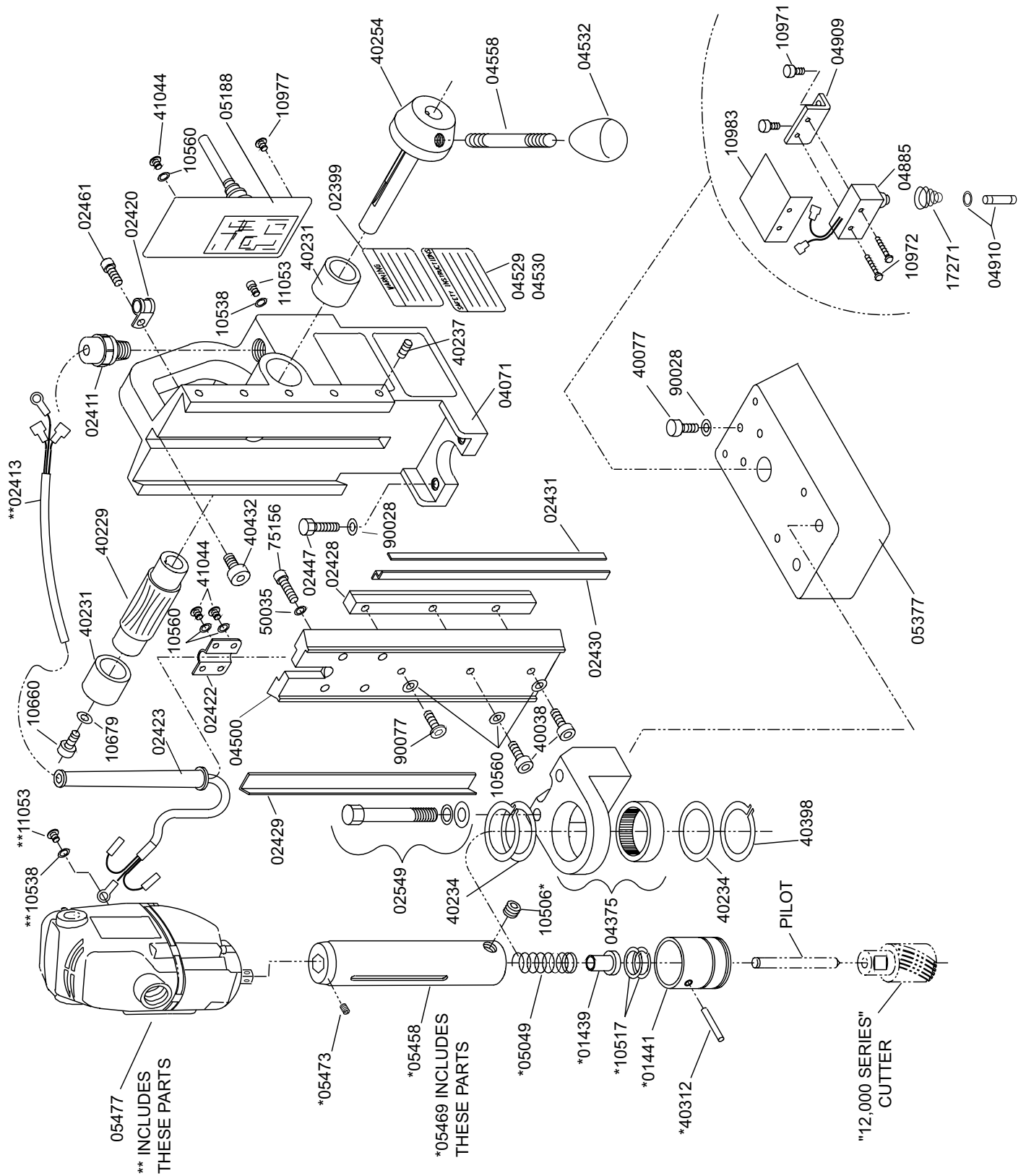

# HMD904 PARTS LIST

Part #	Description	Qty	Part #	Description	Qty
02411	Strain Relief-Motor Cord	1	40234	Thrust Washer	2
02413	Motor Cord	1	40254	Hub Assy	1
02420	Motor Cord Clamp	1	40398	Retaining Ring	1
02421	Glide Post Spring	2	40432	Screw SHC 1/4-28	1
02422	Motor Cord Bracket	1	41044	Screw BHC #10-32	6
02423	Motor Cord Flex Prot.	1	50035	Lock Washer 1/4 Ext	4
02428	Rack Gear	1	90028	Lock Washer 1/4 Heli	3
02429	Brass Gib - Right	1	90052	Lock Washer #6 Ext	1
02430	Brass Gib - Left	1	90077	Screw BHC #10-32 x 1/2	1
02431	Steel Gib	1			
02447	Bolt-Hex Head 1/4-28	2		<b>Assemblies</b>	
02461	Screw BHC 1/4-20 x 3/8	2	<b>05477</b>	<b>Motor Assy</b>	
04375	Front Support Bracket	1	<b>04541</b>	<b>Housing Assy</b>	
04500	Motor Mount Slide	1	04529	Safety Label	1
04532	Feed Handle Knob	3	04530	Warning Label	2
04558	Feed Handle	3	04553	Warning Label Chain	1
04885	Safety Switch Assy	1	40231	Bronze Bushing	2
04909	Safety Switch Bracket	1	40229	Feed Gear	1
04910	Plunger Assy	1	40237	Gib Screws	5
05377	Magnet	1	<b>05469</b>	<b>Arbor Assembly</b>	
10538	Lock Washer	1	01441	Ejector Spring	1
10560	Lock Washer	11	01439	Seat Spring	1
10660	Screw SHC 1/4-20 x 5/8	1	05049	Arbor Spring	1
10679	1/4" Flat Washer	1	05458	Arbor Body	1
10971	Screw SHC 1/4-20	2	05473	Set Screws	2
10972	Screw BHC #6-32	2	10506	SCR-Set 3/8-24 SPL	2
10973	Nut	2	10517	Retaining Ring	2
10977	Screw BHC 1/4-20	1	40312	Roll Pin Altered	1
10983	Safety Switch Shield	1	<b>02549</b>	<b>Bolt Kit Assembly</b>	
11053	Screw BHC #8-32	1	02460	Bolt Hex 3/8-24 x 2-3/4	2
17271	Taper Spring	1	40391	Lock Washer 3/8 Heli	2
40038	Screw SHC #10-32	2	40392	Washer Flat 3/8	2
40077	Screw SHC 1/4-20	1	<b>05188</b>	<b>Control Panel Assy</b>	
40214	Screw SHC #6-32	1			

# MAINTENANCE

In order to minimize wear on moving parts and to insure smoother operation and longer life for your magnetic drill, the following maintenance should be done periodically, based on use.

1. Regularly tighten all fasteners and replace all worn parts.
2. Check motor brushes and replace if worn. (Break in period - 30 minutes at no load speed)
3. Check power cord and cord from panel to motor and, if cracked or frayed, return to an authorized repair center for replacement.
4. Apply grease to the slide dovetails, brass gibs, and the feed gear rack. For best results use Shell Cyprina-RA or equivalent.
5. Remove arbor and pack the bearing in the front support bracket with grease. Use Shell Cyprina-RA or equivalent.

# HINTS FOR SMOOTHER OPERATION

1. Keep insides of Hougen Cutter clear of chips. Chips will interfere with cutting to maximum depth, may impede the free oil flow and can cause cutter breakage.
2. Keep work, machine, arbor and Hougen Cutter free of chips and dirt.
3. Tighten all bolts and fasteners regularly.
4. We highly recommend using a light viscosity cutting fluid (preferably Hougen Cutting Fluid - Part No. 11742-4)
5. Occasionally check metering of cutting fluid flow. Lack of cutting fluid may cause Hougen Cutter to freeze in cut, slug to stick and may result in poor cutter life.
6. Always start cut with light feed pressure and then increase sufficiently to achieve maximum cutting rate.
7. Ease off on pressure as cutter begins to break through at the end of the cut.
8. Keep slide dovetails, brass gibs and feed rack lubricated and free of chips and dirt.
9. When slug hangs up in cutter, turn off motor and bring cutter down on a flat surface. This will normally straighten a cocked slug, allowing it to be ejected.
10. When cutting large diameter or deep holes it may be necessary to stop in the middle of the cut to add cutting fluid and remove the chips from around the arbor. (When doing this DO NOT raise the cutter out of the hole. Doing so can allow chips to get under the teeth of the cutter and make it difficult to restart the cut.)

**#1 cause of cutter breakage and prematurely dull teeth is too little feed pressure\***

**\* "Babying" the cutter through the cut will only decrease tool life.**

# REMEDIES FOR HOLEMAKING PROBLEMS

- 1. Trouble: Magnetic base won't hold effectively to work.**
    - a. Cause: Chips or dirt under magnet.  
*Remedy:* Clear area of chips and dirt.
    - b. Cause: Irregular surface on bottom of magnet or on workpiece.  
*Remedy:* Lightly surface grind the bottom of the magnet flat and/or file imperfections flat on the work surface as needed.
  - 2. Trouble: Cutter tends to move across surface of work.**
    - a. Cause: Magnetic base not holding effectively.  
*Remedy:* See causes and remedies under No. 1 above.
    - b. Cause: Too much feed pressure at start of cut.  
*Remedy:* Light pressure until a groove is cut. The groove then serves as a stabilizer.
    - c. Cause: Worn pilot.  
*Remedy:* Replace pilot
  - 3. Trouble: Out of round holes.**
    - a. Cause: Worn arbor support bracket bearing and or ejector collar.  
*Remedy:* Replace: (only a few thousandths wear permissible.)
    - b. Cause: Misaligned support bracket  
*Remedy:* Realign support bracket
    - c. Cause: Misaligned or loose arbor set screws.  
*Remedy:* Tighten set screws.
  - 4. Trouble: Motor and slide won't stay in set position**
    - a. Cause: Gibs too loose  
*Remedy:* Adjust gibs
  - 5. Trouble: Erratic or intermittent feed.**
    - a. Cause: Worn or pinion and/or rack.  
*Remedy:* Replace worn parts.
  - 6. Trouble: Motor doesn't run when motor START button is pushed.**
    - a. Cause: Magnet is not turned on  
*Remedy:* Push magnet ON button.
    - b. Cause: Magnet on rough or dirty work surface and safety switch not fully depressed.  
*Remedy:* File work surface flat and clean all chips and oil from under magnet.
    - c. Cause: No power  
*Remedy:* Check power source and extension cords.
    - e. Cause: Worn motor brushes  
*Remedy:* Replace brushes
    - f. Cause: Faulty motor START switch  
*Remedy:* Return unit to an authorized repair center to have switch replaced.
- NOTE: If you are unable to correct any malfunction after trying the above, do not attempt to operate the drill. Return the unit to the factory or authorized repair center for service.**

## OPTIONAL COOLANT BOTTLE

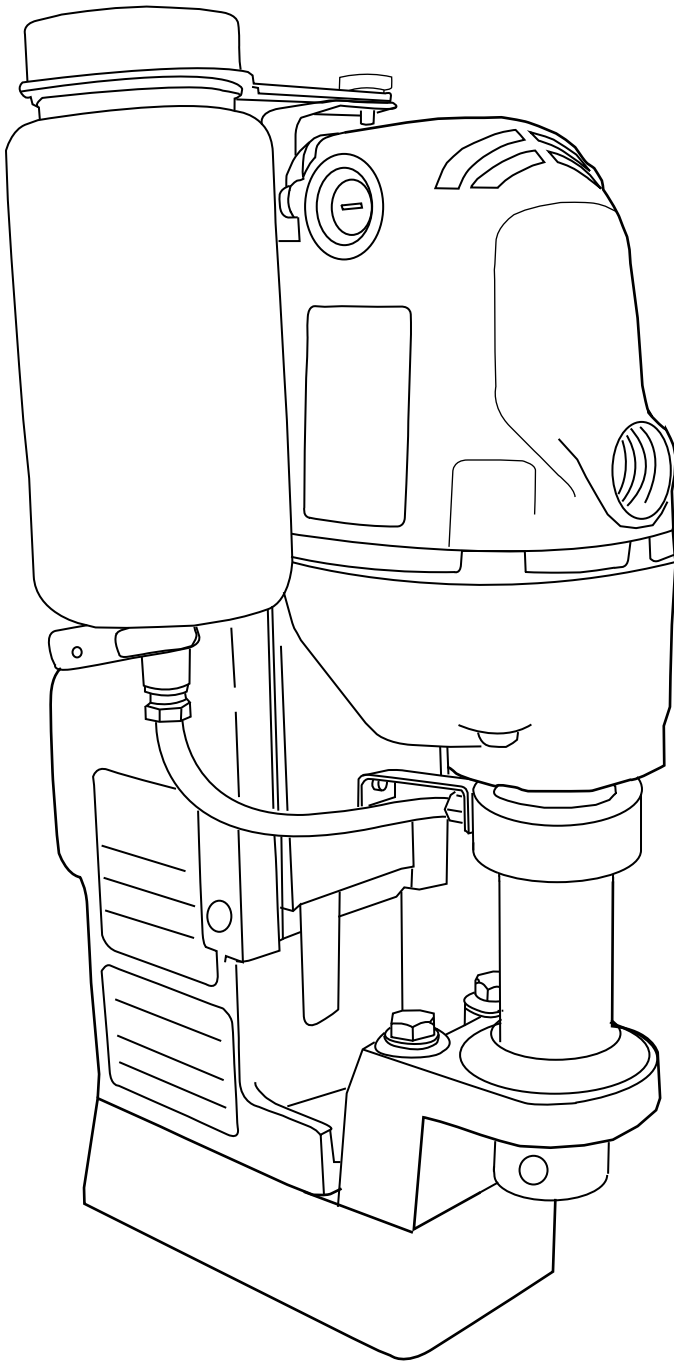

**Now Available for  
the HMD904 is a  
Coolant Bottle  
and Arbor System**

**Part No. 05548**

**The new coolant bottle  
attachment makes  
repetitive holmaking more  
productive and saves time.  
The kit comes complete  
with bottle, new arbor, and  
step-by-step instructions.**