

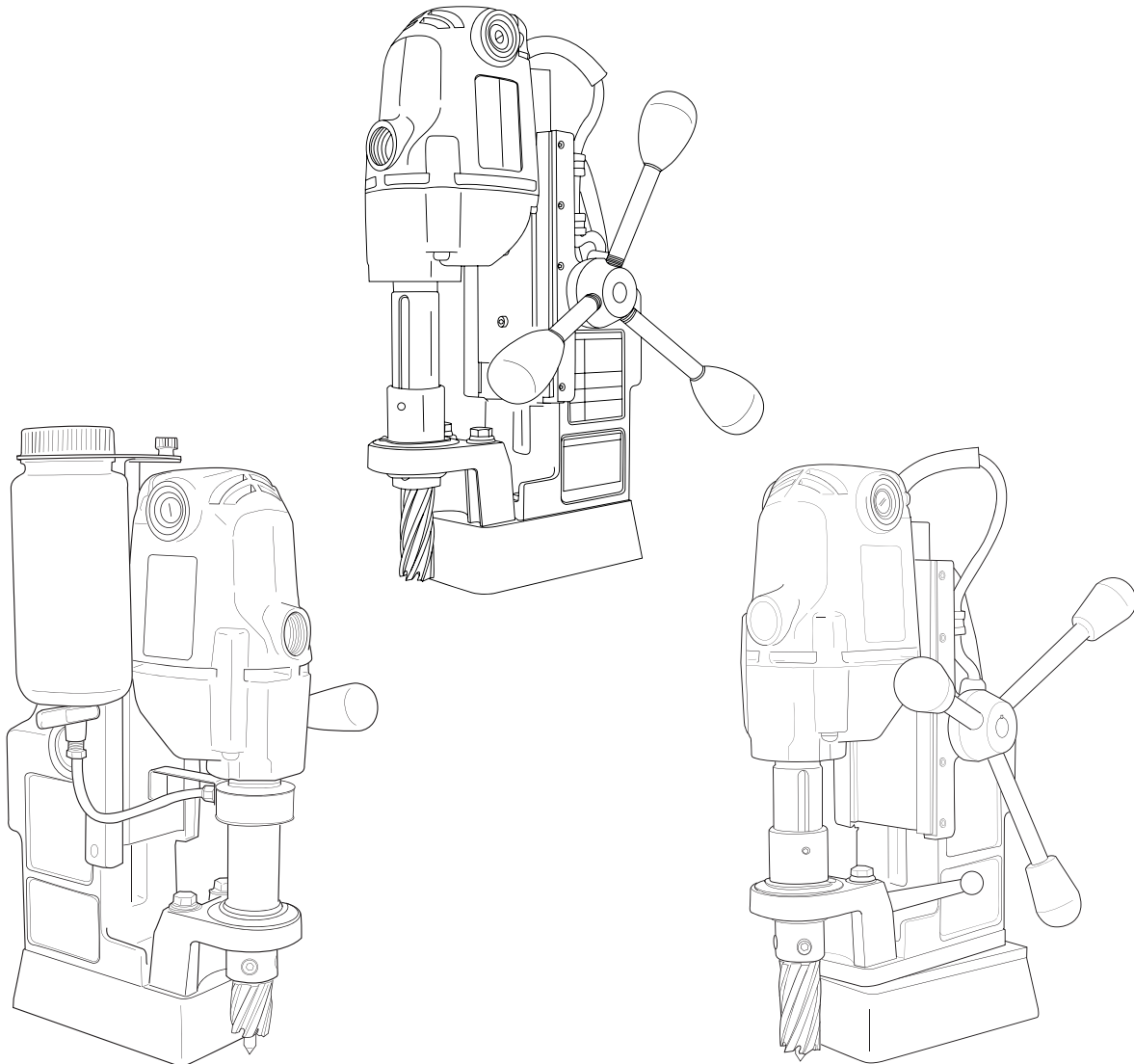

HMD908 SERIES PORTABLE MAGNETIC DRILLS OPERATOR'S MANUAL



FOR USE WITH "12,000-SERIES" HOUGEN[®] CUTTERS

HOUGEN®

Portable Magnetic Drills

HMD908 Series

Welcome to Hougen

Congratulations on your purchase of the Hougen® Portable Magnetic Drill. Your model is designed to produce superior holes quickly and efficiently. Through constant innovation and development, Hougen is committed to provide you with hole-producing tools and products to help you be more productive.

Before attempting to operate your new Portable Magnetic Drill, please read all instructions first. These include the Operator's Manual and Warning Label on the unit itself. With proper use, care, and maintenance, your model will provide you with years of effective hole drilling performance. Once again, thank you for selecting our product and welcome to Hougen.

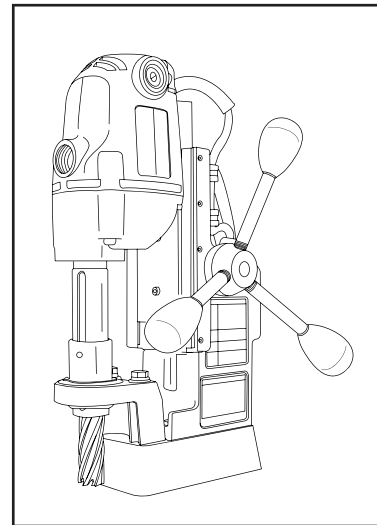

Specifications

Cutter Type.....	Hougen "12,000-Series"
Hole Capacity.....	12mm to 38 mm
Depth of Cut.....	50 mm
Motor.....	450 RPM, 4A
Net Weight.....	12.5 kg
Swivel Area	28.5mm W x 35mm L

COM. / IND. LIMITED WARRANTY

Hougen Manufacturing, Incorporated warrants its Portable Magnetic Drills, Electro-hydraulic Hole Punchers, and Tornado II Paint Shaker for one (1) year and its and other products for ninety (90) days from date of purchase against defects due to faulty material or workmanship and will repair or replace (at its option) without charge any items returned. This warranty is void if the item has been damaged by accident or unreasonable use, neglect, improper service, or other causes not arising out of defects in material or workmanship. No other expressed warranty is given or authorized. Hougen Manufacturing, Inc. disclaims any implied warranty of MERCHANTABILITY or FITNESS for any period beyond the expressed warranty and shall not be liable for incidental or consequential damages. Some states do not allow exclusions of incidental or consequential damages or limitation on how long an implied warranty lasts and, if the law of such a state governs your purchase, the above exclusion and limitation may not apply to you. This warranty gives you specific legal rights and you may also have other rights which vary from state to state.

To obtain warranty service, return the item(s), transportation prepaid, to your nearest Factory Authorized Warranty Repair Center or to Hougen Manufacturing, Inc., 3001 Hougen Drive, Swartz Creek, Michigan 48473.

Hougen Drills are warranted against manufacturing defects only. Subject to Hougen Manufacturing inspection.

THIS WARRANTY IS IN LIEU OF ANY OTHER WARRANTY, EXPRESSED OR IMPLIED, INCLUDING ANY WARRANTY OF MERCHANTABILITY OR FITNESS FOR A PARTICULAR PURPOSE.

© 2008 Hougen Manufacturing, Inc.

HOUGEN PATENT NOTICE

The products in this manual may be covered by one or more of the following U.S. patents, foreign patents, and pending patents:

5902076

Photographs and Specifications shown are accurate in detail at time of printing. Manufacturer reserves the right to make improvements and modifications without prior notice.

Hougen and Punch-Pro are proprietary trademarks of Hougen Manufacturing, Inc.

Ogura and the Ogura logo are proprietary trademarks of Ogura & Co., Ltd. Vac-Pad is a proprietary trademarks of Drillmate PTY, Ltd.

UNPACKING YOUR NEW MAGNETIC DRILL

1. Open shipping carton and remove the literature and hardware packages.
2. **Read and Follow All Instructions** before attempting to operate your new Magnetic Drill.
3. Complete and mail the Product Registration Card now. It is important that Hougen Manufacturing, Inc. have a record of product ownership.
4. Open hardware package and check contents.
 - 10565 1/8" Hex wrench for Gib Adjustment
 - 04558 Feed handles (3)
 - 04532 Feed handle knobs (3)
 - 10506 Set screw for cutter installation (2)
 - 10730 Safety chain
 - 02635 Hex wrench for cutter installation
 - 13013 5/32" Hex wrench
5. Using the handle of Magnetic Drill, lift unit out of the shipping case.
6. Remove all packing and securing material from the drill unit.
7. Screw the three Knobs (04532) into the three Feed Handles (04558) and then screw Handles into the Hub Assembly (40254).
8. Your Magnetic Drill was factory adjusted prior to shipping. Check to make sure that all gib adjustment screws, motor mount screws, front support bracket screws, and magnet mounting screws are snug and have not vibrated loose in transit.
9. Your new Magnetic Drill comes complete with arbor mounted. The 3/4" diameter arbor bore fits all 3/4"-shank "12,000-Series" Hougen Cutters.

Reread Safety Warnings listed in the Operator's Manual and on the drill unit to avoid injury. Follow operating procedures.

INDEX

WELCOME TO HOUGEN	2	CONTROL PANEL HOOK-UP	13
UNPACKING YOUR DRILL	3	CONTROL PANEL PARTS LIST	14
SAFETY INSTRUCTIONS	4 - 5	HMD908 EXPLODED VIEW	16
SAFETY SWITCH INDICATOR LIGHT	5	PARTS LISTING	17
OPERATING INSTRUCTIONS	6	HMD908C EXPLODED VIEW	18
INSTALLING HOUGEN CUTTERS	7	PARTS LISTING	19
ARBOR & GIBS ADJUSTMENT	7	HMD908S EXPLODED VIEW	20
MAINTENANCE, HINTS REMEDIES	8	PARTS LISTING	21
COOLANT BOTTLE	9	HMD908SC EXPLODED VIEW	22
SWIVEL ADJUSTMENTS	10	PARTS LISTING	23
MOTOR BREAKDOWN	11	WARRANTY SERVICE CENTERS	24
MOTOR PARTS LIST	12		

SAFETY FIRST

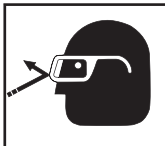

Always wear eye protection while using cutting tools, or in the vicinity of cutting.



CAUTION! Cutters are sharp. Wear gloves when installing or removing cutter from arbor. Do not grab a rotating cutter.



CAUTION! The slug is ejected at the end of the cut. Do not aim cutter or arbor so that ejected slug may hit someone around, or below you.



CAUTION! To prevent electric shock, do not use power tools near wet areas, or where power tool may become wet.

Important Safety Instructions



WARNING: When using electric tools, basic safety precautions should always be followed to reduce the risk of fire, electric shock, and personal injury, including the following:

1. Read All Instructions

2. Grounding Instructions

This tool should be grounded while in use to protect the operator from electric shock. The tool is equipped with a 3-conductor cord and a 3-prong grounding type plug to fit the proper grounding type receptacle. The green (or green and yellow) conductor in the cord is the grounding wire. Never connect the green (or green and yellow) wire to a live terminal. (Refer to Plug Diagram) Section A

3. Safe Electrical Connection

Your Mag Drill is rated for use on 115VAC (Plug A) or 230V (Plug B) at 50-60Hz. Do not attempt to use drill on power sources rated other than this. Wet electrical connections are shock hazards. To prevent the cutting fluid from traveling along the cord and contacting the plug or power outlet, tie a drip loop in the power cord. Also elevate extension cords or gang box connections.

4. Extension Cords

Use only 3-wire extension cords that have 3-prong grounding type plugs and 3-pole receptacles that accept the tool's plug. Replace or repair damaged cords. Make sure the conductor size is large enough to prevent excessive voltage drop which will cause loss of power and possible motor damage.

5. Do Not Force Tool

It will do the job better and faster at the rate for which it was intended.

6. Keep Work Area Clean

Cluttered areas and benches invite injuries. Keep dirt and chips from under the Cutter area.

7. Consider Work Area Environment

Do not expose tool to rain.
Do not use tool in damp or wet locations.
Keep work area well lit.
Do not use tool in presence of flammable liquids or gases. Disconnect from power source when changing cutters or maintaining drill.

8. Guard Against Electric Shock

Prevent body contact with grounded surfaces. For example: pipes, radiators, ranges, refrigerator enclosures.

9. Keep Children Away

Do not let visitors contact tool. All visitors should be kept away from work area while in use.

10. Store Idle Tools

When not in use, tools should be stored in a dry, and high or locked-up place — out of reach of children.

11. Use Right Tool

Do not force small tool or attachment to do the job of a heavy duty tool.
Do not use tool for purpose not intended — for example — do not use a circular saw for cutting tree limbs or logs.

Extension Cord Table

LENGTH OF CORD, FEET	RECOMMENDED WIRE GAUGE	RECOMMENDED WIRE GAUGE
	115V MOTOR 10 - 12 AMPS	230 V MOTOR 5 - 6 AMPS
UP TO 25	16	18
26 - 50	14	18
51 - 100	10	16
101 - 200	8	14
201 - 300	6	12
301 - 500	4	10

Plugs and Receptacles

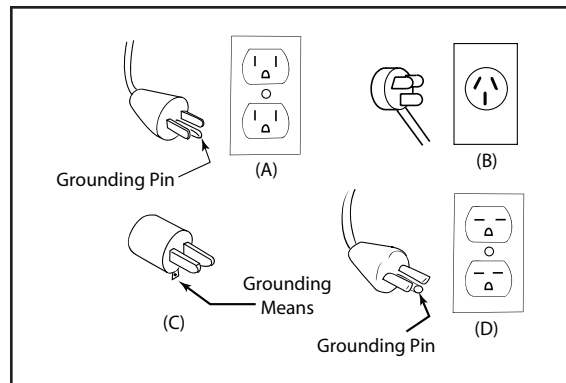

12. Non-Conforming Cutting Tools

Your Mag Drill is designed to use Houghen Cutters. The use of drilling tools having different shank styles is not recommended as they may not tighten securely in the drill arbor with risk of accident or injury.

13. Secure Work

Use clamps or a vise to hold work. It is safer than using your hand and it frees both hands to operate tool.

14. Always Wear Safety Glasses or Goggles

15. Dress Properly

Do not wear loose clothing or jewelry. They might entangle with spinning chips or get caught in moving parts. Rubber gloves and nonskid foot wear are recommended when working outdoors. Wear sturdy leather gloves when working indoors. Wear protective hair covering to contain long hair.

16. Do Not Abuse Cord

Never carry drill unit by its cord or yank it to disconnect from receptacle. Keep cord away from heat, oil, and sharp edges.

17. Do Not Overreach

Keep proper footing and balance at all time.

Important Safety Instructions - Continued

18. Maintain Tools With Care

Keep tools sharp and clean for better and safer performance. Do not use dull or broken Hougén Cutters. Follow instructions for lubricating and changing accessories. Inspect tool cords periodically and, if damaged, have repaired by authorized service facility. Inspect extension cords periodically and, if damaged, have repaired by authorized service facility. Keep handles dry, clean, and free from oil and grease.

19. Disconnect Tools

Disconnect when not in use, before servicing, and when changing cutters or accessories.

20. Remove Adjusting Keys and Wrenches

Form a habit of checking to see that keys and wrenches are removed from tool before turning it on.

21. Check Damaged Parts

Before further use of the drill, a part that is damaged should be carefully checked to determine that it will operate properly and perform its intended function. Check for alignment of moving parts, binding of moving parts, breakage of parts, mounting, and any other conditions that may affect its operation. A part that is damaged should be properly repaired or replaced by an authorized service center unless otherwise indicated elsewhere in this operator manual. Do not operate tool if switch does not turn it on and off.

22. Stay Alert

Watch what you are doing and use common sense. Do not operate tool when you are tired. Have defective switches replaced by authorized service center.

23. Outdoor Use Extension Cords

When tool is used outdoors, use only extension cords intended for use outdoors and so marked.

24. Additional Safety Precautions

Arbor and cutter should never be used as a hand-hold. Keep hands and clothing away from all moving parts. Do not use Hougén Cutters where ejected slug might cause injury (slug ejected at end of cut). Also, adhere to all operating instructions. Do not drill through any surface that may contain live electrical wiring. Drilling into a live wire could cause exposed metal parts of the drill to be made live. Remove chips wrapped around Cutter and arbor after each hole. With motor off and power disconnected, grasp chips with leather gloved hand or pliers and pull while rotating counterclockwise. Should the cutter become jammed in the work, stop the unit immediately to prevent personal injury. Disconnect the drill from the power supply and loosen jammed cutter by turning the arbor counterclockwise. Never attempt to free the jammed cutter by starting the motor. Service at authorized repair center only.

25. Operating Near Welding Equipment

DO NOT operate this unit on the same work surface that welding is being performed on. Severe damage to the unit, particularly the power cord, could occur. This could also result in personal injury to the operator.

26. Circuit Breaker (If Applicable)

Changing of the circuit breaker to a higher amp rated breaker, or bypassing the circuit breaker is not recommended and will void product warranty.

27. Circuit Breaker Operation (If Applicable)

The circuit breaker is a thermal breaker. When it reaches the higher temperature rating it will trip and cause the unit to shut down. This is a protective device and can be reset after 5 to 10. To reset the breaker, press the breaker button back in. If it does not reset, let the unit cool a little longer until you can push the button in and it stays in position.

28. Safe Electrical Connection

Wet electrical connections are shock hazards. To prevent the cutting fluid from traveling along the cord and contacting the plug or power outlet, tie a drip loop as shown. Also elevate extension cords or gang box connections.

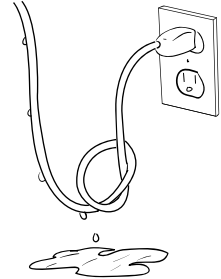

29. Save these Instructions.

SAFETY SWITCH INDICATOR LIGHT

The Safety Switch Indicator Light is a Standard Safety Feature on HMD908 magnetic drills. Its purpose is to inform the user that an unsafe condition exists.

If light is Green:

In normal operation the safety switch light will be green. Motor "On" and "Off" Switches function normally.

If light is Red:

A condition with the safety switch exists that needs to be corrected.

Possible causes:

- Safety Switch is defective. Have drill serviced.
- Uneven work surface or material. Check work surface for flatness.
- Dirt or chips under magnet. Clean work surface.

HOUGEN MANUFACTURING RECOMMENDS THAT CONDITIONS ARE CORRECTED SO LIGHT TURNS GREEN. THIS ALLOWS FOR THE UNIT TO BE OPERATED IN A SAFE MANNER.

For any questions please contact Hougén Manufacturing's Technical Service at (810) 635-7111.

OPERATION OF CONTROLS BEFORE INSTALLING HOUGEN CUTTER

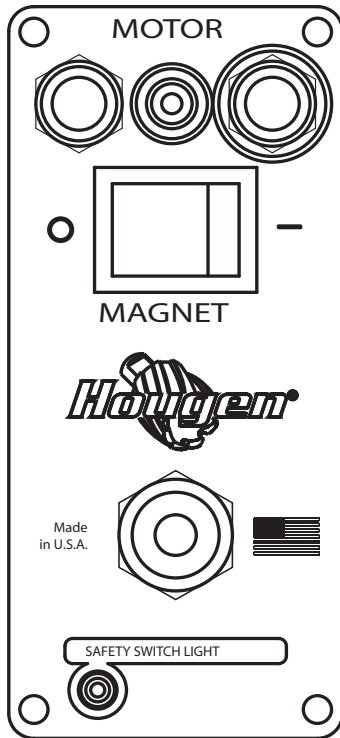

CONTROL PANEL SWITCH PLATE
FIGURE 2

IMPORTANT: Before turning on the machine, it is important that the operator understands the interrelated functions of the **SAFETY SWITCH, MAGNET SWITCH, AND MOTOR SWITCHES.**

*READ SAFETY SWITCH INDICATOR LIGHT INSTRUCTIONS
ON PREVIOUS PAGE.*

SAFETY SWITCH — Located in base of drill. Enables motor operation only when magnet is properly seated on a clean and flat work surface. Turns motor off if switch detects lift of unit.

MAGNET ON/OFF SWITCH — Energizes and De-energizes the magnetic base and activates the safety switch. Motor can now be started by pushing the motor **START** switch.

MOTOR START/STOP SWITCHES — Starts and stops the motor (See instructions previous page).

CIRCUIT BREAKER - The circuit breaker is designed to “trip” when the motor is over loaded. To reset the circuit breaker, turn off the magnet, unplug the machine and allow to cool down for approx. 5 minutes. Restart the machine by depressing the circuit breaker, plugging the machine in and continue your normal operations.

1. Place Magnetic Drill on clean, flat steel plate that is at least 9.5mm thick.
2. Plug unit into proper AC power source. **DO NOT use with DC Power.**
3. Locate the Magnet **ON** and **OFF** switch and the motor **STOP** and **START** switches (Fig. 2).
4. **NOTE: A loss of power will de-energize the magnetic base and deactivate the motor. When power is restored, the magnet will reenergize, however, the motor START switch must be depressed before the motor will start.**

OPERATING INSTRUCTIONS

Always remember that the magnet’s holding power is directly related to the workpiece thickness and surface condition. (Rating of 748 Kg pull is based on test using a 25mm thick ground surface.) Since magnetic attraction diminishes with thinner material or rough surfaces, mechanical clamping of drill unit to the workpiece should be used when cutting thin material (9.5mm or less) or material with uneven surfaces.

1. Make sure workpiece and bottom of magnet are free of chips, oil, etc.
2. Position drill by sliding it and gently feeding Arbor so that pilot point is touching center of hole to be drilled.
3. **Secure unit to workpiece with safety chain.**
4. Turn magnet ON by pressing the magnet ON switch.
5. Turn Feed Handle, raising the cutter until the pilot is above the work surface.
6. Make certain that cutter is clear of workpiece and turn motor ON by pressing the motor START switch.
7. Feed Hougen Cutter slowly into workpiece. Only after cutting path is established to a depth of about 2mm can full force be applied to feed handles.
8. Ease up on feed pressure as cutter starts breaking through.
9. At conclusion of cut, turn motor OFF by pressing motor STOP switch. Turn Feed Handles to raise Arbor thereby ejecting the slug if it hasn’t already fallen free.
10. Turn magnet OFF by pressing the magnet OFF switch.
11. **Disconnect from power source.**
12. If necessary, remove chips from cutter and magnet, preferably wearing leather work gloves and/or with pliers. Disconnect safety chain and you are ready to move unit to new drilling position.

INSTALLING HOUGEN CUTTER IN ARBOR

1. Disconnect from power source.
2. Lay drill on its side with feed handles up or be sure Arbor clears table if unit is in normal operating position.
3. Turn Feed Handles until cutter mounting set screws are exposed and completely remove the set screw.
4. Insert proper pilot in shank end of Hougen Cutter.
5. Insert Hougen Cutter until flat on cutter shank is aligned with set screw holes and is exactly perpendicular to axis of set screw holes.
6. Insert set screws and tighten. Check to be certain that cutter is secure.

ADJUSTMENT OF GIBS

1. Loosen all Gib Screws (40237).
2. Feed the drill in and out a few times and then, with top of motor slide flush with top of housing, tighten the Gib Screws until you feel them touch the Steel Gib (02431).
3. Feed the drill in and out again.
4. Adjust Gib Screws so that there is uniform pressure from top to bottom. (Top of motor slide flush with top of housing.)
5. Turn each Gib Screw in about 1/8 to 1/4 turn, depending upon your preference.
6. Gibs should be tight enough so that slide moves up and down smoothly with no wobble or shaking. (Looseness will cause cutter breakage.)

NOTE: Gibs should be lubricated regularly with general purpose grease.

ARBOR & FRONT SUPPORT BRACKET REMOVAL AND INSTALLATION

Removal

1. Loosen arbor support bracket bolts. (Remove coolant bottle on HMD908C models)
2. Loosen set screws holding arbor onto motor output shaft.
3. Remove arbor.

Installation

1. Hand tighten front support bracket bolts. Do not tighten all the way.
2. Slide arbor to full up position and hold arbor in position over hex drive motor output shaft.
3. Tighten two set screws to hold arbor onto motor output shaft.
4. Turn feed handle until motor and arbor are at the bottom of their travel.
5. Tighten front support bracket bolts to 400 in/lbs.
6. Run motor for 10 seconds. (If visual movement of arbor is noticed, restart at step 1)
7. Re-check for tightness of arbor set screws.

ARBOR ADJUSTMENT

Adjust Gibs before adjusting front support bracket.

1. Loosen Arbor Support Bracket Bolts.
2. Be sure top of arbor is flush with the shoulder on motor output shaft. Also make certain arbor is securely fastened.
3. Turn feed handle until motor and spindle are at the bottom of their travel.
4. Tighten Arbor Support Bolts.
5. Feed slide up and down a few times, checking for free and uniform movement.

NOTE: Check Arbor support bolts regularly to make certain they are tight. Tighten as required.

MAINTENANCE

In order to minimize wear on moving parts and to insure smoother operation and longer life for your magnetic drill, the following maintenance should be done periodically, based on use.

1. Regularly tighten all fasteners and replace all worn parts.
2. Check motor brushes and replace if worn. (Break in period - 30 minutes at no load speed)
3. Check power cord and cord from panel to motor and, if cracked or frayed, return to an authorized repair center for replacement.
4. Apply grease to the slide dovetails, brass gibs, and the feed gear rack. For best results use Shell Cyprina-RA or equivalent.
5. Remove arbor and pack the bearing in the front support bracket with grease. Use Shell Cyprina-RA or equivalent.

HINTS FOR SMOOTHER OPERATION

1. Keep insides of Hougén Cutter clear of chips. Chips will interfere with cutting to maximum depth, may impede the free oil flow and can cause cutter breakage.
2. Keep work, machine, arbor and Hougén Cutter free of chips and dirt.
3. Tighten all bolts and fasteners regularly.
4. We highly recommend using a light viscosity cutting fluid (preferably Hougén Cutting Fluid - Part No. 11742-4)
5. Occasionally check metering of cutting fluid flow. Lack of cutting fluid may cause Hougén Cutter to freeze in cut, slug to stick and may result in poor cutter life.
6. Always start cut with light feed pressure and then increase sufficiently to achieve maximum cutting rate.
7. Ease off on pressure as cutter begins to break through at the end of the cut.
8. Keep slide dovetails, brass gibs and feed rack lubricated and free of chips and dirt.
9. When slug hangs up in cutter, turn off motor and bring cutter down on a flat surface. This will normally straighten a cocked slug, allowing it to be ejected.
10. When cutting large diameter or deep holes it may be necessary to stop in the middle of the cut to add cutting fluid and remove the chips from around the arbor. (When doing this DO NOT raise the cutter out of the hole. Doing so can allow chips to get under the teeth of the cutter and make it difficult to restart the cut.)

#1 cause of cutter breakage and prematurely dull teeth is too little feed pressure*

* **"Babying" the cutter through the cut will only decrease tool life.**

REMEDIES FOR HOLEMaking PROBLEMS

- 1. Trouble: Magnetic base won't hold effectively to work.**
 - a. Cause: Chips or dirt under magnet.
Remedy: Clear area of chips and dirt.
 - b. Cause: Irregular surface on bottom of magnet or on workpiece.
Remedy: Lightly surface grind the bottom of the magnet flat and/or file imperfections flat on the work surface as needed.
- 2. Trouble: Cutter tends to move across surface of work.**
 - a. Cause: Magnetic base not holding effectively.
Remedy: See causes and remedies under No. 1 above.
 - b. Cause: Too much feed pressure at start of cut.
Remedy: Light pressure until a groove is cut. The groove then serves as a stabilizer.
 - c. Cause: Worn pilot.
Remedy: Replace pilot
- 3. Trouble: Out of round holes.**
 - a. Cause: Worn arbor support bracket bearing and or ejector collar.
Remedy: Replace: (only a few thousandths wear permissible.)
 - b. Cause: Misaligned support bracket
Remedy: Realign support bracket
 - c. Cause: Misaligned or loose arbor set screws.
Remedy: Tighten set screws.
- 4. Trouble: Motor and slide won't stay in set position**
 - a. Cause: Gibs too loose
Remedy: Adjust gibs
- 5. Trouble: Erratic or intermittent feed.**
 - a. Cause: Worn or pinion and/or rack.
Remedy: Replace worn parts.
- 6. Trouble: Motor doesn't run when motor START button is pushed.**
 - a. Cause: Magnet is not turned on
Remedy: Push magnet ON button.
 - b. Cause: Magnet on rough or dirty work surface and safety switch not fully depressed.
Remedy: File work surface flat and clean all chips and oil from under magnet.
 - c. Cause: No power
Remedy: Check power source and extension cords.
 - e. Cause: Worn motor brushes
Remedy: Replace brushes
 - f. Cause: Faulty motor START switch
Remedy: Return unit to an authorized repair center to have switch replaced.

NOTE: If you are unable to correct any malfunction after trying the above, do not attempt to operate the drill. Return the unit to the factory or authorized repair center for service.

INSTALLING COOLANT BOTTLE HMD908(C) MODELS

The Coolant Bottle is Attached as follows:

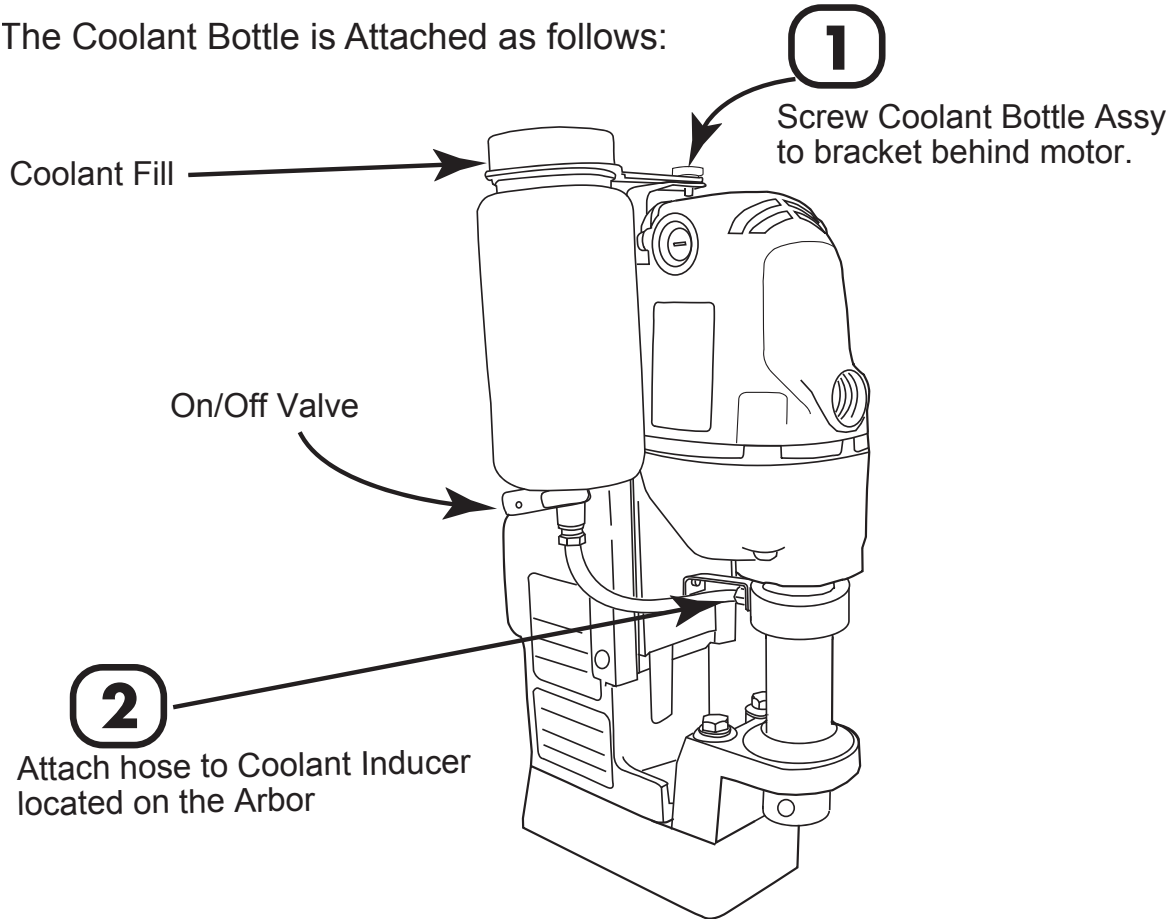

Instructions for Use:

1. Fill Coolant Bottle with properly mixed RotaMagic™ Cutting Fluid.
2. Turn On/Off Valve to "On" position.
3. Press pilot gently down on work surface. (Coolant should slowly release from bottom of cutter.)
4. Continue with drilling operation.

OPERATION OF ARBOR WITH CUTTING FLUID RESERVOIR - HMD908 MODELS

1. With Magnetic Drill in operating position, turn the feed handles so that cutter and pilot are above the work surface.
2. With magnet turned ON and motor OFF, fill reservoir by introducing cutting fluid through slots in Arbor.
Cutting fluid should not leak out.
3. Test metering capabilities of Arbor/Cutter/Pilot assembly (magnet ON-motor OFF) by feeding the Arbor gently toward work surface until pilot is pushed up into Cutter, thus allowing fluid to filter down onto work surface through groove in pilot.
4. For proper lubrication, all cutting fluid in reservoir should empty onto work surface in no less than 15 seconds and no longer than 30 seconds

SWIVEL BASE ADJUSTMENTS

Tighten Swivel Clamp Handle until snug.
(Lift up on handle and readjust if multiple
adjustments have to be made to fine
tune the handles position and tightness)

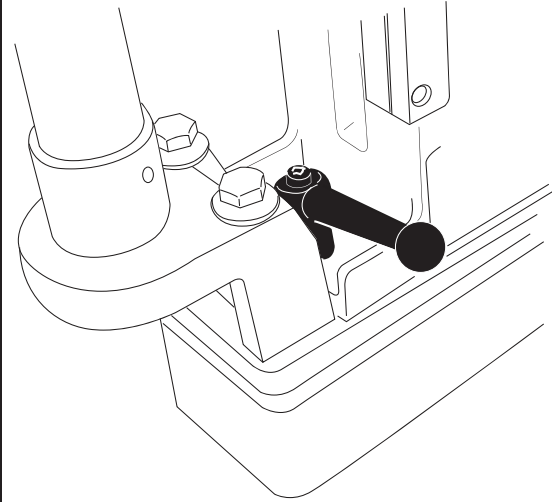
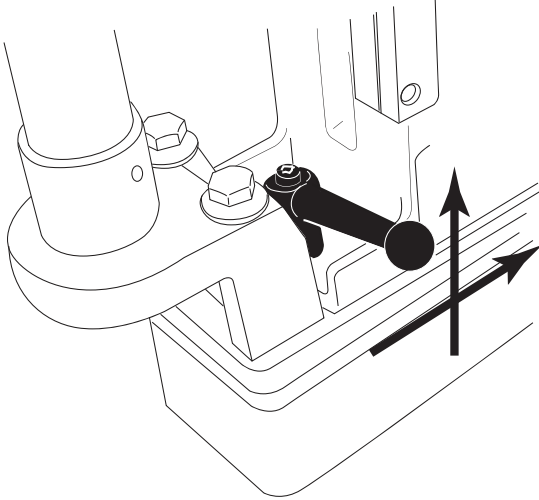

When properly adjusted the handle should lock
the swivel base when it is centered between
the Front Support Bracket and the housing.

**NOTE: CLAMP HANDLE MUST BE TIGHT PRIOR TO CUTTING HOLES -
EQUIPMENT DAMAGE OR PERSONAL INJURY COULD OCCUR**

MOTOR PARTS DIAGRAM

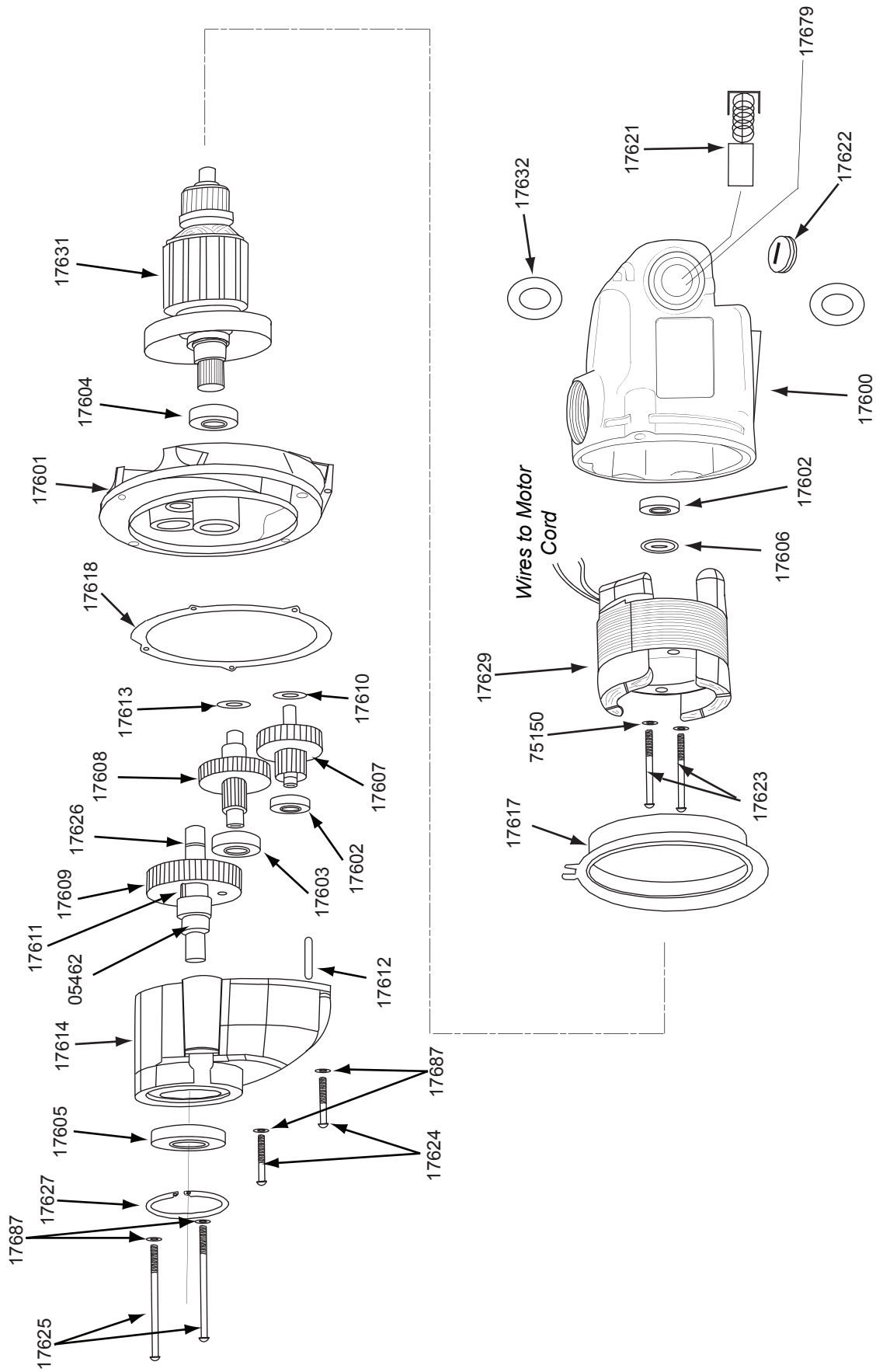

MOTOR PARTS DIAGRAM (CONT)

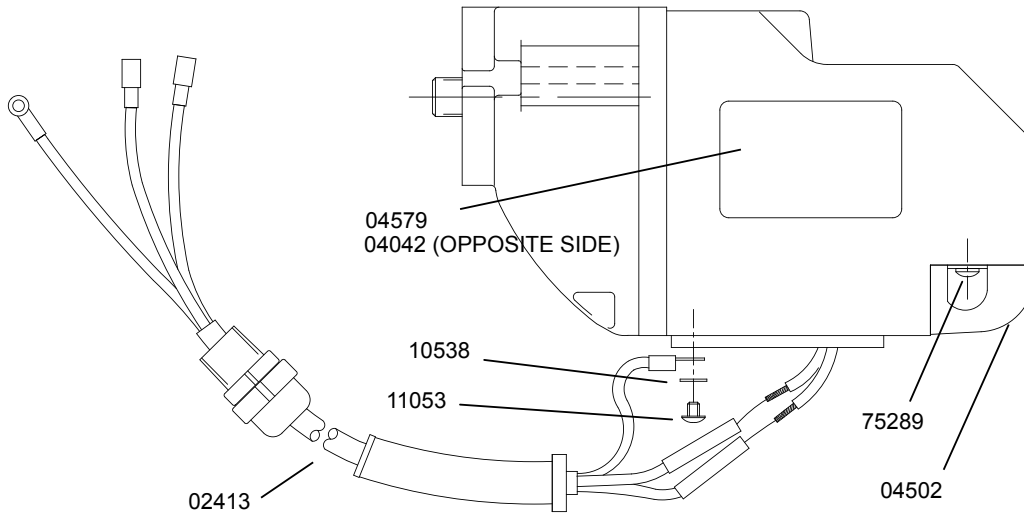

Motor Parts List

Part #	Description	Qty	Part #	Description	Qty
02413	Motor Cord	1	17613	Flat Washer	1
04502	Brush Cover	2	17614	Gear Housing	1
04042	Label, Motor Safety	1	17616	Spindle	1
04579	Label, Motor	1	17617	Fan Guide	1
05462	Spindle - Hex Drive	1	17618	Gasket	1
10538	Washer #8	1	17621	Carbon Brush (Pair)	1
11053	BHS Screw #8-32	1	17622	Brush Cap	2
17600	Field Case	1	17623	Pan Head Screw	2
17601	Gear Housing	1	17624	Pan Head Screw Short	2
17602	Ball Bearing	2	17625	Pan Head Screw Long	2
17603	Ball Bearing	1	17626	Retaining Ring	1
17604	Ball Bearing	1	17627	Retaining Ring	1
17605	Ball Bearing	1	17629	Field	1
17606	Dust Seal	1	17631	Armature	1
17607	1st Inter. Gear Assy	1	17632	Paper Washer	2
17608	2nd Inter. Gear Assy	1	17679	Brush Holder	2
17609	Spur Gear	1	17687	Lock Washer Heli M6	4
17610	Flat Washer	1	75150	Lock Washer Heli M5	2
17611	Key	1	75289	Pan Head Screw	2
17612	Dowel Pin	1			

CONTROL PANEL HOOK UP DIAGRAM

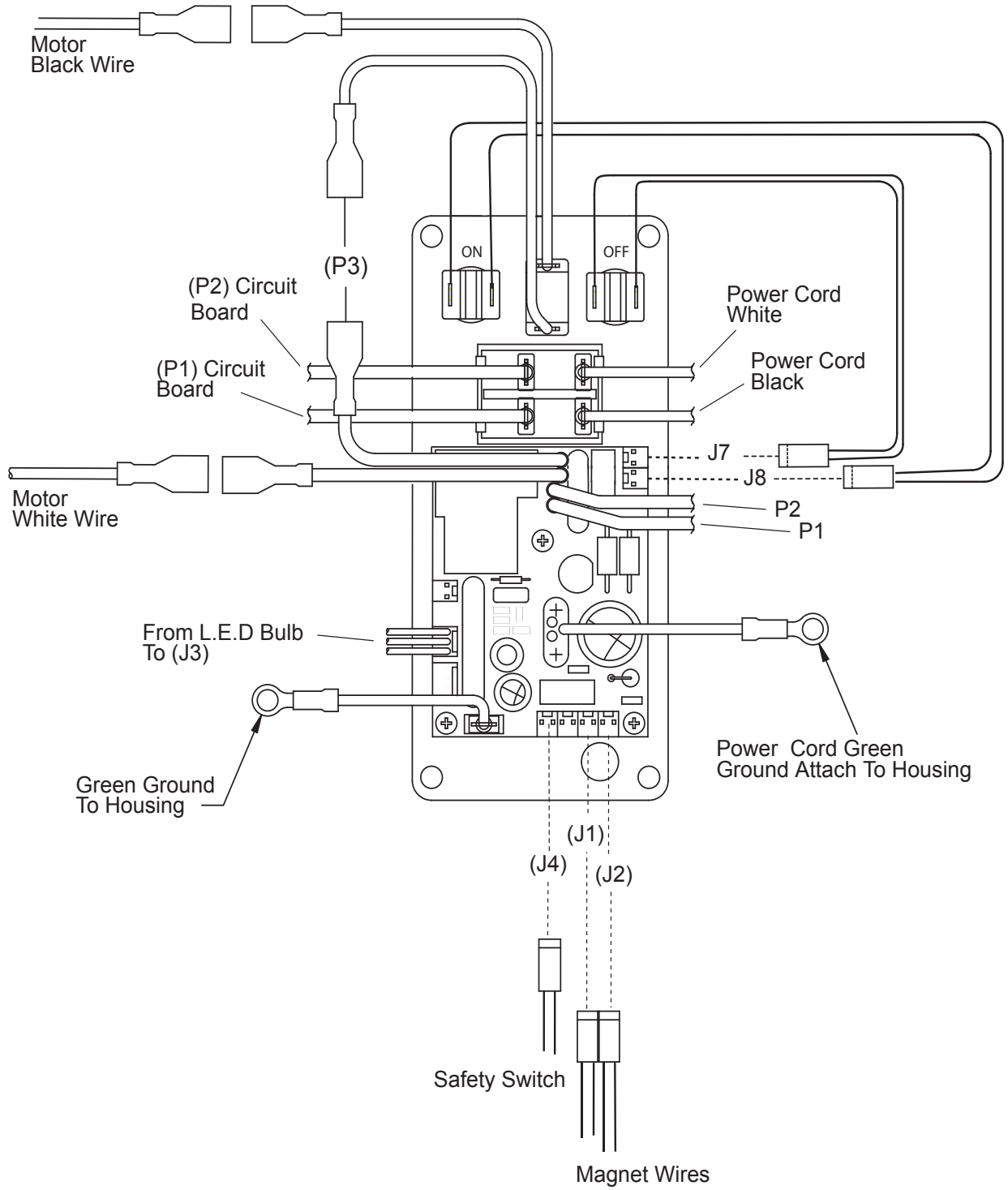

CONTROL PANEL PARTS - All Models

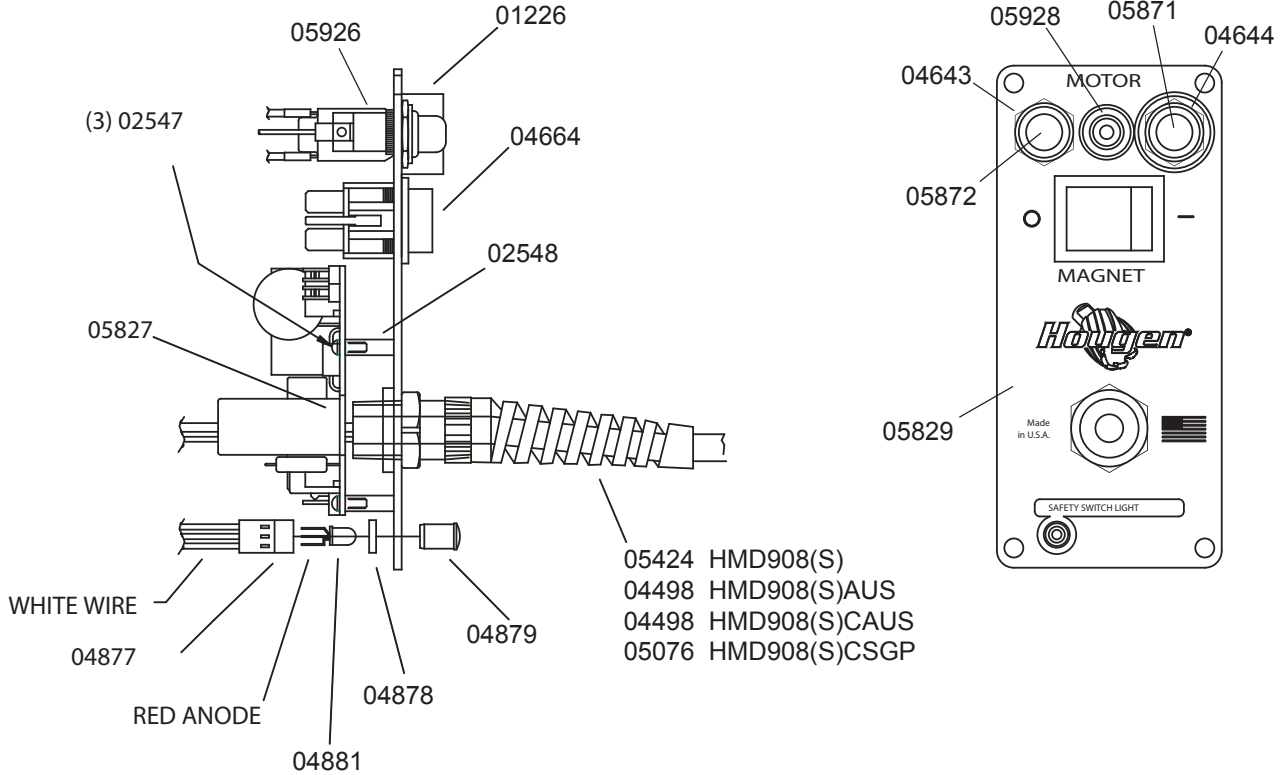

NOTE: WHEN INSERTING L.E.D. DETAIL#5 INTO
 HARNESS DETAIL#2 MAKE SURE FLAT ON BULB
 LINES UP WITH WHITE WIRE ON HARNESS.

CONTROL PANEL ASSEMBLIES COMPLETE
 HMD908(S): 05290 HMD908(S)AUS: 05946
 HMD908(S)CAUS: 05946 HMD908(S)CSGP: 05309

Part #	Description	Qty	Part #	Description	Qty
01226	Switch Guard	1	04881	L.E.D Bulb	1
02547	#4-40 x 5/16 Screw	3	05076	Power Cord (HMD908CSGP)	1
02548	Stand-off 3/16 x 9/16	3	05205	Green Wire Assy,	1
04498	Power Cord (HMD908AUS)	1	05424	Power Cord (HMD908)	1
04498	Power Cord (HMD908CAUS)	1	05827	Circuit Board	1
04643	Red Switch Cover	1	05926	Circuit Breaker	1
04644	Green Switch Cover	1	05928	Circuit Breaker Boot	1
04664	Magnet Switch	1	05929	Faceplate	1
04877	Wire Harness	1	05871	Motor ON Switch	1
04878	Spacer	1	05872	Motor OFF Switch	1
04879	Clear Lens	1	90690	Cable Tie	1

NOTES

MODEL HMD908 SERIES EXPLODED DIAGRAM

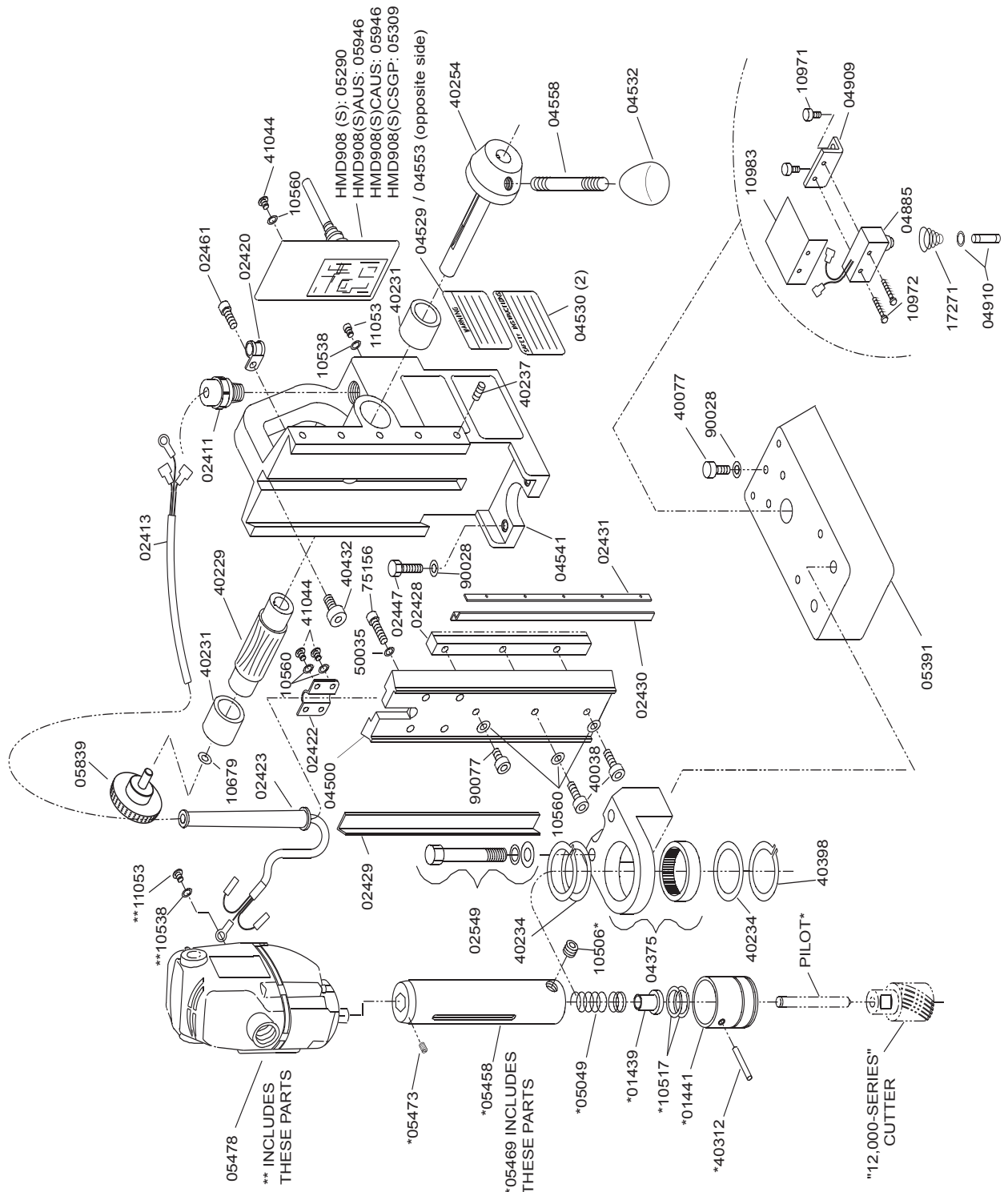

HMD908 DRILL PARTS LIST

Part #	Description	Qty	Part #	Description	Qty
01439	SHC Screw 1/4-28	1	05391	Magnet	1
01441	Ejector Collar	1	05458	Arbor Body	1
02411	Strain Relief - Motor Cord	1	05469	Arbor Assy	1
02413	Motor Cord Assy	1	05473	Set Screw #-.32 x 3/8	2
02420	Motor Cord Clamp	1	05478	230V Motor	1
02422	Motor Cord Bracket	1	05839	Knob	1
02423	Motor Cord Flex. Protector	1	10506	Set Screw 3/8-24	2
02428	Rack Gear	1	10517	Retaining Ring	2
02429	Brass Gib - Right	1	10538	Lock Washer	2
02430	Brass Gib - Left	1	10560	Lock Washer #10 Ext	11
02431	Steel Gib	1	10679	1/4 Flat washer	1
02447	Bolt-Hex Head 1/4-28	2	10971	SHC Screw 1/4-20 x 1/2	2
02461	BHC Screw 1/4-20	1	10972	BHC Screw #6-32	2
02549	3/8" Bolt Kit	1	10983	Safety Switch Shield	1
04375	Front Support Bracket	1	11053	BHC Screw #8-32	2
04500	Motor Slide Mount	1	17271	Spring	1
04529	Warning Tag	1	40038	SHC Screw #10-32	2
04530	Safety Tag	2	40077	SHC Screw 1/4-20	1
04532	Feed Handle Knob	3	40229	Feed Gear	1
04541	Housing Assy	1	40231	Bronze Bushing	2
04553	Warning Tag - Chain	1	40234	Thrust Washer	2
04558	Feed Handle	3	40237	Gib Screw	5
04885	Safety Switch Assy	1	40254	Hub Assy	1
04909	Bracket Safety Switch	1	40312	Roll Pin Altered	1
04910	Plunger Assy	1	40398	Retaining Ring	2
05049	Arbor Spring	1	40432	SHC Screw 1/4-28	1
05290	Control Panel Assy (HMD908(S))	1	41044	BHC Screw #10-32	6
05946	Control Panel Assy (HMD908(S) AUS)	1	50035	Lock Washer 1/4 Ext	4
05946	Control Panel Assy (HMD908(S)CAUS)	1	75156	SHC Screw M6 x 15mm	4
05309	Control Panel Assy (HMD908(S)CSGP)	1	90028	Lock Washer 1/4 Heli	3
			90077	BHC Screw #10-32	1

HMD908C MODELS - PARTS LIST

Part #	Description	Qty	Part #	Description	Qty
02411	Strain Relief - Motor Cord	1	05358	Washer Shim	1
02413	Motor Cord Assy	1	05391	Magnet	1
02420	Motor Cord Clamp	1	05461	Arbor Body	1
02422	Motor Cord Bracket	1	05471	Arbor Assy	1
02423	Motor Cord Flex. Protector	1	05473	Set Screw #10-32 x 3/8	2
02428	Rack Gear	1	05478	230V Motor	1
02429	Brass Gib - Right	1	05839	Knob	1
02430	Brass Gib - Left	1	10506	Set Screw 3/8-24	2
02431	Steel Gib	1	10517	Retaining Ring	1
02447	Bolt-Hex Head 1/4-28	2	10538	Lock Washer	2
02461	BHC Screw 1/4-20	1	10560	Lock Washer #10 Ext	11
02549	3/8" Bolt Kit	1	10679	1/4 Flat washer	1
02677	Handle SGP Model	1	10971	SHC Screw 1/4-20 x 1/2	2
04157	Screw FHSC #10-32	2	10972	BHC Screw #6-32	2
04375	Front Support Bracket	1	10983	Safety Switch Shield	1
04391	O-Ring for Hex Spindle	1	11053	BHC Screw #8-32	2
04500	Motor Slide Mount	1	17271	Spring	1
04529	Warning Tag	1	40038	SHC Screw #10-32	2
04530	Safety Tag	2	40077	SHC Screw 1/4-20	1
04532	Feed Handle Knob	3	40229	Feed Gear	1
04541	Housing Assy	1	40231	Bronze Bushing	2
04558	Feed Handle	3	40234	Thrust Washer	2
04885	Safety Switch Assy	1	40237	Gib Screw	5
04909	Bracket Safety Switch	1	40254	Hub Assy	1
04910	Plunger Assy	1	40295	Coolant Inducer Collar	1
04986	Rubber Washer	1	40300	O-Ring	2
05050	Compression Spring	1	40301	Washer	2
05054	Spring Seat	1	40302	Retaining Ring	2
05055	Collar	1	40303	Tube Fitting	1
05057	Bracket for Coolant Bottle	1	40332	Coolant Inducer Assy	1
05058	Bracket for Coolant Inducer	1	40398	Retaining Ring	2
05059	Holder for Coolant Bottle	1	40432	SHC Screw 1/4-28	1
05060	Coolant Bottle Assy	1	41044	BHC Screw #10-32	6
05061	Plastic Knob	1	50035	Lock Washer 1/4 Ext	4
05290	Control Panel (HMD908(S))	1	75156	SHC Screw M6 x 15mm	4
05946	Control Panel (HMD908(S)CAUS)	1	90028	Lock Washer 1/4 Heli	3
05946	Control Panel (HMD908(S)AUS)	1	90077	BHC Screw #10-32	1
05309	Control Panel (HMD908(S)CSGP)	1			

HMD908S PARTS LIST

Part #	Description	Qty	Part #	Description	Qty
01439	Spring Seat	1	05659	Clamp Handle Assembly	1
01441	Ejector Spring	1	05668	Motor Mount Slide	1
02411	Strain Relief-Motor Cord	1	05670	Retain. Ring	1
02413	Motor Cord	1	05734	Front Support Bracket	1
02420	Motor Cord Clamp	1	05736	Bolt Hex Head 3/8-24x2	2
02422	Motor Cord Bracket	1	05743	Screw-FHSC 1/4-20x3/4	4
02423	Motor Cord Flex Prot.	1	05839	Knob	1
05049	Arbor Spring	1	10506	SCR-Set 3/8-24SPL	2
05290	Control Panel (HMD908(S))	1	10517	Retain Ring	2
05946	Control Panel (HMD(S)AUS)	1	10538	Lock Washer	1
05946	Control Panel (HMD(S)CAUS)	1	10560	Lock Washer	11
05309	Control Panel (HMD(S)CSGP)	1	10679	1/4" Flat Washer	1
05458	Arbor Body	1	10971	Screw SHC 1/4-20	2
05469	Arbor Assembly	1	10972	Screw BHC #6-32	2
05628	Set Screws	1	10973	Nut	2
05669	Rack Gear	1	10977	Screw BHC 1/4-20	1
02429	Brass Gib - Right	1	10983	Safety Switch Shield	1
02430	Brass Gib - Left	1	11053	Screw BHC #8-32	1
02431	Steel Gib	1	17271	Taper Spring	1
02447	Bolt-Hex Head 1/4-28	2	40038	Screw SHC #10-32	2
02461	Screw BHC 1/4-20 x 3/8	2	40077	Screw SHC 1/4-20	1
04529	Safety Label	1	40214	Screw SHC #6-32	1
04530	Warning Label	1	40229	Feed Gear	1
04532	Feed Handle Knob	3	40231	Bronze Bushing	2
04541	Housing Assembly	1	40234	Thrust Washer	2
04553	Warning Label - Chain	1	40237	Gib Screws	5
04558	Feed Handle	3	40254	Hub Assy	1
05478	Motor Assembly (230v)	1	40312	Roll Pin	1
05392	Magnet Assembly	1	40398	Retaining Ring	1
05391	Magnet	1	40432	Screw SHC 1/4-28	1
05652	Safety Switch	1	41044	Screw BHC #10-32	6
05653	Plunger	1	50035	Lock Washer 1/4 Ext	4
05656	Swivel Plate	1	90028	Lock Washer 1/4 Heli	3
05657	Slide Plate	1	90052	Lock Washer #6 Ext	1
05658	Pivot Rod	1	90077	Screw BHC #10-32 x 1/2	1

MODEL HMD908SC SERIES EXPLODED DIAGRAM

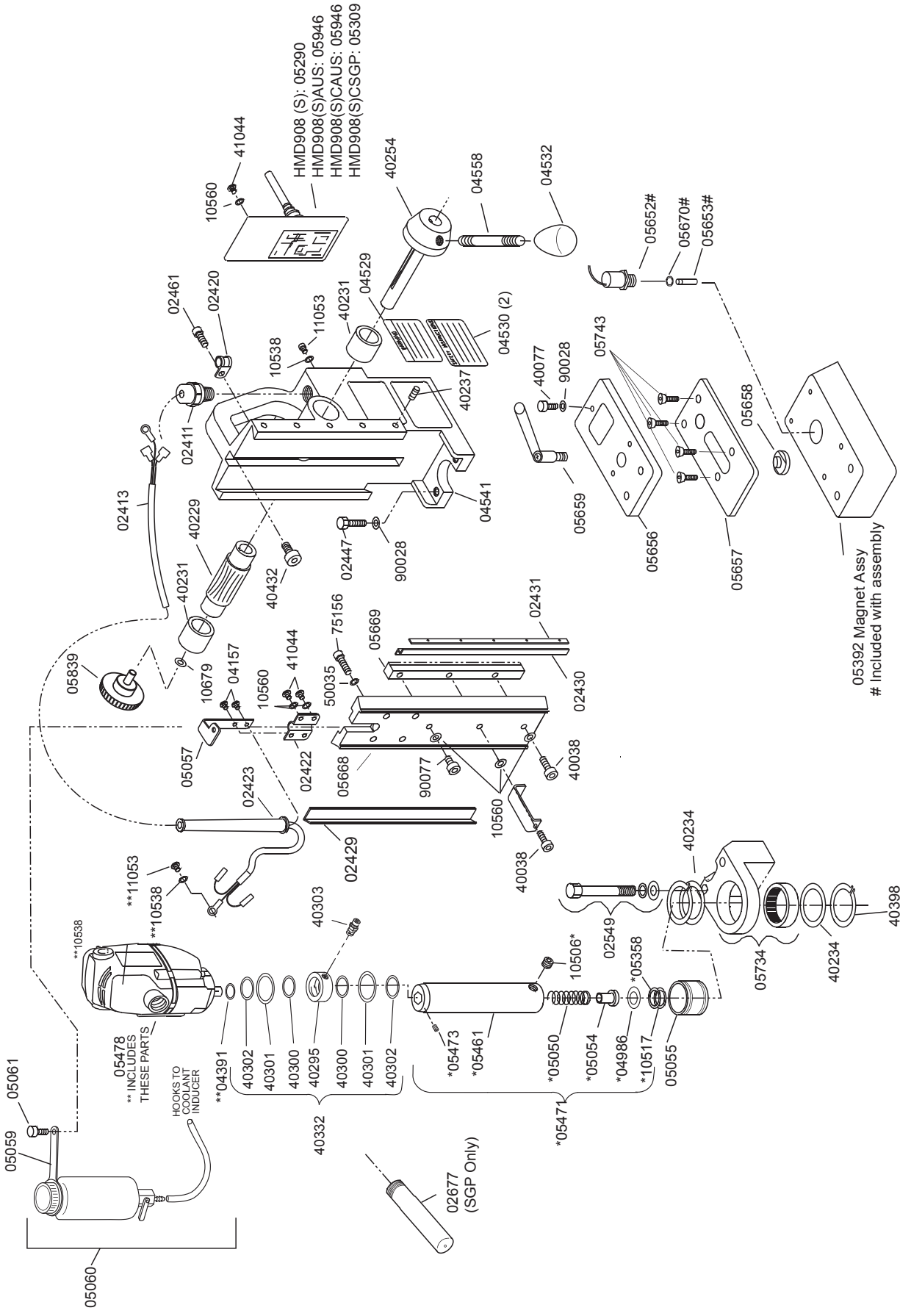

HMD908SC MODELS - PARTS LIST

Part #	Description	Qty	Part #	Description	Qty
02411	Strain Relief - Motor Cord	1	05652	Safety Switch Assembly	1
02413	Motor Cord Assy	1	05653	Plunger	1
02420	Motor Cord Clamp	1	05656	Swivel Plate	1
02422	Motor Cord Bracket	1	05657	Slide Plate	1
02423	Motor Cord Flex. Protector	1	05658	Pivot Rod	1
02429	Brass Gib - Right	1	05659	Clamp Handle	1
02430	Brass Gib - Left	1	05668	Dovetail Slide	1
02431	Steel Gib	1	05669	Rack Gear	1
02447	Bolt-Hex Head 1/4-28	2	05670	Retain Ring	1
02461	BHC Screw 1/4-20	1	05734	Front Support Bracket	1
02549	3/8" Bolt Kit	1	05743	SCR-FHSC 1/4-20 X 3/4	1
02677	Handle SGP Model	1	05839	Knob	1
04157	Screw FHSC #10-32	2	10506	Set Screw 3/8-24	2
04391	O-Ring for Hex Spindle	1	10517	Retaining Ring	1
04529	Warning Tag	1	10538	Lock Washer	2
04530	Safety Tag	2	10560	Lock Washer #10 Ext	11
04532	Feed Handle Knob	3	10679	1/4 Flat washer	1
04541	Housing Assy	1	11053	BHC Screw #8-32	2
04558	Feed Handle	3	40038	SHC Screw #10-32	2
04986	Rubber Washer	1	40077	SHC Screw 1/4-20	1
05050	Compression Spring	1	40229	Feed Gear	1
05054	Spring Seat	1	40231	Bronze Bushing	2
05055	Collar	1	40234	Thrust Washer	2
05057	Bracket for Coolant Bottle	1	40237	Gib Screw	5
05058	Bracket for Coolant Inducer		40254	Hub Assy	1
05059	Holder for Coolant Bottle	1	40295	Coolant Inducer Collar	1
05060	Coolant Bottle Assy	1	40300	O-Ring	2
05061	Plastic Knob	1	40301	Washer	2
05290	Control Panel (HMD908(S))	1	40302	Retaining Ring	2
05946	Control Panel (HMD908(S)CAUS)	1	40303	Tube Fitting	1
05946	Control Panel (HMD908(S)AUS)	1	40332	Coolant Inducer Assy	1
05309	Control Panel (HMD908(S)CSGP)	1	40398	Retaining Ring	2
05358	Washer Shim	1	40432	SHC Screw 1/4-28	1
05391	Magnet	1	41044	BHC Screw #10-32	6
05392	Magnet Assembly	1	50035	Lock Washer 1/4 Ext	4
05461	Arbor Body	1	75156	SHC Screw M6 x 15mm	4
05471	Arbor Assy	1	90028	Lock Washer 1/4 Heli	3
05473	Set Screw #10-32 x 3/8	2	90077	BHC Screw #10-32	1
05478	230V Motor	1			