



# HMD904

## PORTABLE MAGNETIC DRILL

### OPERATOR'S MANUAL



FOR USE WITH "12,000-SERIES" HOUGEN<sup>®</sup> CUTTERS

# HOUGEN®

## Portable Magnetic Drill

Model HMD904

### Welcome to Hougen

Congratulations on your purchase of the Hougen® Portable Magnetic Drill Model HMD904. Your model is designed to produce superior holes quickly and efficiently. Through constant innovation and development, Hougen is committed to provide you with hole-producing tools and products to help you be more productive.

Before attempting to operate your new Portable Magnetic Drill, please read all instructions first. These include the Operator's Manual and Warning Label on the unit itself. With proper use, care, and maintenance, your model will provide you with years of effective hole drilling performance. Once again, thank you for selecting our product and welcome to Hougen.

Photographs and Specifications shown are accurate in detail at time of printing. Manufacture reserves the right to make improvements and modifications without prior notice.

Hougen and Hougen-Edge are proprietary trademarks of Hougen Manufacturing Inc.

### **Commercial / Industrial Limited Warranty**

Hougen Manufacturing, Incorporated warrants its Portable Magnetic Drills and its Electro-hydraulic Hole Punchers for a period of 1 year and other products for ninety (90) days from date of purchase against defects due to faulty material or workmanship and will repair or replace (at its option) without charge any items returned. This warranty is void if the item has been damaged by accident or unreasonable use, neglect, improper service, or other causes not arising out of defects in material or workmanship. No other expressed warranty is given or authorized. Hougen Manufacturing, Inc. disclaims any implied warranty of MERCHANTABILITY or FITNESS for any period beyond the expressed warranty and shall not be liable for incidental or consequential damages. Some states do not allow exclusions of incidental or consequential damages or limitation on how long an implied warranty lasts and, if the law of such a state governs your purchase, the above exclusion and limitation may not apply to you. This warranty gives you specific legal rights and you may also have other rights which vary from state to state.

To obtain warranty service, return the item(s), transportation prepaid, to your nearest Factory Authorized Warranty Repair Center or to Hougen Manufacturing, Inc., 3001 Hougen Drive, Swartz Creek, Michigan 48473.

Hougen Drills are warranted against manufacturing defects only. Subject to Hougen Manufacturing inspection.

THIS WARRANTY IS IN LIEU OF ANY OTHER WARRANTY, EXPRESSED OR IMPLIED, INCLUDING ANY WARRANTY OF MERCHANTABILITY OR FITNESS FOR A PARTICULAR PURPOSE.

© 2002 Hougen Manufacturing, Inc.

# UNPACKING YOUR NEW MAGNETIC DRILL

1. Open shipping carton and remove the literature and hardware packages.
2. **Read and Follow All Instructions** before attempting to operate your new Magnetic Drill.
3. Complete and mail the Product Registration Card now. It is important that Hougen Manufacturing, Inc. have a record of product ownership.
4. Open hardware package and check contents.
  - 10565 1/8" Hex wrench for Gib Adjustment
  - 04558 Feed handles (3)
  - 04532 Feed handle knobs (3)
  - 10506 Set screw for cutter installation (2)
  - 10730 Safety chain
  - 02635 Hex wrench for cutter installation
  - 13013 5/32" Hex wrench for safety switch adjustment
5. Using the handle of Magnetic Drill, lift unit out of the shipping case.
6. Remove all packing and securing material from the drill unit.
7. Screw the three Knobs (04532) into the three Feed Handles (04558) and then screw Handles into the Hub Assembly (40254).
8. Your Magnetic Drill was factory adjusted prior to shipping. Check to make sure that all gib adjustment screws, motor mount screws, front support bracket screws, and magnet mounting screws are snug and have not vibrated loose in transit.
9. Your new Magnetic Drill comes complete with arbor mounted. The 3/4" diameter arbor bore fits all 3/4"-shank "12,000-Series" Hougen Cutters. A 1/2"-diameter bore Arbor Adapter (10851), for mounting 1/2"-shank "12,000-Series" Hougen Cutters, is optional.

**Reread Safety Warnings listed in the Operator's Manual and on the drill unit to avoid injury. Follow operating procedures.**

## IMPORTANT SAFETY INSTRUCTIONS

**WARNING:** When using electric tools, basic safety precautions should always be followed to reduce the risk of fire, electric shock, and personal injury, including the following:

### 1. Read All Instructions

### 2. Grounding Instructions

This tool should be grounded while in use to protect the operator from electric shock. The tool is equipped with a 3-conductor cord and a 3-prong grounding type lug to fit the proper grounding type receptacle. The green (or green and yellow) conductor in the cord is the grounding wire. Never connect the green (or green and yellow) wire to a live terminal. If your unit is for use on 230V, it has a plug that looks like that shown in sketch (A). If it is for use on 115V, it has a plug that looks like that shown in sketch (D). An adapter, see sketches (B) and (C), is available for connecting 115V type plugs to 2-prong receptacles. The green-colored rigid ear, lug, or the like, extending from the adapter must be connected to a permanent ground, such as a properly grounded outlet box. (See Table 2, Page 5)

### 3. Extension Cords

Use only 3-wire extension cords that have 3-prong grounding type plugs and 3-pole receptacles that accept the tool's plug. Replace or repair damaged cords. Make sure the conductor size is large enough to prevent excessive voltage drop which will cause loss of power and possible motor damage. (See Table 1)

### 4. Consider Work Area Environment

Do not expose tool to rain. Do not use tool in damp or wet locations. Keep work area well lit. Do not use tool in presence of flammable liquids or gases.

### 5. Guard Against Electric Shock

Prevent body contact with grounded surfaces. For example: pipes, radiators, ranges, refrigerator enclosures.

### 6. Safety Chains

For Operator safety -Always use the provided safety chain everytime you use the unit. Failure to use the safety chain can result in serious personal injury plus possible damage to your machine.

### 7. Keep Children Away

Do not let visitors contact tool. All visitors should be kept away from work area.

### 8. Store Idle Tools

When not in use, tools should be stored in a dry, land high or locked-up place — out of reach of children.

### 9. Use Right Tool

Do not force small tool or attachment to do the job of a heavy duty tool. Do not use tool for purpose not intended — for example — do not use a circular saw for cutting tree limbs or logs.

### 10. Secure Work

Use clamps or a vise to hold work. It is safer than using your hand and it frees both hands to operate tool.

# IMPORTANT SAFETY INSTRUCTIONS (CONT)

**11. Always Wear Safety Glasses or Goggles**

**12. Dress Properly**

Do not wear loose clothing or jewelry. They might entangle with spinning chips or get caught in moving parts. Rubber gloves and non-skid footwear are recommended when working outdoors. Wear sturdy leather gloves when working indoors. Wear protective hair covering to contain long hair.

**13. Do Not Abuse Cord**

Never carry drill unit by its cord or yank it to disconnect from receptacle. Keep cord away from heat, oil, and sharp edges.

**14. Do Not Overreach**

Keep proper footing and balance at all time.

**15. Maintain Tools With Care**

Keep tools sharp and clean for better and safer performance. Do not use dull or broken Hougén Cutters. Follow instructions for lubricating and changing accessories. Inspect tool cords periodically and, if damaged, have repaired by authorized service facility. Inspect extension cords periodically and, if damaged, have repaired by authorized service facility. Keep handles dry, clean, and free from oil and grease. Keep handles dry, clean, and free from oil and grease.

**16. Disconnect Tools**

When not in use, before servicing, and when changing Hougén Cutters or accessories.

**17. Remove Adjusting Keys and Wrenches**

Form a habit of checking to see that keys and wrenches are removed from tool before turning it on.

**18. Check Damaged Parts**

Before further use of the drill, a part that is damaged should be carefully checked to determine that it will operate properly and perform its intended function. Check for alignment of moving parts, binding of moving parts, breakage of parts, mounting, and any other conditions that may affect its operation. A part that is damaged should be properly repaired or replaced by an authorized service center unless otherwise indicated elsewhere in this operator manual. Do not operate tool if switch does not turn it on and off.

**19. Stay Alert**

Watch what you are doing. Use common sense. Do not operate tool when you are tired. Have defective switches replaced by authorized service center.

**20. Outdoor Use Extension Cords**

When tool is used outdoors, use only extension cords intended for use outdoors and so marked. Refer to **Table 1** for recommended extension cord gauge.

**21. Additional Safety Precautions**

Arbor and cutter should never be used as a hand hold. Keep hands and clothing away from all moving parts. Do not use Hougén Cutters where ejected slug might cause injury (slug ejected at end of cut). Be sure that all safety devices are properly adjusted and in use. Also, adhere to all operating instructions. Do not drill through any surface that may contain live electrical wiring. Drilling into a live wire could cause exposed metal parts of the drill to be made live. Remove chips wrapped around Hougén Cutter and arbor after each hole. With motor off and power disconnected, grasp chips with leather gloved hand or pliers and pull while rotating counter-clockwise. Should the cutter become jammed in the work, stop the unit

**22. Non-Conforming Cutting Tools**

Your Magnetic Drill is designed to use Hougén Cutters. The use of drilling tools having different shank styles is not recommended as they may not tighten securely in the drill arbor with risk of accident or injury.

**23. Operating Near Welding Equipment**

When operating your Magnetic Drill near an arc welder, it is important that they are connected to the same Earth Ground. If they are not, severe damage to the unit, particularly the power cord, could occur. This could also result in personal injury to the operator.

**24. Safe Electrical Connection**

Wet electrical connections are shock hazards. To prevent the cutting fluid from traveling along the cord and contacting the plug or power outlet, tie a drip loop as shown. Also elevate extension cords or gang box connections.

**25. Save These Instructions**

## TABLE 1

Length of Cord, Feet	Recommended Wire Gauge	Recommended Wire Gauge
	115V Motor 10-12 Amps	230V Motor 4-6 Amps
Up to 25	16	18
26-50	14	18
51-100	10	16
101-200	8	14
201-300	6	12
301-500	4	10

## TABLE 2

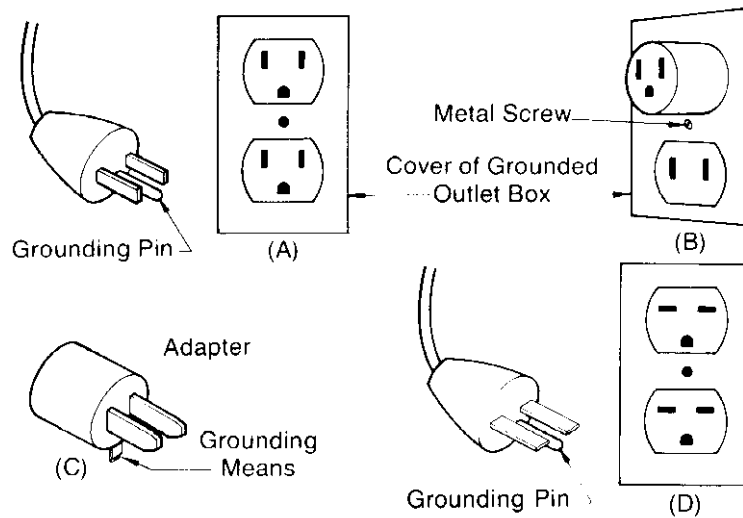

# CHECK OUT OPERATION OF CONTROLS BEFORE INSTALLING HOUGEN CUTTER

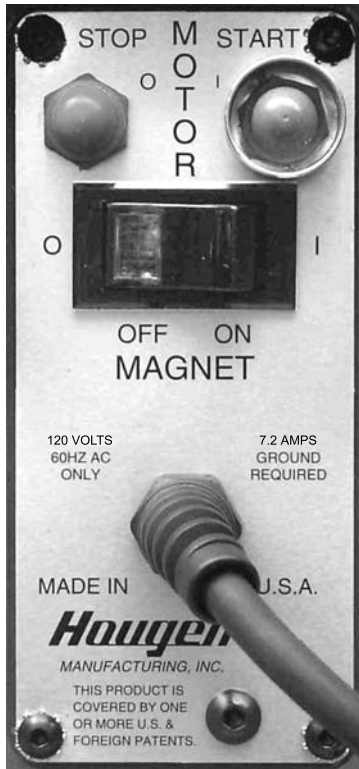

CONTROL PANEL SWITCH PLATE  
FIGURE 2

**IMPORTANT:** Before turning on the machine, it is important that the operator understands the interrelated functions of the **SAFETY SWITCH, GLIDE POST, MAGNET SWITCHES, AND MOTOR SWITCHES.**

**SAFETY SWITCH** — Located in base of drill. Enables motor operation only when magnet is properly seated on a clean and flat work surface. Turns motor off if drill unit

**MAGNET ON SWITCH** — Energizes the magnetic base and activates the safety switch. Motor can now be started by pushing the motor **START** switch.

**MAGNET OFF SWITCH** — De-energizes the magnetic base and deactivates motor **START** switch. (Note: Magnet OFF switch will not function while motor is on.)

**MOTOR START SWITCH** — Starts the motor (will not function unless the magnetic base is energized and the safety switch is activated).

**MOTOR STOP SWITCH** — Deactivates motor. Magnetic base remains energized and safety switch activated.

**GLIDE POST** — Lifts magnet and breaks residual magnetic energy after magnet is turned off. It also acts as a glide point when drill is being moved from one position to another on the work surface, thus minimizing wear on magnet. It also permits easier repositioning and protects the safety switch.

1. Place Magnetic Drill on clean, flat steel plate that is at least 3/8" thick.
2. Plug unit into proper AC power source. **DO NOT use with DC Power**
3. Locate the Magnet **ON** and **OFF** switches and the motor **STOP** and **START** switches (Fig. 2).
4. **NOTE: A loss of power will de-energize the magnetic base and deactivate the motor. When power is restored, the magnet will re-energize, however, the motor START switch must be depressed before the motor will start.**

## OPERATING INSTRUCTIONS

Always remember that the magnet's holding power is directly related to the workpiece thickness and surface condition. (Rating of 1650 pounds pull is based on test using a 1" thick ground surface.) Since magnetic attraction diminishes with thinner material or rough surfaces, mechanical clamping of drill unit to the workpiece should be used when cutting thin material (3/8" or less) or material with uneven surfaces.

1. Make sure workpiece and bottom of magnet are free of chips, oil, etc.
2. Position drill by sliding it and gently feeding Arbor so that pilot point is touching center of hole to be drilled.
3. Secure unit to workpiece with safety chain.
4. Turn magnet **ON** by pressing the magnet **ON** button.
5. Turn Feed Handle, raising the cutter until the pilot is above the work surface.
6. Make certain that cutter is clear of workpiece and turn motor **ON** by pressing the motor **START** button.
7. Feed Hougen Cutter slowly into workpiece. Only after cutting path is established to a depth of about 1/16" can full force be applied to feed handles.
8. **Ease up on feed pressure** as cutter starts breaking through.
9. At conclusion of cut, turn motor **OFF** by pressing motor **STOP** button. Turn Feed Handles to raise Arbor thereby ejecting the slug if it hasn't already fallen free.
10. Turn magnet **OFF** by pressing the magnet **OFF** button. As the magnet de-energizes, the rear of the magnet should lift up off the work surface.
11. **Disconnect from power source.**
12. If necessary, remove chips from cutter and magnet, preferably wearing leather work gloves and/or with pliers. Disconnect safety chain and you are ready to move unit to new drilling position.

# INSTALLING HOUGEN CUTTER IN ARBOR

1. Disconnect from power source.
2. Lay drill on its side with feed handles up or be sure Arbor clears table if unit is in normal operating position.
3. Turn Feed Handles until cutter mounting set screws are exposed and completely remove the set screw.
4. Insert proper pilot in shank end of Hougen Cutter.
5. Insert Hougen Cutter until flat on cutter shank is aligned with set screw holes and is exactly perpendicular to axis of set screw holes. If 1/2" diameter shank cutter is used, slip (10851) Arbor Adapter over the cutter shank with adapter hole positioned exactly over flat on cutter shank prior to inserting into Arbor bore.
6. Insert set screws and tighten. When mounting 1/2" diameter shank cutter with adapter, use longer set screw. (ordered separately) Check to be certain that cutter is secure.

## OPERATION OF CUTTING FLUID RESERVOIR

1. With Magnetic Drill in operating position, turn the feedhandles so that cutter and pilot are above the work surface.
2. With magnet turned ON and motor OFF, fill reservoir by introducing cutting fluid through slots in Arbor.  
**Cutting fluid should not leak out.**
3. Test metering capabilities of Arbor/Cutter/Pilot assembly (magnet ON-motor OFF) by feeding the Arbor gently toward work surface until pilot is pushed up into Cutter, thus allowing fluid to filter down onto work surface through groove in pilot.
4. For proper lubrication, all cutting fluid in reservoir should empty onto work surface in no less than 15 seconds and no longer than 30 seconds

## ADJUSTMENT OF GIBS

1. Loosen all Gib Screws (40237).
2. Feed the drill in and out a few times and then, with top of motor slide flush with top of housing, tighten the Gib Screws until you feel them touch the Steel Gib (02431).
3. Feed the drill in and out again.
4. Adjust Gib Screws so that there is uniform pressure from top to bottom. (Top of motor slide flush with top of housing.)
5. Turn each Gib Screw in about 1/8 to 1/4 turn, depending upon your preference.
6. Gibs should be tight enough so that slide moves up and down smoothly with no wobble or shaking. (Looseness will cause cutter breakage.)

**NOTE: Gibs should be lubricated regularly.**

## ARBOR ADJUSTMENT

**Adjust Gibs before adjusting front support bracket.**

1. Loosen Arbor Support Bracket Bolts.
3. Be sure top of arbor is flush with the shoulder on motor output shaft. Also make certain arbor is securely fastened.
4. Turn feed handle until motor and spindle are at the bottom of their travel.
5. Tighten Arbor Support Bolts.
6. Feed slide up and down a few times, checking for free and uniform movement.

**NOTE: Check Arbor support bolts regularly to make certain they are tight. Tighten as required.**

## SAFETY SWITCH ADJUSTMENT

1. Unplug unit from power source and place it on a flat sheet of steel that is at least 3/8" thick. Only magnet portion should be on steel plate. Rear support block (Glide posts should hang over the edge of the steel plate).
2. Remove Access Hole Screw (10977) from the bottom of the panel assembly.
3. Insert 5/32" Allen Wrench into access hole and back off (counterclockwise) Microswitch Adjusting Screw (10969) about three full turns.
4. Turn adjusting screw in (clockwise) about 1/8 turn at a time (removing wrench, plugging motor to power source, and turning magnet and motor ON each time) until you find exactly where motor starts.

**CAUTION — Turn switches OFF and unplug motor from power source prior to each adjustment.**

5. After determining point where motor starts, turn adjustment screw clockwise one and a half turns.
6. Plug unit to power source. Turn Magnet and Motor switches ON. Strike side of magnet at rear with rubber hammer. Motor should shut off before the magnet moves 1/2" in any direction.

**NOTE: Safety Switch adjustment should be checked regularly following the procedure outlined in Step 6 above.**

# MOTOR PARTS DIAGRAM

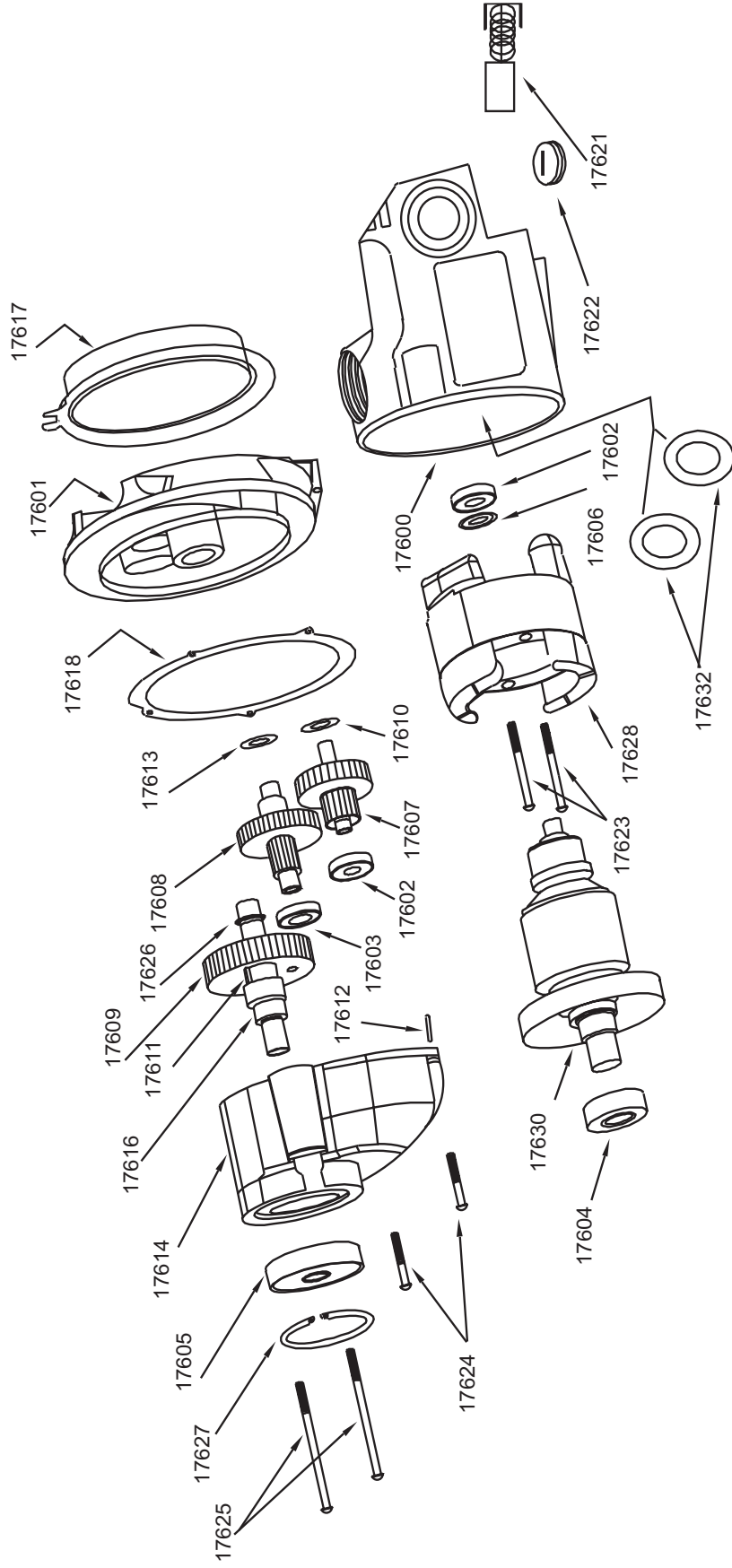



# 04503 MOTOR ASSEMBLY

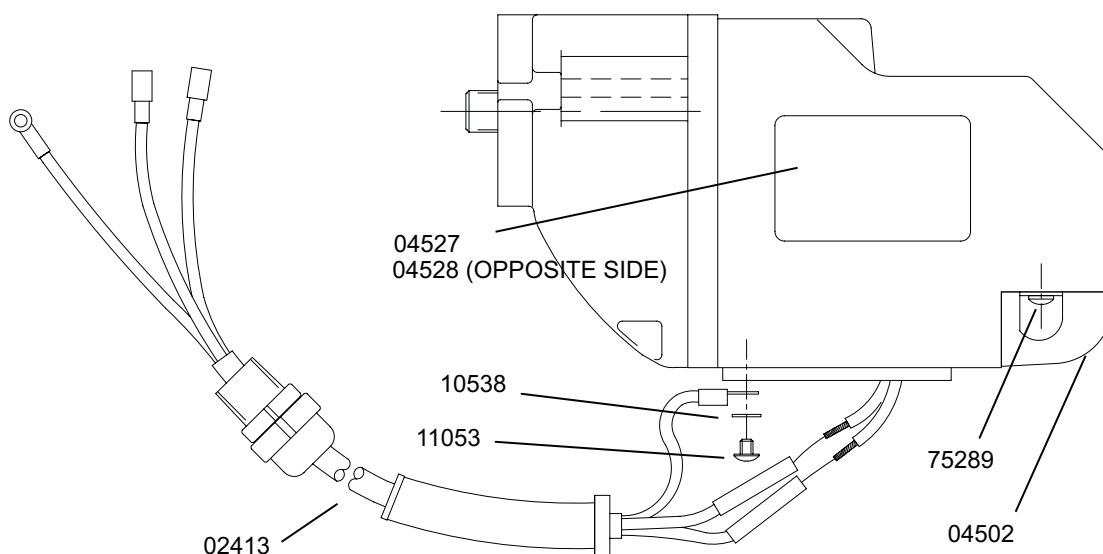

11053 BOLT TORQUE SPECIFICATIONS - TIGHTEN TO 18 IN-LBS  
 75289 BOLT TORQUE SPECIFICATIONS - TIGHTEN TO 25 IN-LBS

## MOTOR PARTS LIST

PART NO.	DESCRIPTION	QTY. REQ'D.	PART NO.	DESCRIPTION	QTY. REQ'D.
04503	MOTOR ASSY. REPLAC.		17611	KEY	1
04527	LABEL, MOTOR SPECS.	1	17612	DOWEL PIN	1
04528	LABEL, MOTOR HMD904	1	17613	FLAT WASHER	1
02413	MOTOR CORD ASSY.	1	17614	GEAR HOUSING	1
11053	SCREW, BHS #8-32	1	17616	SPINDLE	1
10538	WASHER #8 EXT.	1	17617	FAN GUIDE	1
04502	BRUSH COVER	1	17618	GASKET	1
75289	PAN HEAD SCREW	2	17630	ARMATURE	1
17600	FIELD CASE	1	17628	FIELD	1
17601	GEAR HOUSING COVER	1	17621	CARBON BRUSH	2
17602	BALL BEARING	2	17622	BRUSH CAP	2
17603	BALL BEARING	1	17623	PAN HEAD SCR.-FIELD	2
17604	BALL BEARING	1	17624	PAN HEAD SCR.-SHORT	2
17605	BALL BEARING	1	17625	PAN HEAD SCR.-LONG	2
17606	DUST SEAL	1	17626	RETAINING RING	1
17607	1ST. INTER GEAR ASSY	1	17627	RETAINING RING	1
17608	2ND. INTER GEAR ASSY	1	17632	PAPER WASHER	2
17609	SPUR GEAR	1			
17610	FLAT WASHER	1			

# CONTROL PANEL HOOK UP DIAGRAM

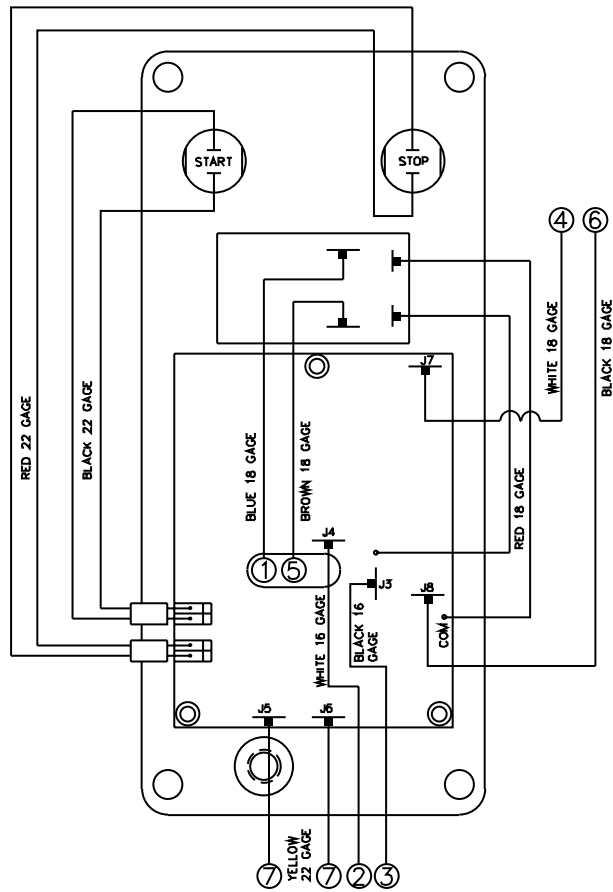

- 1 Power Cord - White
- 2 Safety Switch - White
- 3 Safety Switch - Black
- 4 Motor Cord - White
- 5 Power Cord - Black
- 6 Motor Cord - Black
- 7 Magnet Wires - Yellow

# CONTROL PANEL PARTS LIST

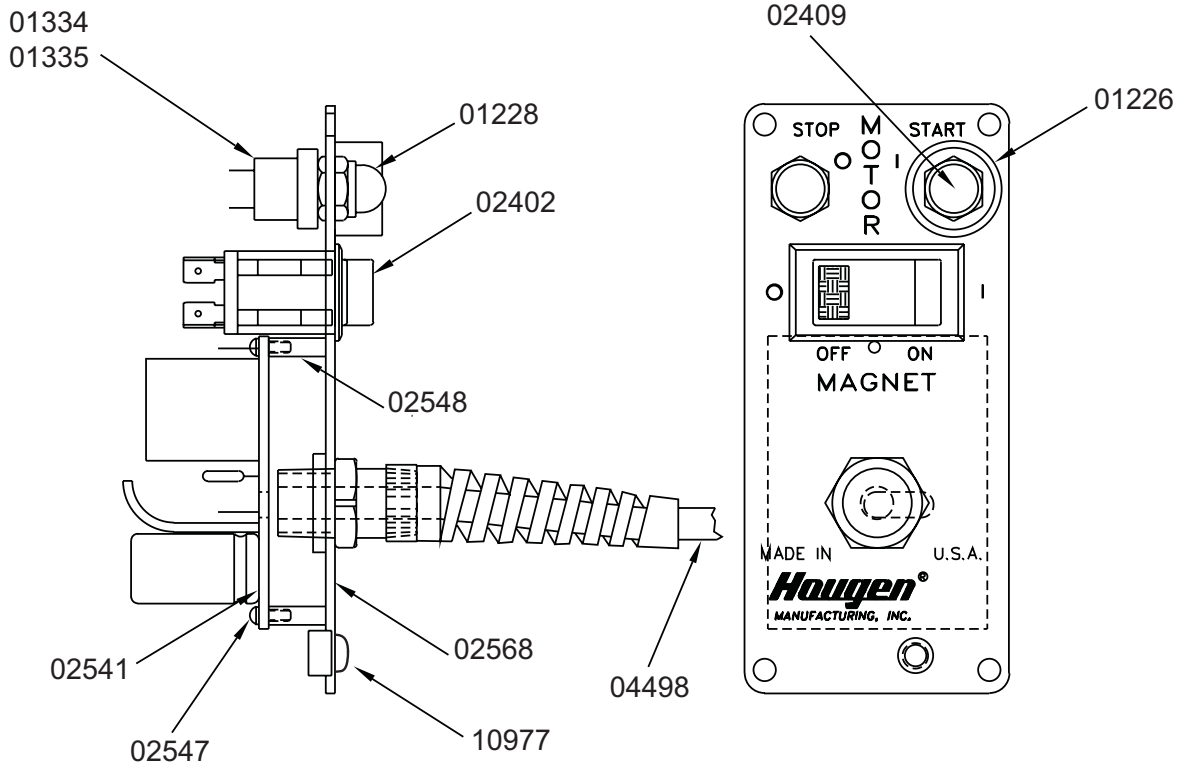

PART #	DESCRIPTION	QTY.
02568	FACEPLATE	1
02412	POWER CORD ASSY.	1
02409	SEAL SWITCH GREEN	1
01226	PUSHBUTTON GUARD	1
02402	ROCKER SWITCH	1
01228	SEAL SWITCH RED	1
01335	SWITCH ASSY. OFF/STOP	1
01334	SWITCH ASSY. ON/START	1
02541	CIRCUIT BOARD ASSY.	1
02548	SPACER	3
02547	SCREW #4-40	3
10977	SCREW, BH 1/4-20	1

# MODEL HMD904 EXPLODED DIAGRAM

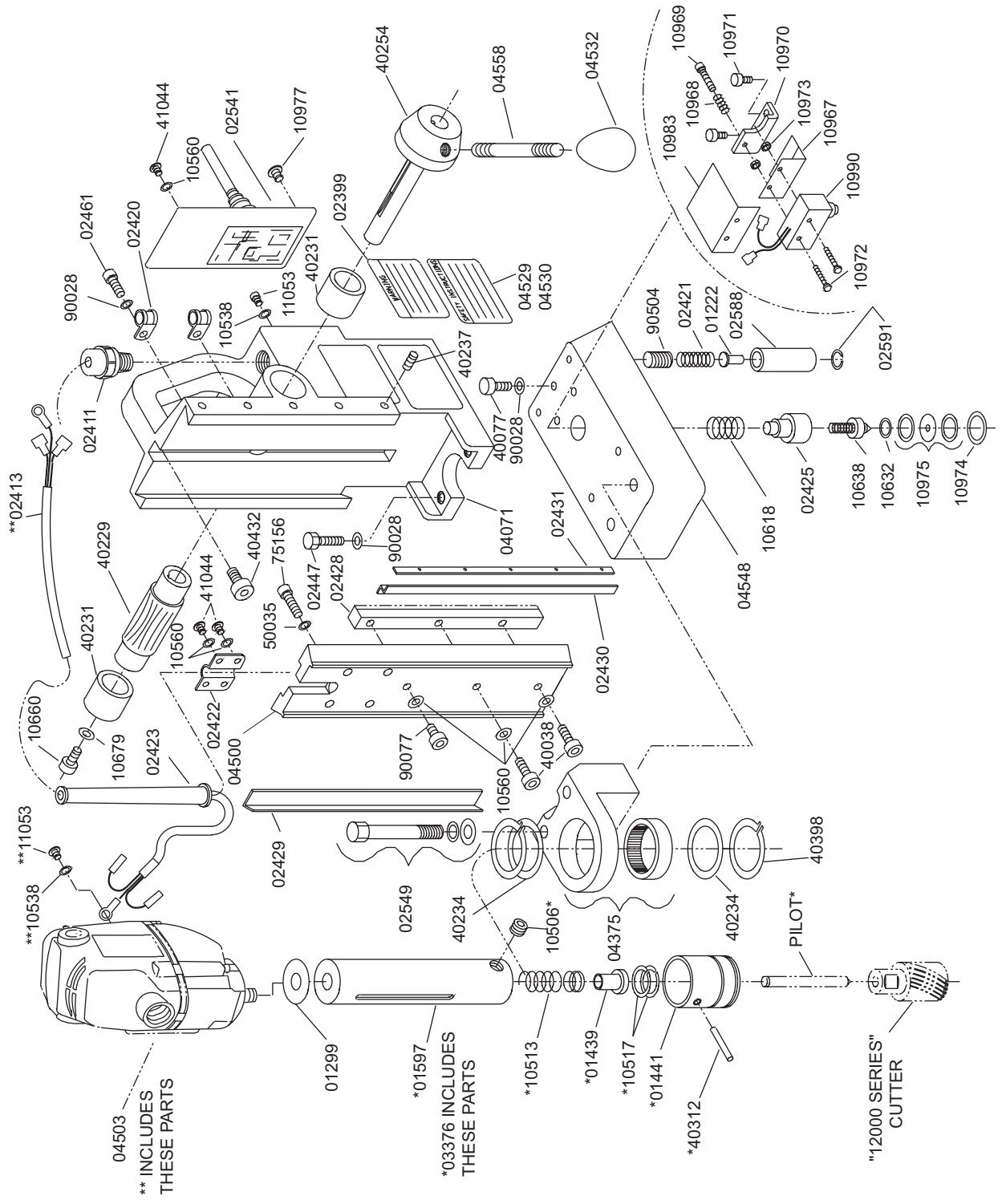

# HMD904 PARTS LIST W / ASSEMBLIES

PART NO.	DESCRIPTION	QTY. REQ'D.	PART NO.	DESCRIPTION	QTY. REQ'D.
01299	WASHER, THRUST	1	11053	SCREW, BHC #8-32	1
02411	STRAIN RELIEF - MTR. CORD	1	40038	SCREW, SHC #10-32	2
02413	MOTOR CORD ASSEMBLY	1	40077	SCREW, SHC 1/4-20	1
02420	MOTOR CORD CLAMP	2	40214	SCREW, SHC #6-32	1
02421	GLIDE POST SPRING	2	40234	THRUST WASHER	2
02422	MOTOR CORD BRACKET	1	40254	HUB ASSEMBLY	1
02423	MOTOR CORD FLEX PROTE.	1	40398	RETAINING RING	1
02425	PLUNGER BODY	1	40432	SCREW, SHC 1/4-28	1
02428	RACK GEAR	1	41044	SCREW, BHC #10-32	6
02429	BRASS GIB - RIGHT	1	50035	LOCKWASHER 1/4 EXT	4
02430	BRASS GIB - LEFT	1	90028	LOCKWASHER 1/4 HELI	5
02431	STEEL GIB	1	90052	LOCKWASHER #6 EXT.	1
02447	BOLT-HEX HEAD 1/4-28	2	90077	SCREW BHC #10-32 X 1/2	1
02461	1/4-20 X 3/8 BHC SCREW	2			
02541	CONROL PANEL ASSY.	1		<b>ASSEMBLIES</b>	
02591	RETAINING RING	2	<b>04541</b>	<b>HOUSING ASSEMBLY</b>	
03376	ARBOR ASSY	1	40231	BRONZE BUSHING	2
04375	FRONT SUPP. BRKT. ASSY.	1	40229	FEED GEAR	1
04497	CONTROL PANEL 115V	1	04529	LABEL, SAFETY	1
04500	SLIDE, MOTOR MOUNT	1	04530	LABEL, WARNING	2
04532	FEED HANDLE KNOB	3	04553	LABEL, WARNING CHAIN	1
04548	MAGNET - 115V	1	40237	GIB SCREWS	5
04558	FEED HANDLE	3	<b>03376</b>	<b>ARBOR ASSEMBLY</b>	
10538	LOCK WASHER	1	01597	ARBOR BODY	1
10560	LOCKWASHER #10 EXT.	11	01439	SEAT-SPRING	1
10618	S/S COMP. SPRING	1	10517	RETAINING RING	2
10632	RETAINING RING	1	10513	ARBOR SPRING	1
10638	SAFETY SWITCH BRG. ASSY	1	01441	EJECTOR COLLAR	1
10660	SCREW SHC 1/4-20 X 5/8	1	40312	ROLL PIN ALTERED	1
10679	1/4" FLAT WASHER	1	10506	SCR-SET 3/8-24 SPL	2
10968	S/S ADJUST SPRING	1	<b>02592</b>	<b>GLIDE POST ASSEMBLY (2)</b>	
10969	S/S ADJUST SCREW	1	02588	BODY GLIDE POST	2
10970	S/S ADJUST BRKT.	1	01222	NOSE-PLUNGER	2
10971	SCREW SHC 1/4-20	2	02421	SPRING	2
10972	SCREW BHC #6-32	2	90504	SCR-SOC SET 7/16-20	2
10973	NUT WITH NYLON	2	<b>02549</b>	<b>BOLT KIT ASSEMBLY</b>	
10974	RETAINING RING	1	02460	BOLT HEX 3/8-24 X 2 3/4	2
10975	S/S SEAL ASSEMBLY	1	40391	LOCK WASHER 3/8 HELI	2
10977	SCREW, BHC 1/4-20	1	40392	WASHER FLAT 3/8	2
10983	S/S SHIELD	1	<b>02407</b>	<b>CONTROL PANEL ASSY</b>	
10990	SAFETY SWITCH ASSY.	1	<b>04503</b>	<b>MOTOR ASSY. REPLAC.</b>	

# MAINTENANCE

In order to minimize wear on moving parts and to insure smoother operation and longer life for your magnetic drill, the following maintenance should be done periodically, based on use

1. Regularly tighten all fasteners and replace all worn parts.
2. Check motor brushes and replace if worn. (Break in period - 30 minutes at no load speed)
3. Check power cord and cord from panel to motor and, if cracked or frayed, return to an authorized repair center for replacement.
4. Apply grease to the slide dovetails, brass gibs, and the feed gear rack. For best results use Shell Cyprina-RA or equivalent.
5. Remove arbor and pack the bearing in the front support bracket with grease. Use Shell Cyprina-RA or equivalent.

## HINTS FOR SMOOTHER OPERATION

1. Keep insides of Hougén Cutter clear of chips. Chips will interfere with cutting to maximum depth, may impede the free oil flow and can cause cutter breakage.
2. Keep work, machine, arbor and Hougén Cutter free of chips and dirt.
3. Tighten all bolts and fasteners regularly.
4. We highly recommend using a light viscosity cutting fluid (preferably Hougén Cutting Fluid)
5. Occasionally check metering of cutting fluid flow. Lack of cutting fluid may cause Hougén Cutter to freeze in cut, slug to stick and may result in poor cutter life.
6. Always start cut with light feed pressure and then increase sufficiently to achieve maximum cutting rate.
7. Ease off on pressure as cutter begins to break through at the end of the cut.
8. Keep slide dovetails, brass gibs and feed rack lubricated and free of chips and dirt.
9. When slug hangs up in cutter, bring cutter down on a flat surface. This will normally straighten a cocked slug, allowing it to be ejected.
10. When cutting large diameter or deep holes it may be necessary to stop in the middle of the cut to add cutting fluid and remove the chips from around the arbor. (When doing this do not raise the cutter out of the hole. Doing so can allow chips to get under the teeth of the cutter and make it difficult to re-start the cut.

## REMEDIES FOR HOLEMaking PROBLEMS

1. **Trouble: Magnetic base won't hold effectively to work.**
  - a. Cause: Chips or dirt under magnet.  
*Remedy:* Clear area of chips and dirt.
  - b. Cause: Irregular surface on bottom of magnet or on workpiece.  
*Remedy:* Lightly surface grind the bottom of the magnet flat and/or file imperfections flat on the work surface as needed.
2. **Trouble: Cutter tends to move across surface of work.**
  - a. Cause: Magnetic base not holding effectively.  
*Remedy:* See causes and remedies under No. 1 above.
  - b. Cause: Too much feed pressure at start of cut.  
*Remedy:* Light pressure until a groove is cut. The groove then serves as a stabilizer.
  - c. Cause: Worn pilot.  
*Remedy:* Replace pilot
3. **Trouble: Out of round holes.**
  - a. Cause: Worn arbor support bracket bearing and or ejector collar.  
*Remedy:* Replace: (only a few thousandths wear permissible.)
  - b. Cause: Misaligned support bracket  
*Remedy:* Realign support bracket
4. **Trouble: Motor and slide won't stay in set position**
  - a. Cause: Gibs too loose
5. **Trouble: Erratic or intermittent feed.**
  - a. Cause: Worn or pinion and/or rack.  
*Remedy:* Replace worn parts.
6. **Trouble: Motor doesn't run when motor START button is pushed.**
  - a. Cause: Magnet is not turned on  
*Remedy:* Push magnet ON button.
  - b. Cause: Magnet on rough or dirty work surface and safety switch not fully depressed.  
*Remedy:* File work surface flat and clean all chips and oil from under magnet.
  - c. Cause: Safety switch out of adjustment  
*Remedy:* Adjust safety switch
  - d. Cause: No power  
*Remedy:* Check power source and extension cords.
  - e. Cause: Worn motor brushes  
*Remedy:* Replace brushes
  - f. Cause: Faulty motor START switch  
*Remedy:* Return unit to an authorized repair center to have switch replaced.

**NOTE: If you are unable to correct any malfunction after trying the above, do not attempt to operate the drill. Return the unit to the factory or authorized repair center for service.**

# “12,000-SERIES”

Diameter (In & mm)	Decimal Equivalent	1" - 25MM DOC PART NO.	2" - 50MM DOC PART NO.
<b>PILOTS &gt;&gt;&gt;</b>		<b>10531</b>	<b>10532</b>
7/16	.4375	12114	12214
12MM	.4724	12312	12412
<b>PILOTS &gt;&gt;</b>		<b>10533</b>	<b>10534</b>
1/2	.5000	12116	12216
9/16	.5625	12118	12218
5/8	.6250	12120	12220
11/16	.6875	12122	12222
13MM	.5118	12313	12413
14MM	.5512	12314	12414
15MM	.5906	12315	12415
16MM	.6299	12316	12416
17MM	.6693	12317	12417
18MM	.7087	12318	12418
<b>PILOTS&gt;&gt;</b>		<b>10527</b>	<b>10528</b>
19MM	.7480	12319	12419
3/4	.7500	12124	12224
20MM	.7874	12320	12420
13/16	.8125	12126	12226
21MM	.8268	12321	12421
22MM	.8661	12322	12422
7/8	.8750	12128	12228
23MM	.9055	12323	12423
15/16	.9375	12130	12230
24MM	.9449	12324	12424
25MM	.9843	12325	12425
1	1.0000	12132	12232
26MM	1.0237	12326	12426
1-1/16	1.0625	12134	12234
27MM	1.0630	12327	12427
28MM	1.1020	12328	12428
1-1/8	1.1250	12136	12236
29MM	1.1417	12329	12429
30MM	1.1812	12330	12430
1-3/16	1.1875	12138	12238
31MM	1.2205	12140	12240
1-1/4	1.2500	12140	12240
32MM	1.2598	12332	12432
33MM	1.2993	12333	12433
1-5/16	1.3125	12142	12242
34MM	1.3386	12334	12434
1-3/8	1.3750	12144	12244
35MM	1.3779	12335	12435

# HMD904 ACCESSORIES

Part No.	Description
01829	Spindle-Adapter for Jacobs Chuck
02449	Ratchet Drive
02463	Tapping Kit #6 through 1/2"
02564	Chain Mount Pipe Adapter Kit
02608	Twist Drill Adapter
03845	Twist Drill Adapter Kit Includes 5 Twist Drills with flatted shanks
05000	Portable Vac Pad
10100	1" Arbor Extender
10200	2" Arbor Extender
10732	1/2" Jacobs Chuck (Requires 01829)
12958	Counter Sink Kit
12001	Cutter Kit 1" Depth of Cut Sizes 9/16, 11/16, 13/16, 15/16, 1-1/16
12002	Cutter Kit 2" Depth of Cut Sizes 9/16, 11/16, 13/16, 15/16, 1-1/16
12003	Cutter Kit 25mm Depth Of Cut Sizes 14mm, 16mm, 18mm, 20mm, 22mm
12004	Cutter Kit 50mm Depth of Cut Sizes 14mm, 16mm, 18mm, 20mm, 22mm

