

07448 #2 MORSE TAPER ADAPTER KIT

For use on Hougen Drill Model HMD917

The 07448 Adapter Kit is to be used with drills & reamers with #2 Morse Taper Shank (not included) on a HMD917 "Slot Drive" spindle. **Maximum Diameter size is 7/8" and overall length must not exceed 10-1/4"**

- 1** Locate and remove the 1/4-28 x 1/4 Button Head Cap Screw from the Coolant Inducer with a 5/32" Hex Wrench.

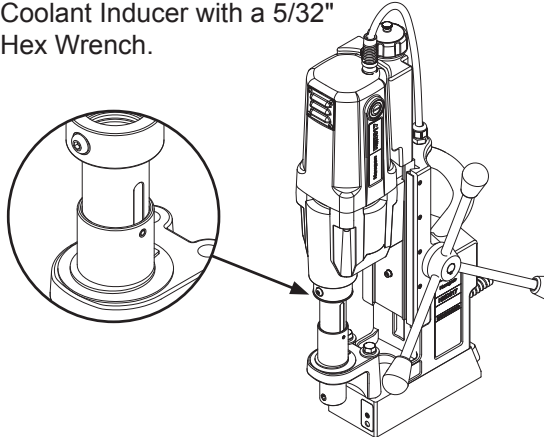

2

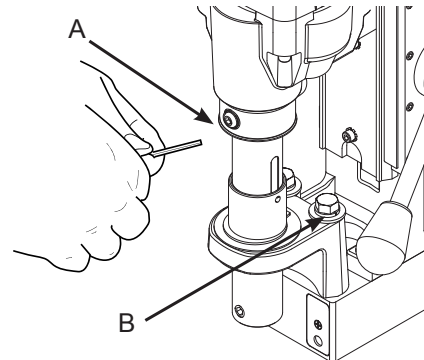

Rotate the Arbor Body so the 5/16-18 x 3/8 set screw inside, aligns with the hole in the Coolant inducer. Insert the 5/32" Hex Wrench and turn the inside set screw 1 full turn counterclock-wise or until loose.

3

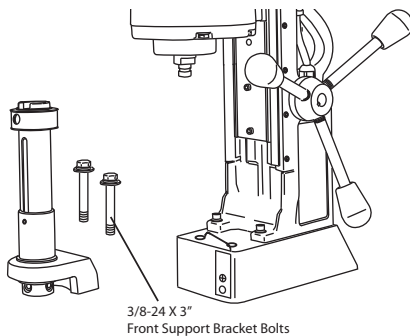

3/8-24 X 3"
Front Support Bracket Bolts

Remove both 3/8-24 x 3" Hex Bolts from the Front Support Bracket using a 9/16" wrench. Now the entire Arbor Body Assembly can be removed.

4

To install the Morse Taper, slide the Spindle Adapter (07449) up onto the Motor Spindle verifying the Spindle sits down in the slot of the Adapter. Install and tighten the 5/16-18 x 3/8 Set Screw (40256), supplied in the kit.

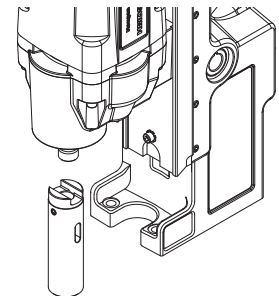

07448 SPINDLE ADAPTER KIT

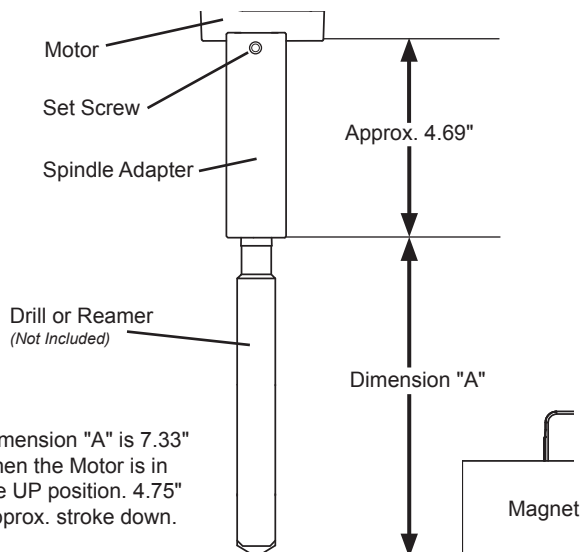

Dimension "A" is 7.33" when the Motor is in the UP position. 4.75" Approx. stroke down.



Hougen Manufacturing, Inc.
P.O. Box 2005 • Flint, MI 48501-2005
3001 Hougen Drive • Swartz Creek, MI 48473
Phone (810) 635-7111 • Fax (810) 635-8277
www.hougen.com • info@hougen.com
© 2014 Hougen Manufacturing, Inc.